

PRECISION[®] MACHINES

1" x 30" Belt & 6" Disc Variable Speed Sander

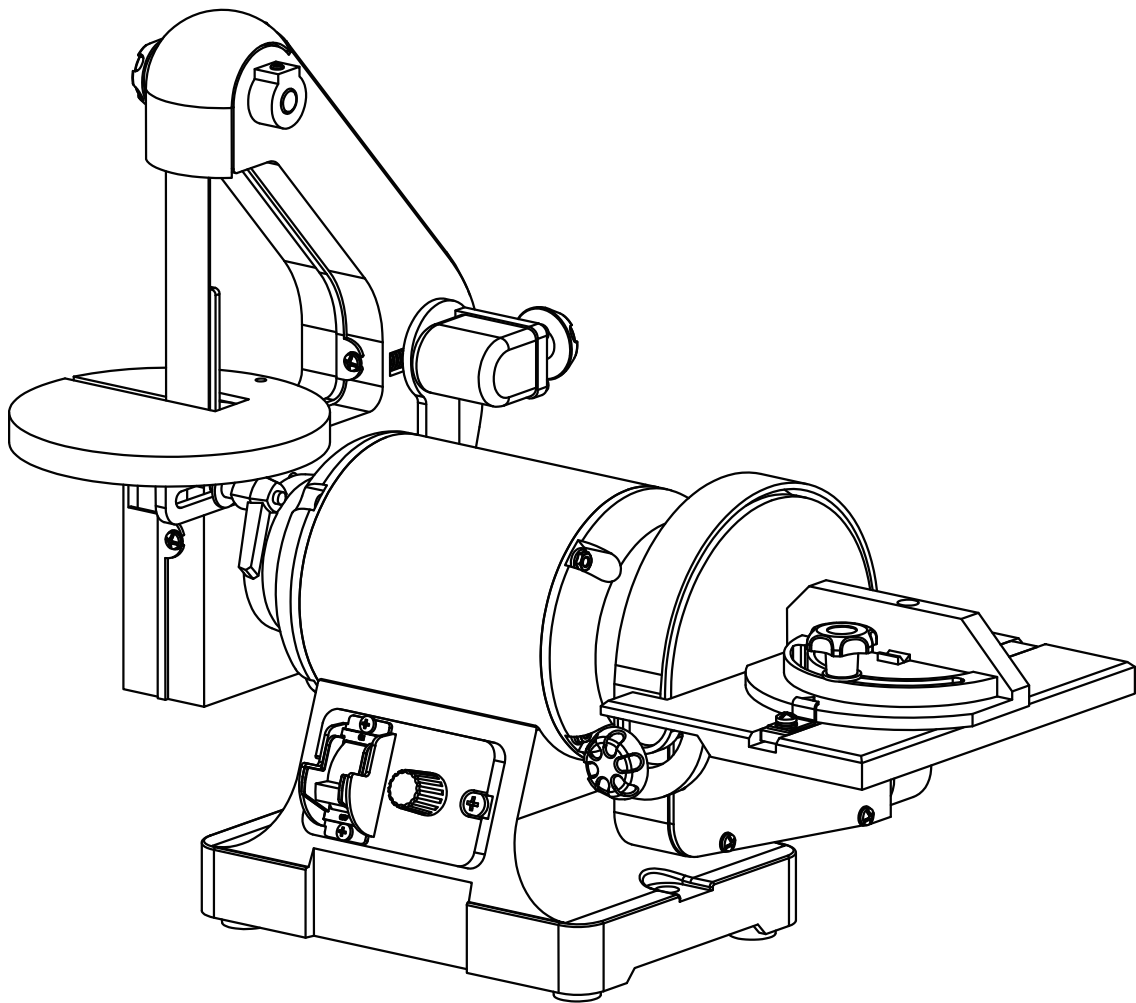

TABLE OF CONTENTS

Safety Instructions.....	3
Contents of Package	6
Getting to Know Your Sander	7
Assembly	7
Adjustments	9
General Use.....	12
Troubleshooting.....	13
Exploded View	14
Part List	15

This owner's manual is not a teaching aid and is intended to show assembly, adjustments, and general use.

SAFETY SYMBOLS

IMPORTANT! Safety is the single most important consideration in the operation of this equipment. **The following instructions must be followed at all times.** Failure to follow all instructions listed below may result in electric shock, fire, and/or serious personal injury.

There are certain applications for which this tool was designed. We strongly recommend that this tool not be modified and/or used for any other application other than that for which it was designed. If you have any questions about its application, do not use the tool until you have contacted us and we have advised you.

SAFETY SYMBOLS



SAFETY ALERT SYMBOL: Indicates DANGER, WARNING, or CAUTION. This symbol may be used in conjunction with other symbols or pictographs.



Indicates an imminently hazardous situation, which, if not avoided, could result in death or serious injury.



Indicates a potentially hazardous situation, which, if not avoided, could result in death or serious injury.



Indicates a potentially hazardous situation, which, if not avoided, could result in minor or moderate injury.

NOTICE: Shown without Safety Alert Symbol indicates a situation that may result in property damage.

GENERAL SAFETY

KNOW YOUR POWER TOOL. Read the owner's manual carefully. Learn the tool's applications, work capabilities, and its specific potential hazards.

BEFORE USING YOUR MACHINE

To avoid serious injury and damage to the tool, read and follow all of the Safety and Operating Instructions before operating the machine.

1. **ALWAYS** learn the machines applications, limitations and the specific potential hazards. Read and become familiar with the entire operating manual.
2. **ALWAYS** use a face or dust mask if the operation is particularly dusty.
3. **ALWAYS** check for damage before using the machine, check for alignment of moving parts, breakage of parts, and any other condition that may affect the machines operation. Damage should be properly repaired or the part replaced. If in doubt, DO NOT use the machine. Consult your local dealer.
4. **ALWAYS** disconnect the machine from the power supply before servicing and when changing accessories.
5. **ALWAYS** wear safety goggles, manufactured to the latest European Safety Standards. Everyday eyeglasses do not have impact resistant lenses, and are not safety glasses.
6. **ALWAYS** keep work area clean. Cluttered areas and benches invite accidents.
7. **ALWAYS** ensure that adequate lighting is available. Ensure that lighting is placed so that you will not be working in your own shadow.
8. **ALWAYS** keep children away. All visitors should be kept a safe distance from the work area, especially when the machine is being used.
9. **ALWAYS** maintain machine in top condition. Keep tools/machines clean for the best and safest performance. Follow maintenance instructions.
10. **ALWAYS** handle with extreme care and do not carry the tool/machine by its electric cable, or pull on the cable to disconnect it from the power supply.
11. **ALWAYS** ensure the switch is off before plugging in to mains. Avoid accidental starting.
12. **ALWAYS** concentrate on the job in hand, no matter how trivial it may seem. Be aware that accidents are caused by carelessness due to familiarity.
13. **ALWAYS** keep your proper footing and balance at all times - don't overreach. For best footing, wear rubber soled footwear. Keep floor clear of oil, scrap wood, etc.

SAFETY INSTRUCTIONS

14. **ALWAYS** dress properly. Loose clothing or jewellery may get caught in moving parts. Wear protective hair covering to contain long hair.
15. **ALWAYS** guard against electric shock. Avoid contact with earthed surfaces - pipes, radiators etc.
16. **NEVER** operate machine while under the influence of drugs, alcohol or any medication.
17. **NEVER** leave machine running unattended. Turn power off. Do not leave the machine until it comes to a complete stop.
18. **NEVER** force the machine, it will do a better and safer job at the rate for which it was designed.
19. **NEVER** use power tools in damp or wet locations or expose them to rain. Do not use in an explosive atmosphere (around paint, flammable liquids etc.). Avoid dangerous environments.
19. If the tool begins to make an abnormal noise, or produce excessive vibrations, smoke or burning odour, turn the tool off immediately and do not operate, until repaired.

SAFETY INSTRUCTIONS

SPECIFIC SAFETY INSTRUCTIONS FOR SANDERS

This machine is intended for the surfacing of natural, solid woods and composite materials. Any other use not as specified, including modification of the machine or use of parts not tested and approved by the equipment manufacturer can cause unforeseen damage, and invalidate the warranty.

ATTENTION: Use of this sander still presents risks that cannot be eliminated by the manufacturer. Therefore, the user must be aware that wood working machines are dangerous if not used with care and all safety precautions are adhered to.

1. ALWAYS wear ear protectors/defenders when using this machine.
2. ALWAYS wear a dust mask when using this machine. Be aware that harmful or toxic dusts could be produced when sanding some woods.
3. ALWAYS use the table to support the workpiece.
4. ALWAYS check to ensure the table and attachments are secure before starting.
5. ALWAYS maintain a clearance of 2-3mm between table and sanding disc.
6. ALWAYS hold the workpiece firmly so that it cannot be torn from your hands.
7. ALWAYS feed the workpiece against the direction of rotation of the disc. i.e the LEFT side of the disc.
8. ALWAYS keep the mains cable well away from the machine and ensure an adequate electrical supply is close at hand so that the operation is not restricted by the length of the cable.
9. ALWAYS use a dust extraction device, properly connected to the dust extraction port.
10. ALWAYS ensure that nails or foreign objects have been removed from a workpiece beforehand. Nails etc. will destroy the belt or disc.
11. NEVER allow the ventilation slots in the motor to become blocked.
12. NEVER sand pieces which cannot be held firmly by hand.

SAVE THESE INSTRUCTIONS. Refer to them often.

This owner's manual is not a teaching aid and is intended to show assembly, adjustments, and general use.

CONTENTS OF PACKAGE

UNPACKING AND CLEAN-UP

1. Carefully remove all contents from the shipping carton. Compare the contents with the list of contents to make sure that all of the items are accounted for, before discarding any packing material. Place parts on a protected surface for easy identification and assembly. DO NOT turn your machine ON if any of these items are missing. You may cause injury to yourself or damage to the machine.
2. Report any shipping damage to your local distributor. Take photographs for any possible insurance claims.
3. Clean all rust protected surfaces with ordinary house hold type grease or spot remover. Do not use; gasoline, paint thinner, mineral spirits, etc. These may damage painted surfaces.
4. Apply a coat of paste wax to the table to prevent rust. Wipe all parts thoroughly with a clean dry cloth.
5. Set packing material and shipping carton aside. Do not discard until the machine has been set up and is running properly.

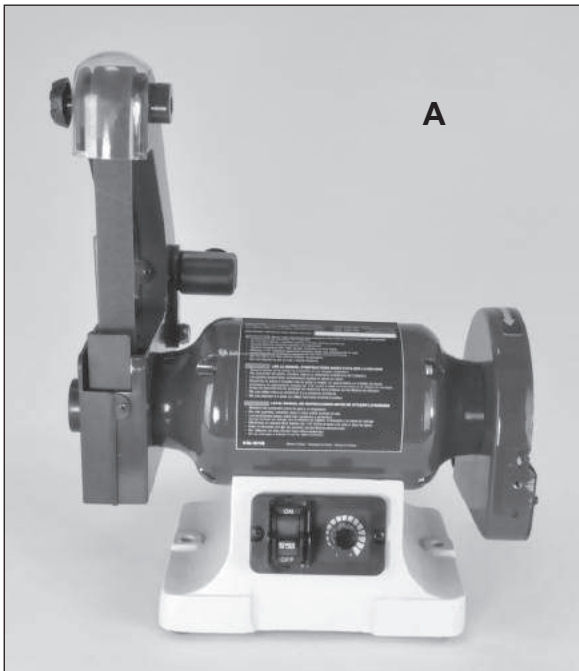
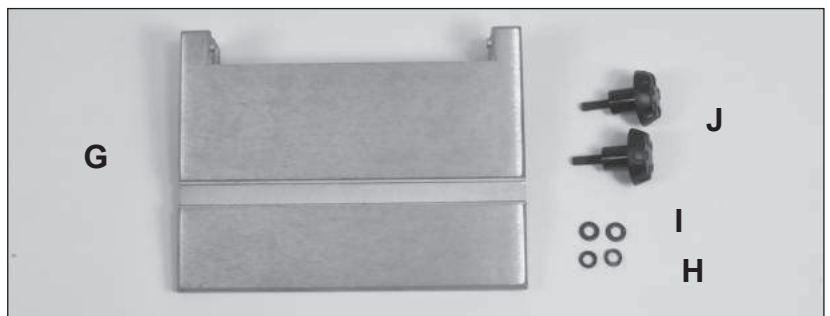
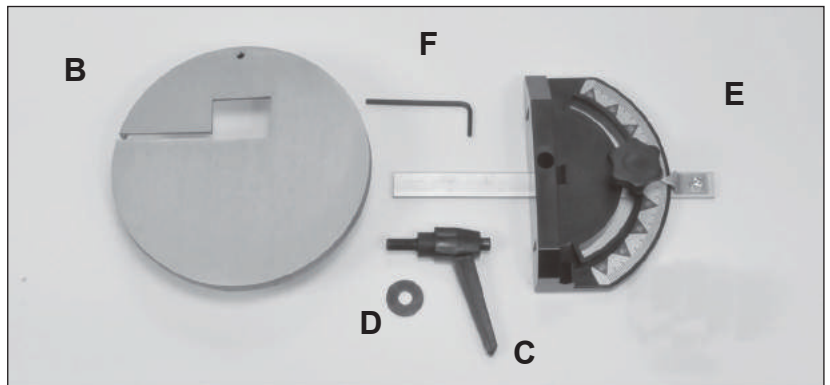

TABLE OF LOOSE PARTS



- A. Belt & Disc Sander Assembly
- B. Sanding Belt Table
- C. Lever Handle for Sanding Belt Table
- D. Washer 8mm
- E. Miter Gauge

- F. Hex Wrench 3mm
- G. Sanding Disc Table
- H. Spring Washers 6mm (2)
- I. Washers 6mm (2)
- J. Locking Handles for Sanding Disc Table (2)
- K. Manual & Warranty Card (not shown)

GETTING TO KNOW YOUR SANDER

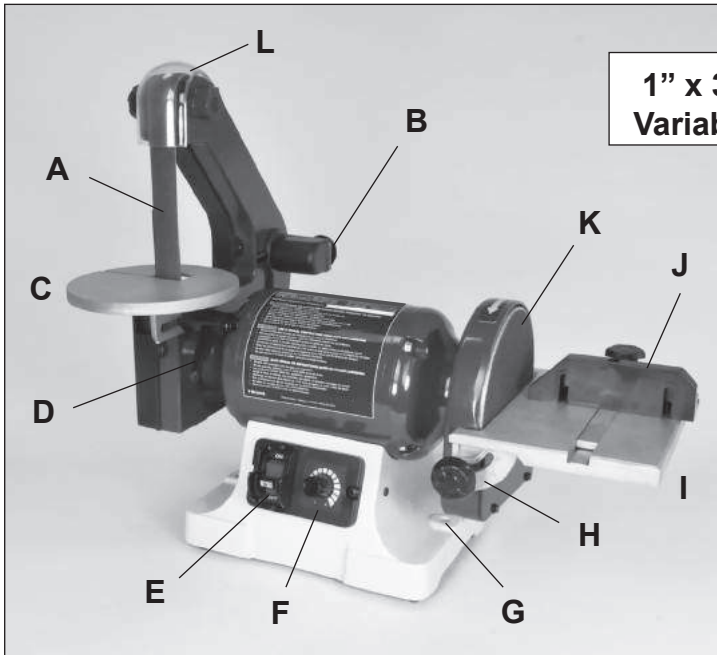

**1" x 30" Belt / 6" Disc
Variable Speed Sander**

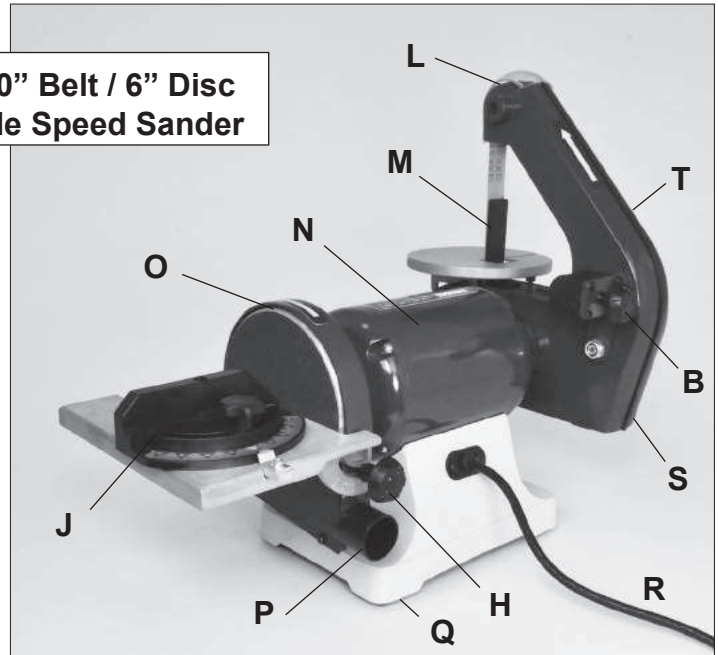

- A. Sanding Belt 1" x 30"
- B. Sanding Belt Tracking Knob
- C. Sanding Belt Table
- D. Sanding Belt Table Lock Handle
- E. ON/OFF Safety Switch
- F. Speed Control Switch
- G. Mounting Hole in Base
- H. Disc Table Angle Scale & Lock Knob
- I. Sanding Disc Table
- J. Miter Gauge

- K. Sanding Disc 6"
- L. Sanding Belt Safety Cover
- M. Platen for Sanding Belt
- N. Motor
- O. Sanding Disc Aluminum Disc
- P. Sanding Disc Guard & Dust Port
- Q. Rubber Machine Feet (4)
- H. Power Cord
- R. Sanding Belt Dust Port (not shown)
- S. Sanding Belt Guard
- T. Sanding Belt Guard

INSTALLATION

MOVING & INSTALLING THE SANDER

CAUTION When moving the sander, lift the machine with your hands positioned under the motor ends or belt and disc housings. DO NOT carry or move it using the attached work tables.

1. The machine should be firmly bolted to a stand or solid, level workbench to avoid any movement of the machine during use. The sander's base has holes for this purpose (mounting hardware is not included).

For portability and secure clamping of the sander to a workbench, the machine can be first permanently

bolted to a piece of plywood. Then the sander can be positioned on your workbench, or other solid surface, and the plywood can be clamped in place to secure the sander for use. After use, the plywood can be unclamped and the sander stored for future use.

2. When positioning the machine for work, locate it in an area that has ample space around the sander for the moving of projects to be sanded. Align the machine so that it will not face aisles, doorways, or other work areas that bystanders may be in. Do not locate or use the machine in damp or wet conditions. Use a Dust Collector to capture the fine dust that is created when sanding. See the safety instructions.

ASSEMBLY

Tools Required for Assembly:

- Hex Wrench 3mm
- #2 Phillips Screwdriver (not supplied)

ASSEMBLY

⚠ WARNING THE MACHINE MUST NOT BE PLUGGED IN AND THE POWER SWITCH MUST BE IN THE OFF POSITION UNTIL FULL ASSEMBLY AND ALL ADJUSTMENTS ARE COMPLETE.

MOUNTING THE SANDER TO A WORKBENCH

CAUTION: If during operation there is any tendency for the sander to tip over, slide or walk on the supporting surface, the sander should be properly mounted to a workbench or stand, and at a suitable, safe height for your sanding work to be carried out.

1. Rubber feet are fastened to this sander prior to shipping. They may, or may not, be used when attaching the sander to a bench or stand.
2. Position the sander on the workbench.
3. Mark the workbench through the two mounting holes located in the left and right sides of the sander base (between the holes for rubber feet).
4. Drill holes in the workbench at the 2 marks.
5. Using long bolts, washers, lock-washers and nuts; or lag bolts; (fasteners not supplied), secure the sander to the workbench. FIG. A.

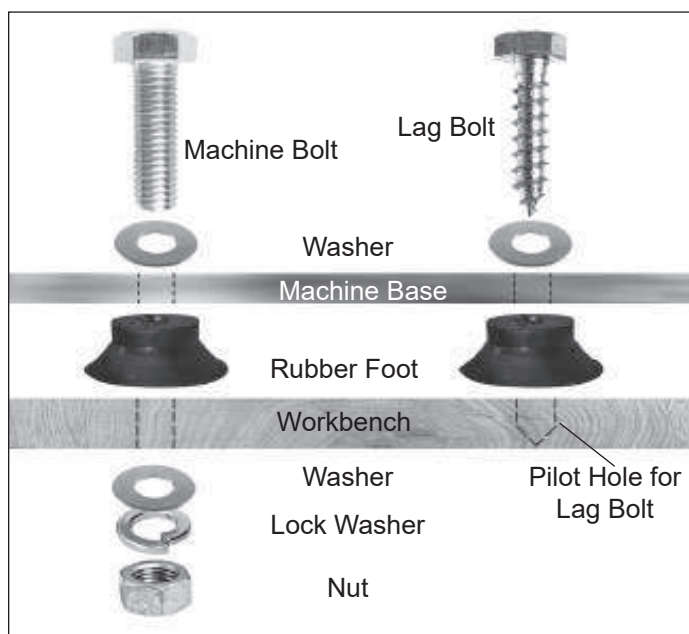

FIG. A

DUST CHUTE INSTALLATION – DISC SANDER

1. If not already pre-assembled by the factory, fasten the sanding disc dust chute and cover (Part #36) to the machine using the four Phillips M4 screws and washers (#37). FIG. B.

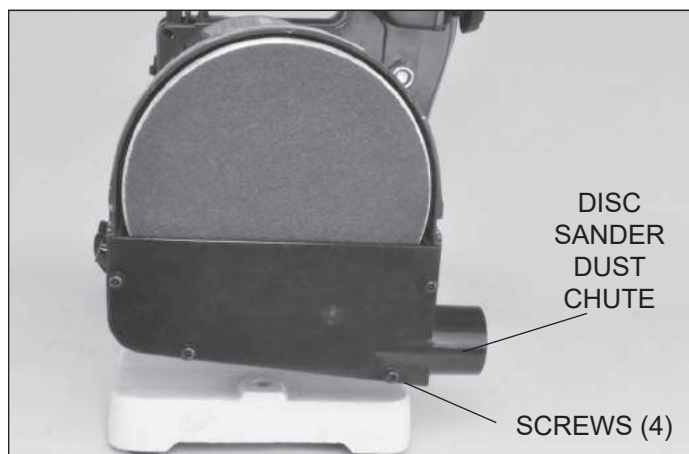

FIG. B

ASSEMBLING THE BELT SANDER TABLE

⚠ WARNING: When assembling the belt & disc sander, ensure the machine is disconnected from any power source.

1. Locate the round shaped belt-sanding table (#62).
2. Position the table by threading the belt and plate through the table's slot and square opening.
3. Fasten the table to the frame by using the table-adjustment knob and 8mm washer (#63, 64). FIG. C.
4. Bring the adjustment knob's screw through the slot in the bracket opening on the underside of the table, then into the threaded hole in the frame that houses the hex nut (#58).
5. Fasten the table in place by using the adjustment handle to turn its integral screw into the nut.

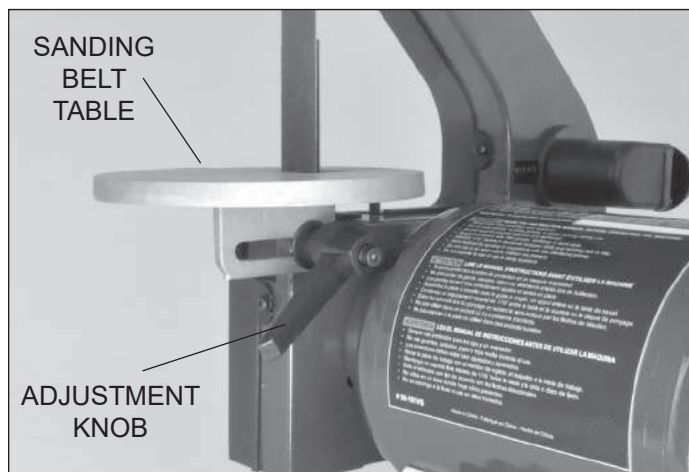

FIG. C

ASSEMBLY & ADJUSTMENTS

ASSEMBLING THE SANDING DISC TABLE

1. Attach the disc-sanding table (#38) to the sanding disc guard (#16) by tipping the table up, and slide the two small nipples extending from the rectangular mouth of the table, onto the 2 'L' mounting slots in the sides of the disc sander guide's frame. FIG. D.
2. Align the two screw holes in the guard with the arched slots above the angle gauges, so that the knobs & washers (#39, 95, 94) will travel through the angle-gauge openings on either side of the disc and into the mounting holes on the disc sander.
3. Using the disc-table adjustment handles, fasten the table to the sander.
4. When required for sanding small parts or for sanding to specific angles, use the miter gauge which slides in the slot that is in the disc-sanding table.

BELT TABLE ADJUSTMENTS

For most sanding operations, the table will likely remain at a 90° angle to the belt. A positive stop is provided with your sander to ensure fast positioning of the table at 90 degrees to the belt. To ensure and check the positive-stop 90° angle, proceed as follows:

1. Loosen the table-locking lever / knob (#63).
2. Tilt the table back to the rear as far as possible.
3. Using a square or protractor, measure the angle of the table against the platen (#84). FIG. E. To adjust the table angle to ensure a 90° angle, turn the table's rear adjustment screw (#61) as needed, and once the 90° is setting is found, lock it in place with the hex nut (#60), that is under the table.
4. To set the table to a different angle, tilt the table forward until it is at the required angle. FIG. F.
5. Tighten the table-locking lever to lock the table in position for sanding.

NOTE: To get the full range of table angling, the table-locking handle lever must be very loose, so that it slides along the slot in the table bracket. The table can then be moved back to get maximum angles.

INSTALLING & CHANGING SANDING DISCS

DISC TABLE ADJUSTMENTS

1. To check the trueness of the 90° angle of the disc-sanding table, place a square or other measuring device on the table with the other end against the sanding disc. FIG. G.

WARNING THE MACHINE MUST NOT BE PLUGGED IN AND THE POWER SWITCH MUST BE IN THE OFF POSITION UNTIL FULL ASSEMBLY AND ALL ADJUSTMENTS ARE COMPLETE.

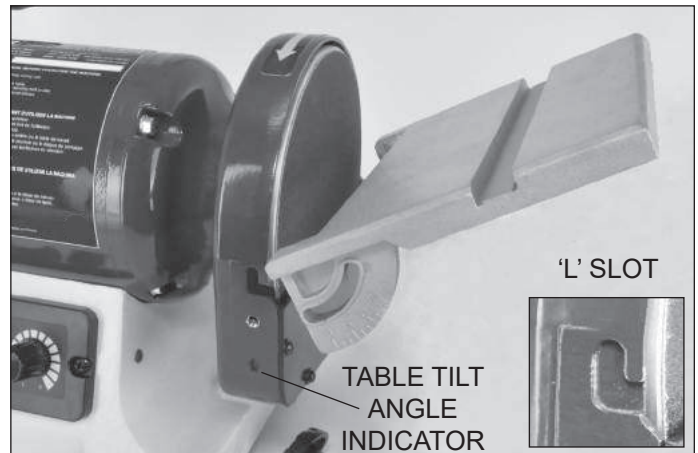

FIG. D

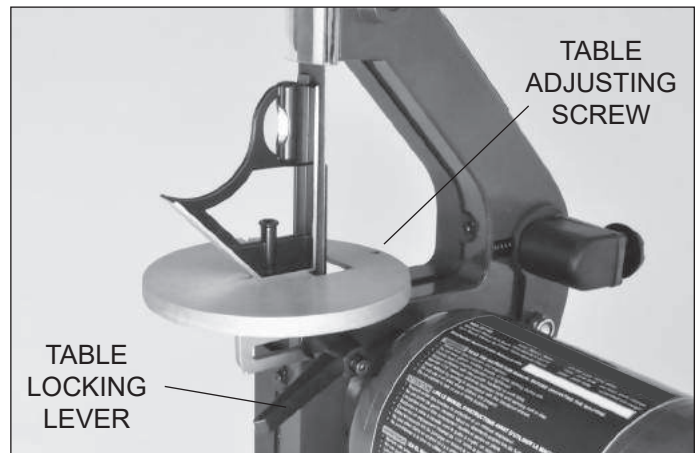

FIG. E

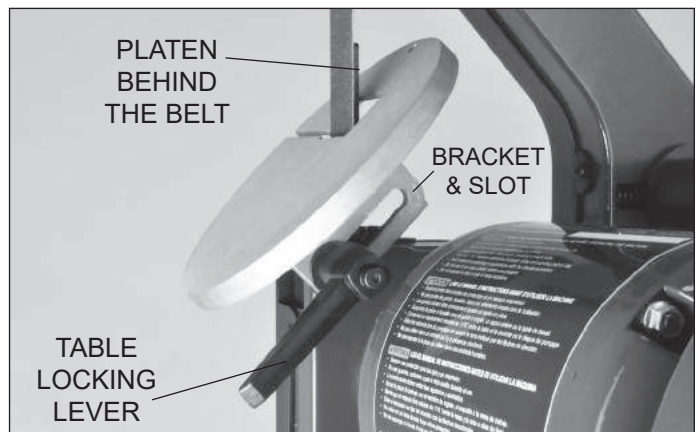

FIG. F

ADJUSTMENTS

DISC TABLE ADJUSTMENTS - continued

2. Loosen the 2 disc-table adjustment handles (#39), and adjust table angle to 90°.
3. Re-tighten the 2 disc-table adjustment handles.
4. To adjust the disc-table to another angle, loosen the 2 disc-table adjustment handles.
5. Set the table at the desired angle. FIG. H.
6. Re-tighten the 2 disc-table adjustment handles.

CHANGING THE SANDING DISC

NOTE: Sanding discs with pressure sensitive adhesive (PSA) backing cannot be used with this sander! Only Hook & Loop sanding discs can be used.

The sandpaper disc can be removed with the table installed or with the table removed to give more working access to the disc, if needed.

DISC CHANGING WITH THE TABLE REMOVED:

1. Remove and set aside the miter gauge.
2. Completely remove the 2 disc-table adjustment handles and washers (#39, 95, 94).
3. Tip the table up and remove it from the guard frame by slipping the table back out of the slots in the guard.
4. Remove the old disc paper, peel the protective backing from new sanding disc. Align perimeter of disc with sanding plate and press disc firmly into position all the way around. FIG. I.

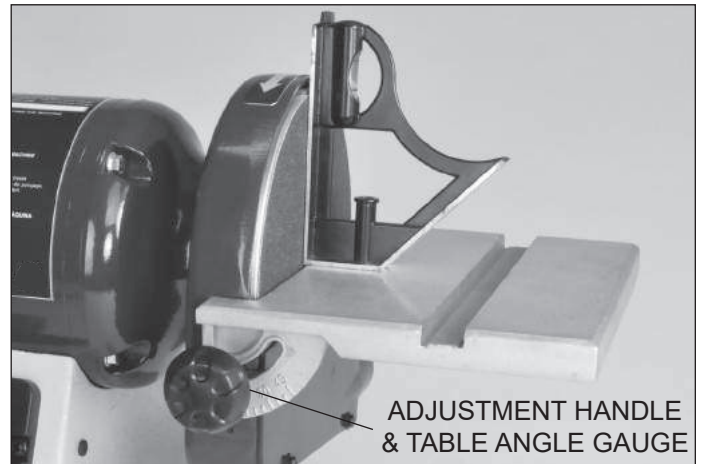

FIG. G

WARNING THE MACHINE MUST NOT BE PLUGGED IN AND THE POWER SWITCH MUST BE IN THE OFF POSITION UNTIL FULL ASSEMBLY AND ALL ADJUSTMENTS ARE COMPLETE.

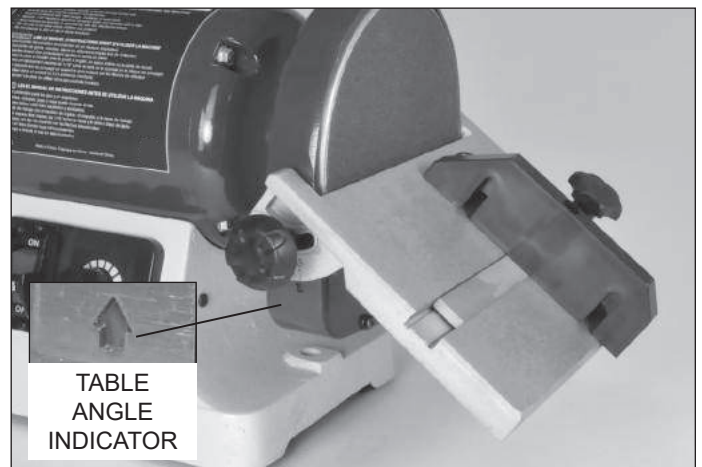

FIG. H



FIG. I

ADJUSTMENTS

INSTALLING & CHANGING SANDING BELTS

SANDING BELT REMOVAL:

1. Remove the top lock-knob (#52), clear plastic belt guard (#53), and three Phillips screws (#37) that secure the side cover (#54) to the sander's frame.
2. Remove the side cover.
3. Push the tracking knob forward release the belt tension. FIG. J.
4. Remove the belt from the three wheels.

SANDING BELT INSTALLATION:

5. Install the new belt around the top wheel, the large drive wheel, and then the rear idler wheel.

NOTE: the whole spring-loaded tracking knob assembly can be moved/pulled forward to assist in installing the belt over the last rear idler wheel.

6. Replace the side cover and re-install the 3 Phillips screws, clear top guard and lock-knob.
7. Before using, check the belt tracking as described in "Belt Tracking" section, and adjust as necessary.

BELT TRACKING

The belt-tracking adjustment is set at the factory so that the abrasive belt will run true on the pulleys. If, however, the belt should track to one side or the other, an adjustment can be made by turning the tracking knob (#80), which is located on the back side of the machine. FIG. J.

- Turning the knob *clockwise* will cause the belt to track to the right, towards the sander's frame.
- Turning the knob *counterclockwise* will cause the belt to track to the left, towards the side guard.

BELT SANDER PLATEN

The platen (# 84) is a heavy steel support plate that is positioned behind the sanding belt, rising from the table level to a point several inches above the table surface. Its purpose is to support the belt when sanding. The platen should be adjusted so that it is almost touching the back of the sanding belt. This can be done by loosening the two hex screws (#86) that fasten the bottom of the platen to the sander frame. If the platen is out of alignment for some reason, loosen these two screws, adjust the platen, and re-tighten the two screws. FIG. K.

To remove the platen for operations such as curved surface sanding, stropping, polishing or other special operations, remove the two screws that fasten the bottom of the platen to the frame, and remove the platen.

⚠ WARNING THE MACHINE MUST NOT BE PLUGGED IN AND THE POWER SWITCH MUST BE IN THE OFF POSITION UNTIL FULL ASSEMBLY AND ALL ADJUSTMENTS ARE COMPLETE.

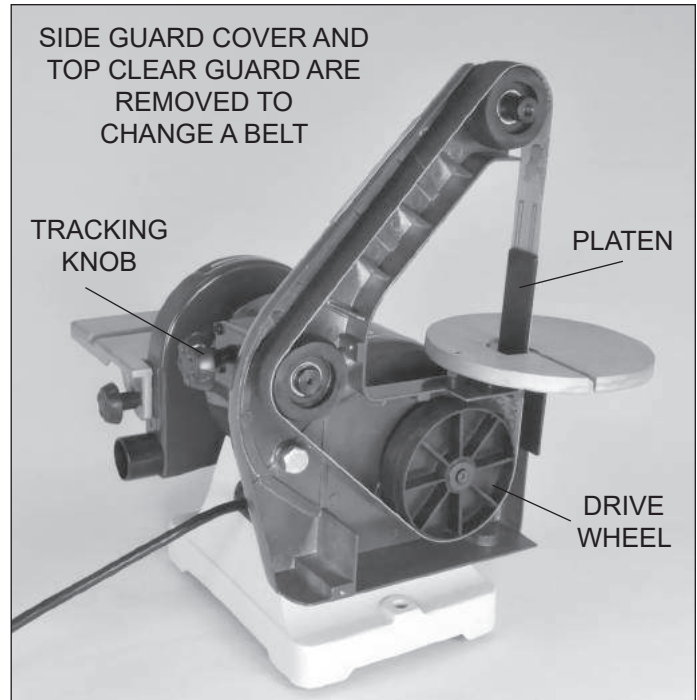

FIG. J

⚠ CAUTION Never walk away from sander when machine is running. Always lock the switch in the 'OFF' position and unplug from the power supply when not in use.

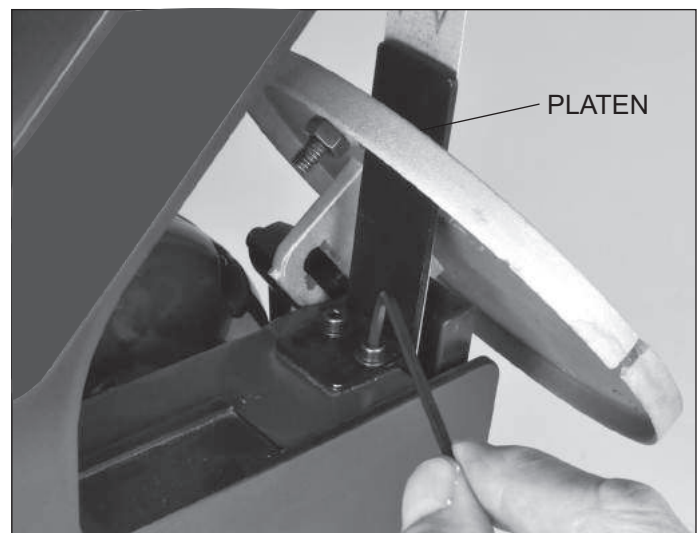

FIG. K

GENERAL USAGE

ON/OFF & VARIABLE SPEED SWITCHES

1. To start the machine, the Power Switch must be in the "OFF" position and the Variable Speed Switch must be turned to its slowest setting by being turned all the way to the left until solid resistance is felt. FIG. L.
2. Stand to the side of the sander and plug in the power cord to a suitable power source.
3. Remain to the side of the sander and turn it "ON" by moving the power switch to the up position.
4. Allow the sander to come up to a steady speed for at least one minute. The disc and belt RPM speed can then be increased to the desired speed for cleaning operation by rotating the Variable Speed Switch clockwise.
5. Place the work piece flat on the appropriate work table for the desired operation. Firmly hold onto the work piece.
6. When turning the sander OFF, also turn the Variable Speed Dial counterclockwise to return the sander to its slowest RPM setting.
7. Unplug the sander from the power source.

NOTE: To prevent unauthorized use of the sander, the power switch has a removable locking key. With the power switch in the "OFF" position, pull the locking key out. The sander machine cannot be turned "ON" with the key removed. Insert the locking key to resume sanding operations.

DUST CHUTES / PORTS

Sanding operations are inherently dusty. To help minimize the amount of dust that escapes into the surrounding air, this sander is equipped with two dust chutes (aka: ports) that can be easily connected to a dust-collection system. FIG. M.

There is one dust chute for the belt-sanding system and another for the disc-sanding system. Attach your dust collector to the proper dust chute according to which sanding mode (belt or disc) is being used.

MITER GAUGE

A miter gauge is supplied with your sander, and can be used on the disc table, which has a slot in its design to fit the miter gauge's bar. The miter gauge head can be set anywhere up to 45° (right or left) by loosening the lock-knob, setting the miter gauge head to the desired angle and re-tightening the lock-knob. FIG. N.

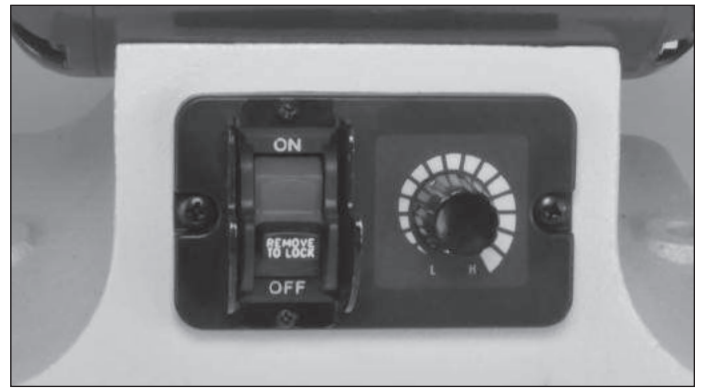

FIG. L

CAUTION Never start the machine with work in contact with the sanding belt or disk, or damage to the machine, your project, or personal injury may result from the sudden 'kick-back' of the parts.



FIG. M

NOTE: It is strongly recommended that users employ a dust-collection system when using this belt & disc sander. Use of a mask or respirator is still recommended, even when a dust-collection system is in use.

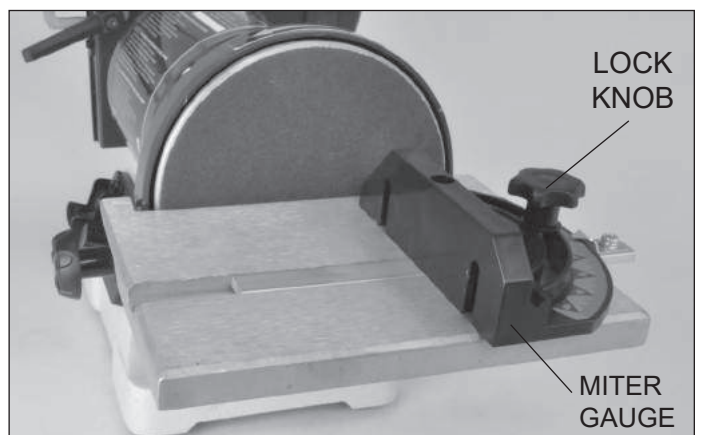

FIG. N

TROUBLESHOOTING

Service on these tools should only be performed by an authorized, qualified technician.

SYMPTOM	PROBABLE CAUSE	CORRECTIVE ACTION
Motor will not start.	<ol style="list-style-type: none"> 1. Low voltage 2. Open circuit in motor or loose connections. 3. Blown fuse or breaker. 4. Low temperature 	<ol style="list-style-type: none"> 1. Start the motor at high speed. 2. Inspect all lead connections on motor for loose or open connections. (Send for Servicing.) 3. Short circuit. (Send for Servicing.) 4. Improper match between tool and circuit, fuse or breaker.
<p>Motor will not start – fuses or circuit breakers tripping or blowing.</p> <p>Motor overheats.</p>	<ol style="list-style-type: none"> 1. Short circuit in line, cord or plug. 2. Short circuit in motor or loose connections. 3. Incorrect fuses or circuit breakers in power line. 4. Motor is overloaded. 5. Extension cord is too long and of insufficient gauge (weight). 6. Poor air circulation around the motor 	<ol style="list-style-type: none"> 1. Inspect cord or plug for damaged insulation and shorted wires. 2. Inspect all connections on motor for loose or shorted terminals and/or worn insulation. 3. Install correct fuses or circuit breakers or switch tool to an appropriately sized circuit. 4. Reduce load on motor (pressure on the sandpaper from the object being sanded.) 5. Utilize an extension cord of appropriate gauge and length or plug tool directly into outlet. 6. Reduce the motor run time.
Motor stalls or runs slow - resulting in blown fuses or tripped circuit.	<ol style="list-style-type: none"> 1. Motor is overloaded. 2. Short circuit in the motor or loose connections. 3. Low line voltage. 4. Incorrect fuses or circuit breakers in the power line. 5. Motor capacitor has failed. 6. Belt tension is too tight. 	<ol style="list-style-type: none"> 1. Reduce the load on the motor. 2. Inspect connections on motor for loose or shorted terminals or worn insulation. 3. Correct low voltage conditions (for example: improper extension cord length and/or wire gauge). 4. Install CORRECT fuses or circuit breakers or plug tool into an appropriate circuit, matched to an appropriate fuse or breaker. 5. Replace motor capacitor. 6. Decrease belt tension.
Machine slows down when operating.	<ol style="list-style-type: none"> 1. Feed rate is too great. 2. Undersized circuit or use of undersized extension cord. 	<ol style="list-style-type: none"> 1. Reduce the rate at which the work is fed into the sandpaper. 2. Ensure circuit wires or extension cords are proper gauge, or eliminate use of extension cords.
Machine vibrates excessively or makes excess noise.	<ol style="list-style-type: none"> 1. Incorrect motor mounting. 2. Incorrect sanding-belt tension. 3. Weak or broken belt tension spring. 4. Idler roller is too loose. 5. Broken/defective sanding belt or disc. 6. Drive belt is too tight 	<ol style="list-style-type: none"> 1. Make sure all fasteners are tightened. 2. Adjust tension-adjustment knob. Follow belt tensioning/tracking instructions in this manual. 3. Replace belt tension spring by service technician. 4. Have service technician adjust idler roller. 5. Replace sanding belt/disc. 6. Decrease belt tension.

EXPLODED VIEW

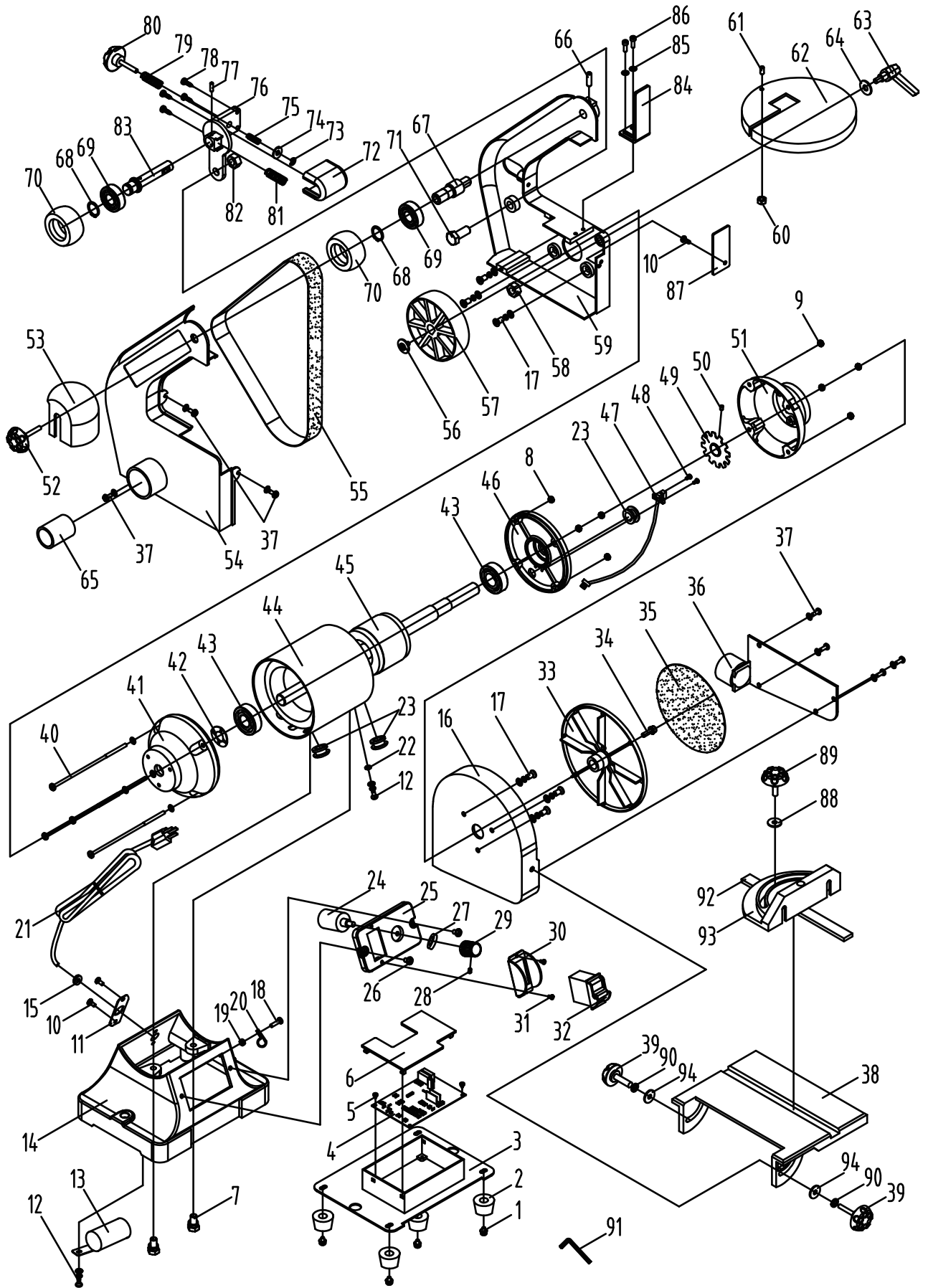

PARTS LIST

No.	Name	Spec	QTY
1	Screw+Large flat washer	M5X16	4
2	Rubber foot		4
3	Base plate		1
4	Circuit board		1
5	Screw	ST2.9x5	2
6	Circuit board box cover		1
7	Hexagon head bolt + spring washer	M8x22	2
8	Hexagon flange nut	M5	4
9	Hexagon flange nut	M5	4
10	Screw	M4X8	3
11	Wire card base plate		1
12	Screw+spring washer+washer	M4X8	2
13	Capacitor		1
14	Base		1
15	6P4		1
16	Sanding disc cover		1
17	Screw+spring washer+washer	M5X18	6
18	Screw	M4X16	1
19	Hexagon flange nut	M4	1
20	Wire fixing twist	(3/16)'	1
21	Power cord		1
22	External tooth lock washer	φ4	1
23	Lead wire sheath		3
24	Potentiometer		1
25	Switch Panel		1
26	Screw	M5X8	2
27	Knob rubber pad		1
28	Screw		1
29	Speed control handle		1
30	Switch guard		1
31	Screw	M3x10	2
32	Switch		1
33	Sanding disc plate		1
34	Screw+external tooth lock washers	M6X16	1
35	Sandpaper	150mm	1
36	Sand disc cover		1
37	Screw+washer	M4X8	7
38	Worktable		1
39	Worktable lock handle		2
40	Screw+washer	M5x160	4
41	Left end cap		1
42	Wave spring washer	D40	1
43	Deep groove ball bearing	6203RZ	2
44	Stator		1
45	Rotor		1
46	Right end cap		1
47	Feedback Line		1

No.	Name	Spec	QTY
48	Screw	M2.5X6	2
49	Feedback plate		1
50	Screw	M5x6	1
51	Right protective cover		1
52	Cover locking handle		1
53	Sanding belt shield		1
54	Sand belt support cover plate		1
55	Belt		1
56	Screw+washer	M5X16	1
57	Driver		1
58	Hexagon nut	M8	1
59	Sand belt support		1
60	Hexagon nut	M6	1
61	Screw	M6X20	1
62	Sanding belt table		1
63	Locking handle assembly		1
64	Large washer	φ8	1
65	Dust port connecting pipe		1
66	Screw	M6X8	1
67	Driven shaft		1
68	Circlip for shaft	φ15	2
69	Deep groove ball bearing	6202RZ	2
70	Driven pulley		2
71	Hexagon head bolt	M10X25	1
72	Adjust shaft guard		1
73	Split washer	φ3.5	1
74	Large washer	φ5	1
75	Adjustment springII		1
76	Adjustment of the fixing plate		1
77	Flexible cylindrical pin	3X20	1
78	Self-tapping screws	4.2X16	4
79	Adjustment springI		1
80	Adjustment handle		1
81	Adjustment spring		1
82	Lock nut	M10	1
83	Adjustment shaft		1
84	Sanding belt limit plate		1
85	Washer	φ4	2
86	Hexagon cylindrical head bolt	M4X10	2
87	Sand belt protection plate		1
88	Large washer	φ6	1
89	Handle of indexing plate		1
90	Lightened spring washer	φ6	2
91	Allen wrench		1
92	Miter bar		1
93	Table index plate		1
94	Washer	φ6	2

