



WARNING

EUROPEAN USERS

400V 50Hz SUPPLY DETAILS ARE INCLUDED WITH ELECTRICAL CONTROL BOX. DISREGARD SUPPLY WIRING DETAILS IN THIS MANUAL

IMPORTANT SAFETY INSTRUCTIONS SAVE THESE INSTRUCTIONS

PLEASE READ THE ENTIRE CONTENTS OF THIS MANUAL PRIOR TO INSTALLATION AND OPERATION. BY PROCEEDING WITH LIFT INSTALLATION AND OPERATION YOU AGREE THAT YOU FULLY UNDERSTAND THE FULL CONTENTS OF THIS MANUAL. FORWARD THIS MANUAL TO ALL OPERATORS. FAILURE TO OPERATE THIS EQUIPMENT AS DIRECTED MAY CAUSE INJURY OR DEATH.

Rev. C – March 2017
Manual P/N 5900951

INSTALLATION AND OPERATION MANUAL

10,000 LB / 4,536 KG CAPACITY SURFACE MOUNTED TWO-POST LIFTS

MODELS:

- XPR-10S
- XPR-10S-LP
- XPR-10S-168
- XPR-10S-168-LP
- XPR-10TS
- XPR-10TS-168
- XPR-10AXLS
- XPR-10AS
- XPR-10AS-LP
- XPR-10AS-168
- XPR-10AS-168-LP



Symmetrical model shown.



ORIGINAL INSTRUCTIONS IN
ENGLISH LANGUAGE

RECEIVING

The shipment should be thoroughly inspected as soon as it is received. The signed Bill of Lading is acknowledgement by the shipping carrier as receipt of this product as listed in your invoice as being in a good condition of shipment. If any of these goods listed on this Bill of Lading are missing or damaged, do not accept goods until the shipping carrier makes a notation on the freight bill of the missing or damaged goods. Do this for your own protection.

BE SAFE

Your new lift was designed and built with safety in mind. However, your overall safety can be increased with proper training and thoughtful operation on the part of the operator. DO NOT operate or repair this equipment without reading this manual and the important safety instructions shown inside. Keep this operation manual near the lift at all times. Make sure that ALL USERS read and understand this manual.



1645 Lemonwood Dr.
Santa Paula, CA. 93060, USA
Toll Free 1-800-253-2363
Tel: 1-805-933-9970
Fax: 1-805-933-9160
www.bendpak.com

10,000 LB / 4,536 KG CAPACITY SURFACE MOUNTED TWO-POST AUTO LIFTS

This instruction manual has been prepared especially for you.
Your new lift is the product of over 40 years of continuous research, testing, and development;
it is the most technically advanced lift on the market today.

READ THIS ENTIRE MANUAL BEFORE INSTALLATION & OPERATION BEGINS!

Record here the lift and power unit information that is located on the serial number data plates on the lift and on the power unit.

Power Unit Model # _____
Power Unit Date Of Mfg. _____
Power Unit Serial # _____
Max Operating Pressure 2.650 PSI

This information is required when
calling for parts or warranty issues.

BP BendPak Santa Paula, CA USA www.bendpak.com	
MODEL NUMBER	
SERIAL NUMBER	
LIFT CAPACITY	DESCRIPTION
VOLTAGE	
<input type="checkbox"/> 110-240VAC, 50-60 Hz, 1 Ph	<input type="checkbox"/> 380-415VAC, 50-60 Hz, 3 Ph
<input type="checkbox"/> 208-240VAC, 50-60 Hz, 1 Ph	<input type="checkbox"/> 208-440VAC, 50-60 Hz, 3 Ph
DATE OF MFG.	
DANGER! Disconnect Power Before Servicing	
WARRANTY VOID IF DATA PLATE IS REMOVED PN 5905950	
CE EAC	

Product Warranty

Our comprehensive product warranty means more than a commitment to you; it's also a commitment to the value of your new BendPak lift. For full warranty details and to register your new lift contact your nearest BendPak dealer or visit:

www.bendpak.com/support/warranty/

What is **not** covered by your warranty:

- Any failure that results from purchaser's abuse, neglect, or failure to operate, maintain, or service the product in accordance with instructions provided in the supplied owner's manual(s).
- Any damage caused by overloading the lift beyond its rated capacity.
- Items or service normally required to maintain the product; for example, lubricants, oil, and so on.
- Items considered general wear parts such as rubber pads, lifting cables, and so on unless wear or failure is a direct result of manufacturer defect due to material and/or workmanship.
- Any component damaged in shipment or any failure caused by installing or operating the lift under conditions not in accordance with installation and operation guidelines or damaged by contact with tools or surroundings.
- Motor or pump failure caused by rain, excessive humidity, corrosive environments, or other contaminants.
- Rusted components due to improper maintenance or corrosive environments.
- Cosmetic defects that do not interfere with product functionality.
- Damage due to incorrect voltage or improper wiring.
- Any incidental, indirect, or consequential loss, damage, or expense that may result from any defect, failure, or malfunction of the BendPak, Inc. product.

All electrical components (excluding power unit) are guaranteed for one year against defects in workmanship and/or materials when the lift is installed and used according to specifications.

NOTE:

Every effort has been taken to ensure complete and accurate instructions have been included in this manual, however, possible product updates, revisions and or changes may have occurred since this printing. BendPak Ranger reserves the right to change specifications without incurring any obligation for equipment previously or subsequently sold.

Not responsible for typographical errors.

IMPORTANT NOTICE

Do not attempt to install this lift if you have never been trained on basic automotive lift installation procedures. Never attempt to lift components without proper lifting tools such as forklift or cranes. Stay clear of any moving parts that can fall and cause injury. These instructions must be followed to insure proper installation and operation of your lift. Failure to comply with these instructions can result in serious bodily harm and void product warranty. Manufacturer will assume no liability for loss or damage of any kind, expressed or implied resulting from improper installation or use of this product.



**PLEASE READ ENTIRE MANUAL
PRIOR TO INSTALLATION**

DEFINITIONS OF HAZARD LEVELS

Identify the hazard levels used in this manual with the following definitions and signal words:



Watch for this symbol: It Means: Immediate hazards which will result in severe personal injury or death.



Watch for this symbol: It Means: Hazards or unsafe practices which could result in severe personal injury or death.



Watch for this symbol. It Means: Hazards or unsafe practices which may result in minor personal injury, product or property damage.

OWNER'S RESPONSIBILITY

To maintain the lift and user safety, the responsibility of the owner is to read and follow these instructions:

- ◆ Follow all installation and operation instructions.
- ◆ Make sure installation conforms to all applicable Local, State, and Federal Codes, Rules, and Regulations; such as State and Federal OSHA Regulations and Electrical Codes.
- ◆ Carefully check the lift for correct initial function.
- ◆ Read and follow the safety instructions. Keep them readily available for machine operators.
- ◆ Make certain all operators are properly trained, know how to safely and correctly operate the unit, and are properly supervised.
- ◆ Allow unit operation only with all parts in place and operating safely.
- ◆ Carefully inspect the unit on a regular basis and perform all maintenance as required.
- ◆ Service and maintain the unit only with authorized or approved replacement parts.
- ◆ Keep all instructions permanently with the unit and all decals on the unit clean and visible.

BEFORE YOU BEGIN

Receiving:

The shipment should be thoroughly inspected as soon as it is received. The signed bill of lading is acknowledgement by the carrier of receipt in good condition of shipment covered by your invoice. If any of the goods called for on this bill of lading are shorted or damaged, do not accept them until the carrier makes a notation on the freight bill of the shorted or damaged goods. Do this for your own protection.

NOTIFY THE CARRIER AT ONCE if any hidden loss or damage is discovered after receipt and request the carrier to make an inspection. If the carrier will not do so, prepare a signed statement to the effect that you have notified the carrier (on a specific date) and that the carrier has failed to comply with your request.

IT IS DIFFICULT TO COLLECT FOR LOSS OR DAMAGE AFTER YOU HAVE GIVEN THE CARRIER A CLEAR RECEIPT. File your claim with the carrier promptly. Support your claim with copies of the bill of lading, freight bill, invoice, and photographs, if available. Our willingness to assist in helping you process your claim does not make BendPak responsible for collection of claims or replacement of lost or damaged materials.

TABLE OF CONTENTS

Warranty / Serial Number Information	2
Definitions of Hazard Levels	3
Owner's Responsibility	3
Before You Begin	3
Installer/Operator Agreement/ Protective Equipment	5
Introduction	6
Safety / Warning Instructions	6
Tools Required	7
Step 1 / Selecting Site	7
Step 2 / Floor Requirements	7
Concrete Specifications	7
Assembly View / Description of Parts	8
Floor Plan	9 - 11
Clearances	12 - 13
Step 3 / Post Preparation	14 - 15
Equalizer Cable Routing	16
Hose Routing	17
Step 4 / Site Layout	18
Step 5 / Installing Power Side Post	18 - 19
Step 6 / Installing Off Side Post	19
Step 7 / Mounting The Overhead Assembly	19 - 20
Step 8 / Mounting The Hydraulic Power Unit	20 - 21
Step 9 / Installing the Safeties and Safety Cable	21 - 22
Step 10 / Installing Hydraulic Lines	23
Step 11 / Routing the Equalizer Cables	23 - 24
Step 12 / Installing Overhead Microswitch	24 - 25
Step 13 / Installing Power Unit Hose Assembly and Power Side Safety Cover	25 - 26
Step 14 / Installing the Lift Arms	26 - 27
Carriage Stop Bolt Installation Warning	28 - 29
Step 15 / Power Unit Connection	30 - 32
Step 16 / Lift Start Up Final Adjustments	32
Post Installation Checklist	33
Step 17 / Lubrication	33
Step 18 / Bleeding the Cylinders	33
Optional Equipment Installation / Optional Accessories	34 - 36
Step 19 / Operation/ Maintenance	37 - 47
Troubleshooting Guide	48 - 51
Torque Recommendations	51
Installation Form	52
Part Number Lists	53 - 73
CE Certificate	74
Declaration of Conformity	75

**INSTALLER / OPERATOR
PLEASE READ AND FULLY
UNDERSTAND.
BY PROCEEDING YOU AGREE TO
THE FOLLOWING:**

- ◆ I have visually inspected the site where the lift is to be installed and verified the concrete to be in good condition and free of cracks or other defects. I understand that installing a lift on cracked or defective concrete could cause lift failure resulting in personal injury or death.
- ◆ I understand that a level floor is required for proper installation and level lifting.
- ◆ I understand that I am responsible if my floor is of questionable slope and that I will be responsible for all charges related to pouring a new level concrete slab, if required.
- ◆ I understand that the lifts are supplied with concrete fasteners meeting the criteria of the American National Standard "Automotive Lifts - Safety Requirements for Construction, Testing, and Validation" ANSI/ALI ALCTV-2011, and that I will be responsible for all charges related to any special regional structural and/or seismic anchoring requirements specified by any other agencies and/or codes such as the Uniform Building Code (UBC) and/or International Building Code (IBC).
- ◆ I will assume full responsibility for the concrete floor and condition thereof, now or later, where the above equipment model(s) are to be installed. Failure to follow danger, warning, and caution instructions may lead to serious personal injury or death to operator or bystander or damage to property.
- ◆ I understand that Bendpak lifts are designed to be installed in indoor locations only. Failure to follow installation instructions may lead to serious personal injury or death to operator or bystander or damage to property or lift.



Failure to follow danger, warning, and caution instructions may lead to serious personal injury or death to operator or bystander or damage to property.



THIS SYMBOL POINTS OUT IMPORTANT SAFETY INSTRUCTIONS WHICH IF NOT FOLLOWED COULD ENDANGER THE PERSONAL SAFETY AND/OR PROPERTY OR YOURSELF AND OTHERS AND CAN CAUSE PERSONAL INJURY OR DEATH. READ AND FOLLOW ALL INSTRUCTIONS IN THIS MANUAL BEFORE ATTEMPTING TO OPERATE THIS MACHINE.



Please read entire manual prior to installation. Do not operate this machine until you read and understand all the dangers, warnings and cautions in this manual.

For additional copies or further information, contact:

BendPak Inc. / Ranger Products
1645 Lemonwood Dr.
Santa Paula, CA. 93060
1-805-933-9970
www.bendpak.com

**INSTALLER / OPERATOR
PROTECTIVE EQUIPMENT**

Personal protective equipment helps makes installation and operation safer, however, it does not take the place of safe operating practices. Always wear durable work clothing during any installation and/or service activity. Shop aprons or shop coats may also be worn, however, loose fitting clothing should be avoided. Tight fitting leather gloves are recommended to protect technician hands when handling parts. Sturdy leather work shoes with steel toes and oil resistant soles should be used by all service personnel to help prevent injury during typical installation and operation activities.

Eye protection is essential during installation and operation activities. Safety glasses with side shields, goggles, or face shields are acceptable. Back belts provide support during lifting activities and are also helpful in providing worker protection. Consideration should also be given to the use of hearing protection if service activity is performed in an enclosed area or if noise levels are high.



INTRODUCTION

1. Carefully remove the crating and packing materials. **CAUTION!** Be careful when cutting steel banding material as items may become loose and fall causing personal harm or injury.

2. Check the voltage, phase and proper amperage requirements for the motor shown on the motor plate. Wiring should be performed by a certified electrician only.

IMPORTANT SAFETY INSTRUCTIONS

Read these safety instructions entirely

IMPORTANT NOTICE

Do not attempt to install this lift if you have never been trained on basic automotive lift installation procedures.

Never attempt to lift components without proper lifting tools such as forklift or cranes.

Stay clear of any moving parts that can fall and cause injury.

1. Read and understand all instructions and all safety warnings before operating lift.
2. Care must be taken as burns can occur from touching hot parts.
3. Do not operate equipment with a damaged cord or if the equipment has been dropped or damaged until it has been examined by a qualified service person.
4. Do not let a cord hang over the edge of the table, bench, or counter or come in contact with hot manifolds or moving fan blades.
5. If an extension cord is necessary, a cord with a current rating equal to or more than that of the equipment should be used. Cords rated for less current than the equipment may overheat. Care should be taken to arrange the cord so that it will not be tripped over or pulled.
6. Always unplug equipment from electrical outlet when not in use. Never use the cord to pull the plug from the outlet. Grasp plug and pull to disconnect.
7. Let equipment cool completely before putting away. Loop cord loosely around equipment when storing.
8. To reduce the risk of fire, do not operate equipment in the vicinity of open containers of flammable liquids (gasoline).
9. Adequate ventilation should be provided when working on operating internal combustion engines.
10. Keep hair, loose clothing, fingers, and all parts of body away from moving parts. Keep feet clear of lift when lowering. Avoid pinch points.
11. **DANGER!** To reduce the risk of electric shock, do not use on wet surfaces or expose to rain. The power unit used on this lift contains high voltage. Disconnect power at the receptacle or at the circuit breaker switch before performing any electrical repairs. Secure plug so that it cannot be accidentally plugged in during service, or mark circuit breaker switch so that it cannot be accidentally switched on during service.
12. Use only as described in this manual. Use only manufacturer's recommended attachments.



13. **ALWAYS WEAR SAFETY GLASSES.** Everyday eyeglasses only have impact resistant lenses, they are not safety glasses.
14. Consider work environment. Keep work area clean. Cluttered work areas invite injuries. Keep areas well lit.
15. Guard against electric shock. This lift must be grounded while in use to protect operator from electric shock. Never connect the green power cord wire to a live terminal. This is for ground only.
16. Only trained operators should operate this lift. All non-trained personnel should be kept away from the work area. Never let non-trained personnel come in contact with, or operate lift.
17. **DO NOT** override self-closing lift controls.
18. Clear area if vehicle is in danger of falling.
19. **ALWAYS** make sure the safeties are engaged before attempting to work on or near a vehicle.
21. **WARNING! RISK OF EXPLOSION.** This equipment has internal arcing or sparking parts which should not be exposed to flammable vapors. This machine should not be located in a recessed area or below floor level.
22. **MAINTAIN WITH CARE.** Keep lift clean for better and safer performance. Follow manual for proper lubrication and maintenance instructions. Keep control handles and/or buttons dry, clean and free from grease and oil.
23. Check for damaged parts. Check for alignment of moving parts, breakage of parts or any condition that may affect operation of lift. Do not use lift if any component is broken or damaged.
24. **NEVER** remove safety related components from the lift. Do not use lift if safety related components are missing or damaged.
23. **STAY ALERT.** Use common sense and watch what you are doing. Remember, **SAFETY FIRST.**



SAVE THESE INSTRUCTIONS

TOOLS REQUIRED

- ◆ Rotary Hammer Drill or Similar
- ◆ 3/4" Masonry Bit
- ◆ Hammer
- ◆ 4 Foot Level
- ◆ Open-End Wrench Set: SAE/Metric
- ◆ Socket And Ratchet Set: SAE/Metric
- ◆ Hex-Key / Allen Wrench Set
- ◆ Large Crescent Wrench
- ◆ Large Pipe Wrench
- ◆ Crow Bar
- ◆ Chalk Line
- ◆ Medium Flat Screwdriver
- ◆ Tape Measure: 25 Foot Minimum
- ◆ Needle Nose Pliers

IMPORTANT NOTICE

THESE INSTRUCTIONS MUST BE FOLLOWED TO INSURE PROPER INSTALLATION AND OPERATION OF YOUR LIFT. FAILURE TO COMPLY WITH THESE INSTRUCTIONS CAN RESULT IN SERIOUS BODILY HARM AND VOID PRODUCT WARRANTY. MANUFACTURER WILL ASSUME NO LIABILITY FOR LOSS OR DAMAGE OF ANY KIND, EXPRESSED OR IMPLIED, RESULTING FROM IMPROPER INSTALLATION OR USE OF THIS PRODUCT.

PLEASE READ ENTIRE MANUAL PRIOR TO INSTALLATION

STEP 1

(Selecting Site)

Before installing your new lift, check the following.

1. **LIFT LOCATION:** Always use architect's plans when available. Check layout dimension against floor plan requirements making sure that adequate space is available.
2. **OVERHEAD OBSTRUCTIONS:** The area where the lift will be located should be free of overhead obstructions such as heaters, building supports, electrical lines etc.
3. **DEFECTIVE FLOOR:** Visually inspect the site where the lift is to be installed and check for cracked or defective concrete.



4. Lift is designed for **INDOOR INSTALLATION ONLY**. Outdoor use permitted only if covered and dry. Always follow warnings illustrated on equipment labels.

STEP 2

(Floor Requirements)



This lift must be installed on a solid level concrete floor with no more than 3°s of slope. Failure to do so could cause personal injury or death.

A level floor is suggested for proper use and installation and level lifting. If a floor is of questionable slope, consider a survey of the site and/or the possibility of pouring a new level concrete slab.



- ◆ DO NOT install or use this lift on any asphalt surface or any surface other than concrete.
- ◆ DO NOT install or use this lift on expansion seams or on cracked or defective concrete.
- ◆ DO NOT install or use this lift on a second / elevated floor without first consulting a building architect.

CONCRETE SPECIFICATIONS

LIFT MODEL	CONCRETE REQUIREMENTS
XPR-10S/10AS SERIES	4" Min. Thickness / 3,000 PSI



ALL MODELS MUST BE INSTALLED ON 3000 PSI CONCRETE ONLY CONFORMING TO THE MINIMUM REQUIREMENTS SHOWN ABOVE. NEW CONCRETE MUST BE ADEQUATELY CURED FOR A MINIMUM OF 28 DAYS.

IMPORTANT NOTE

BendPak lifts are supplied with installation instructions and concrete fasteners meeting the criteria as prescribed by the American National Standard "Automotive Lifts - Safety Requirements for Construction, Testing, and Validation" ANSI/ALI ALCTV-2011. Lift buyers are responsible for any special regional structural and/or seismic anchoring requirements specified by any other agencies and/or codes such as the Uniform Building Code (UBC) and/or International Building Code (IBC).



When removing the lift from shipping angles, pay close attention as the posts can slide and can cause injury. Prior to removing the bolts make sure the posts are held securely by a fork lift or some other heavy lifting device.

PARTS INVENTORY

Be sure to take a complete inventory of parts prior to beginning installation.

Description	Qty
Overhead Assembly	1
Front Lift Arm Assembly	2
Rear Lift Arm Assembly	2
Off Side Post with Carriage Assembly	1
Power Side Post with Carriage Assembly	1
Hydraulic Cylinder	2
Parts Box (Packing List Enclosed)	1
Parts Bag (Packaged in Part Box)	1
Hydraulic Power Unit	1

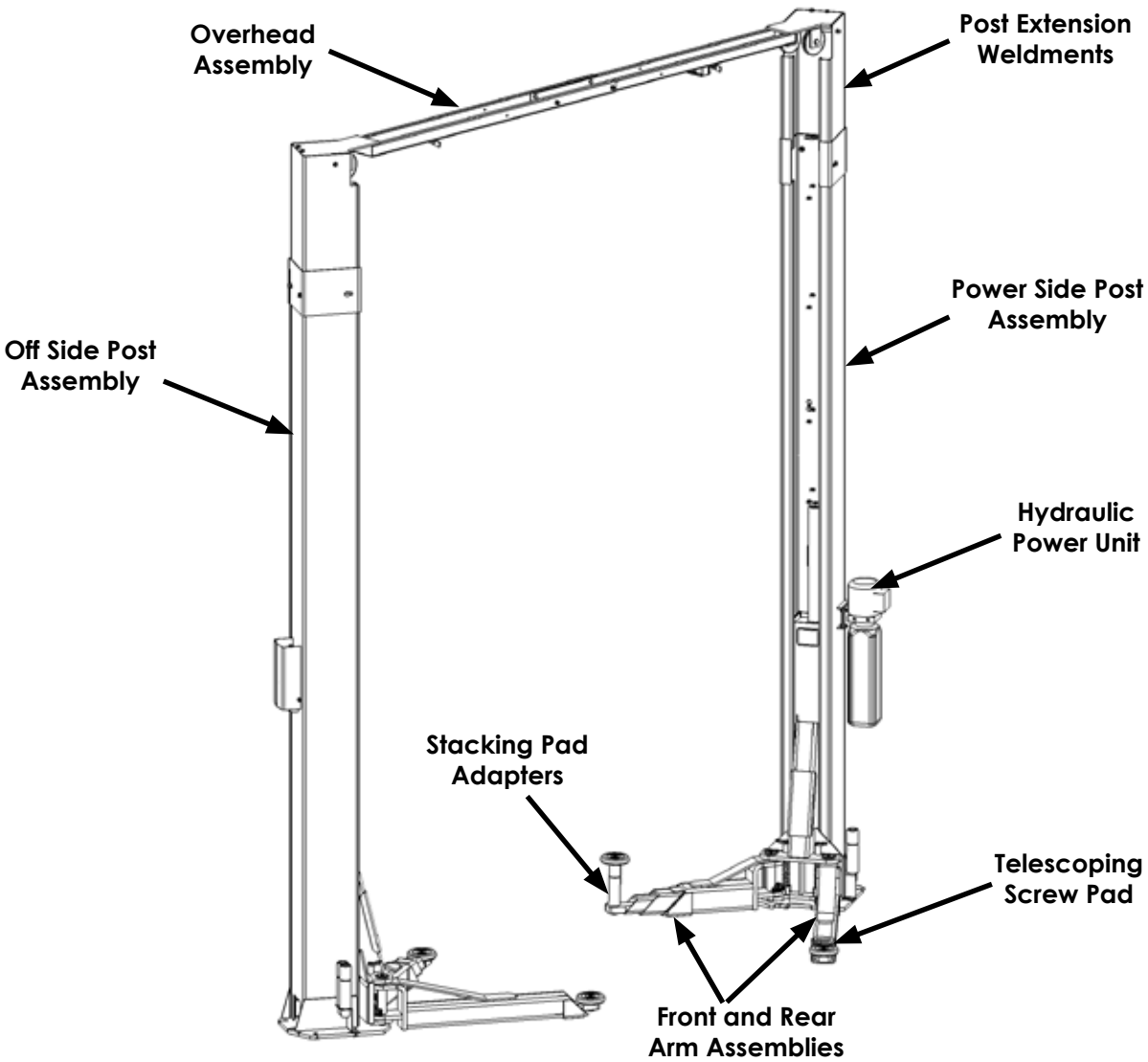

FLOOR PLAN

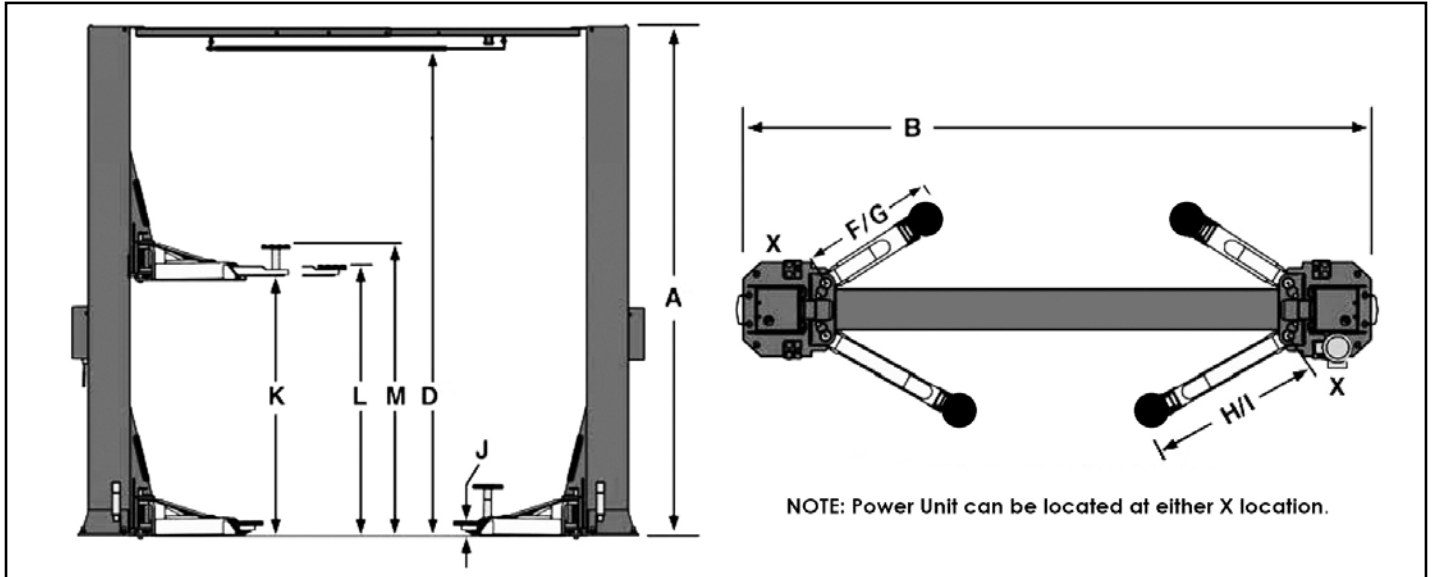

MODEL	XPR-10S	XPR-10TS	XPR-10S-LP
Lifting Capacity	10,000Lbs. / 4536Kg.	10,000Lbs. / 4536Kg.	10,000Lbs. / 4536Kg.
Max Capacity/ Front Axle	5,000Lbs. / 2268Kg.	5,000Lbs. / 2268Kg.	5,000Lbs. / 2268Kg.
Max Capacity/ Rear Axle	5,000Lbs. / 2268Kg.	5,000Lbs. / 2268Kg.	5,000Lbs. / 2268Kg.
A- Height Overall(*):	145" / 3683mm. (*)	145" / 3683mm. (*)	145" / 3683mm. (*)
B -Width Overall -NARROW CONFIGURATION	132" / 3353mm.	132" / 3353mm.	132" / 3353mm.
B -Width Overall -WIDE CONFIGURATION	145" / 3683mm.	145" / 3683mm.	145" / 3683mm.
D- Floor to Overhead Switch:	141" / 3581mm. (*)	141" / 3532mm. (*)	141" / 3532mm. (*)
F -Reach (Front Arm Min.):	27-1/2" / 698mm.	27-1/2" / 698mm.	28-1/2" / 724mm
G -Reach (Front Arm Max.):	51-1/2" / 1308mm.	51-1/2" / 1308mm.	47-1/2" / 1206mm.
H- Reach (Rear Arm Min.):	34" / 863mm.	27-1/2" / 698mm.	28-1/2" / 698mm.
I- Reach (Rear Arm Max.):	54-1/2" / 1384mm.	51-1/2" / 1308mm.	47-1/2" / 1206mm.
J- Min. Pad Height:	4.25" - 6-3/4" / 102mm	4.25" - 6-3/4" / 102mm.	4.25" - 6-3/4" / 102mm.
Screw Pad Adjustment	2" / 51mm	2" / 51mm	2" / 51mm
K- Rise:	69" / 1753mm.	69" / 1753mm.	69" / 1753mm.
L -Max Lift Height (Pad Only):	73"- 75"/1854mm-1905mm	73"- 75"/1854mm-1905mm	73"-75"/1854mm-1905mm
M - Max Lift Height (3" Adapter):	75.5"-77.5"/1917mm-1968	75.5"-77.5"/1917mm-1968	75.5"-77.5"/1917mm-1968
Standard Motor(**)	220VAC / 60Hz.1Ph.	220VAC / 60Hz.1Ph.	220VAC / 60Hz.1Ph.
Time of Full Rise:	45 Seconds	45 Seconds	45 Seconds
Max Load Per Arm:	2,500Lbs. / 1134Kg.	2,500Lbs. / 1134Kg.	2,500Lbs. / 1134Kg.
Emission sound pressure at Operator Position < 70 dB(A)			
* An optional bolt-on top extension for columns raises the overhead bar an additional 24". Must be ordered from factory at time of order.			
** Special Voltages Available Upon Request			
The design, material and specifications are subject to change without notice.			

FLOOR PLAN

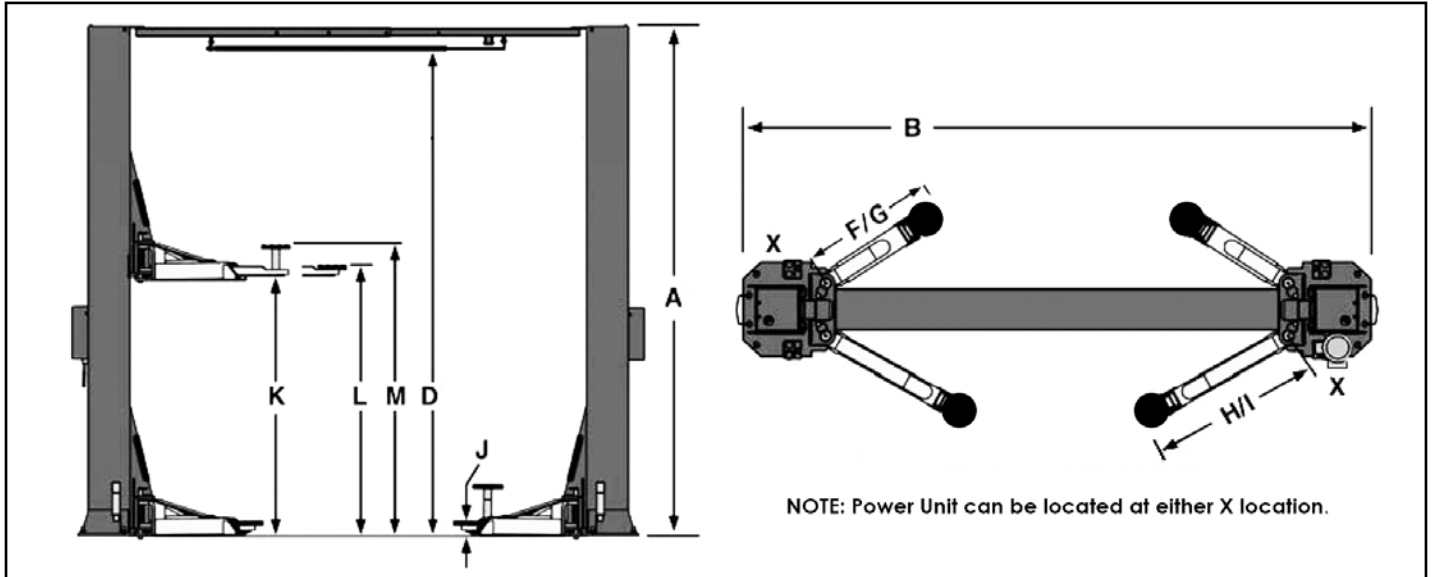

MODEL	XPR-10S-168	XPR-10TS-168	XPR-10S-168-LP	XPR-10AXLS
Lifting Capacity	10,000Lbs. / 4536Kg.	10,000Lbs. / 4536Kg.	10,000Lbs. / 4536Kg.	10,000Lbs. / 4536Kg.
Max Capacity/ Front Axle	5,000Lbs. / 2268Kg.	5,000Lbs. / 2268Kg.	5,000Lbs. / 2268Kg.	5,000Lbs. / 2268Kg.
Max Capacity/ Rear Axle	5,000Lbs. / 2268Kg.	5,000Lbs. / 2268Kg.	5,000Lbs. / 2268Kg.	5,000Lbs. / 2268Kg.
A- Height Overall(*):	169" / 4293mm.	169" / 4293mm.	169" / 4293mm.	156.8" / 3983mm.
B -Width Overall (narrow config)	132" / 3353mm.	132" / 3353mm.	132" / 3353mm.	106.3" / 2700mm.
B -Width Overall (wide config)	145" / 3683mm.	145" / 3683mm.	145" / 3683mm.	114.3" / 2903mm.
D- Floor to Overhead Switch:	165" / 4191mm.	165" / 4191mm.(*)	165" / 4191mm.(*)	152.8" / 3881mm.(*)
F -Reach (Front Arm Min.):	27-1/2" / 698mm.	27-1/2" / 698mm.	28-1/2" / 724mm.	23.4" / 595mm.
G -Reach (Front Arm Max.):	51-1/2" / 1308mm.	51-1/2" / 1308mm.	47-1/2" / 1206mm.	43.7" / 1110mm.
H- Reach (Rear Arm Min.):	34" / 863mm.	27-1/2" / 698mm.	28-1/2" / 724mm.	40" / 1024mm.
I- Reach (Rear Arm Max.):	54-1/2" / 1384mm.	51-1/2" / 1308mm.	47-1/2" / 1206mm.	58" / 1474mm.
J- Min. Pad Height:	4" / 102mm.	4" / 102mm.	4-1/4" / 110mm.	4-1/4" / 110mm.
K- Rise:	69" / 1753mm.	69" / 1753mm.	69" / 1753mm.	75" / 1905mm.
L -Max Lift Height (Pad Only):	73"- 75"/1854mm-1905mm	73"- 75"/1854mm-1905mm	73"- 75"/1854mm-1905mm	73"- 75"/1854mm-1905mm
M - Max Lift Height (6" Adapter):	75.5"-77.5"/1917mm-1968	75.5"-77.5"/1917mm-1968	75.5"-77.5"/1917mm-1968	75.5"-77.5"/1917mm-1968
Standard Motor(**)	220VAC / 60Hz.1Ph.	220VAC / 60Hz.1Ph.	220VAC / 60Hz.1Ph.	220VAC / 60Hz.1Ph.
Time of Full Rise:	45 Seconds	45 Seconds	45 Seconds	45 Seconds
Max Load Per Arm:	2,500Lbs. / 1134Kg.	2,500Lbs. / 1134Kg.	2,500Lbs. / 1134Kg.	2,500Lbs. / 1134Kg.
Emission sound pressure at Operator Position < 70 dB(A)				
* Optional bolt-on extension for columns raises the overhead bar an additional 24". Must be ordered from factory at time of order.				
** Special voltages available on request.				
Design, material, and specifications are subject to change without notice.				

FLOOR PLAN

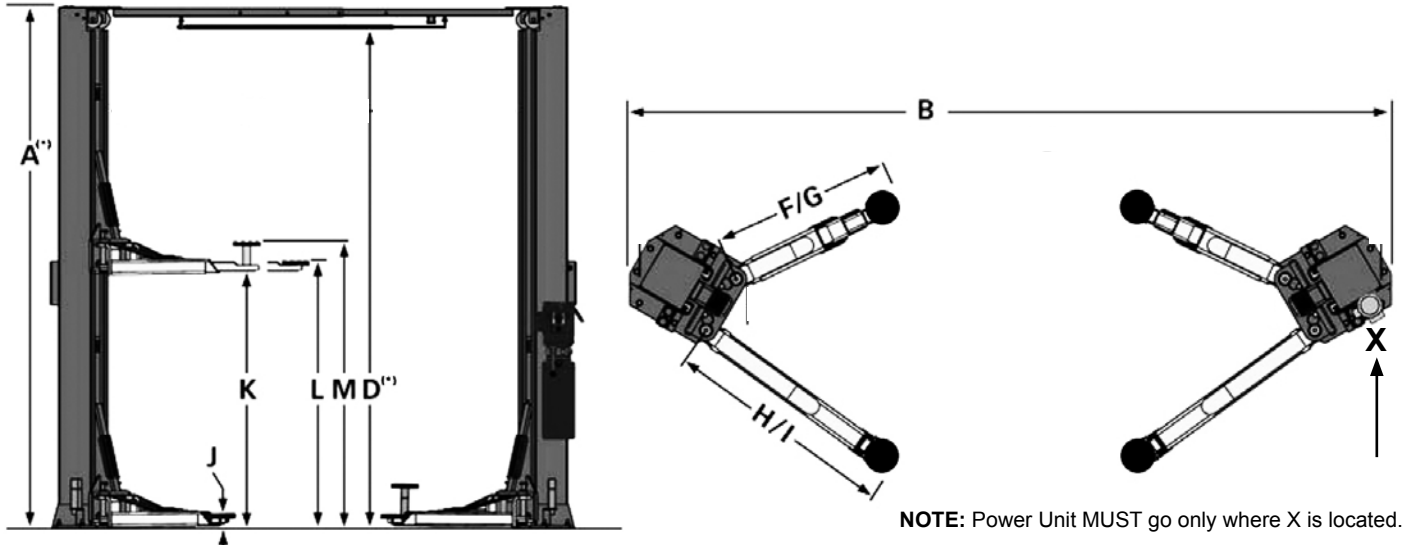

MODEL	XPR-10AS	XPR-10AS-168	XPR-10AS-LP	XPR-10AS-168-LP
Lifting Capacity	10,000Lbs. / 4536Kg.	10,000Lbs. / 4536Kg.	10,000Lbs. / 4536Kg.	10,000Lbs. / 4536Kg.
Max Capacity/ Front Axle	5,000Lbs. / 2268Kg.	5,000Lbs. / 2268Kg.	5,000Lbs. / 2268Kg.	5,000Lbs. / 2268Kg.
Max Capacity/ Rear Axle	5,000Lbs. / 2268Kg.	5,000Lbs. / 2268Kg.	5,000Lbs. / 2268Kg.	5,000Lbs. / 2268Kg.
A- Height Overall:	145" / 3683 mm. (*)	169" / 4293mm.	145" / 3683mm. (*)	169" / 4293mm.
B -Width Overall -NARROW CONFIGURATION	137" / 3480mm.	137" / 3480mm.	137" / 3480mm.	137" / 3480mm.
B -Width Overall -WIDE CONFIGURATION	145" / 3683mm.	145" / 3683mm.	145" / 3683mm.	145" / 3683mm.
D- Floor to Overhead Switch:	141" / 3581mm. (*)	165" / 4191mm.	141" / 3581mm. (*)	165" / 4191mm. (*)
F -Reach (Front Arm Min.):	23-1/2" / 597mm.	23-1/2" / 597mm.	23-1/2" / 597mm.	23-1/2" / 597mm.
G -Reach (Front Arm Max.):	45-1/2" / 1156mm.	45-1/2" / 1156mm.	38-1/2" / 978mm.	38-1/2" / 978mm.
H- Reach (Rear Arm Min.):	42-1/2" / 1079mm.	42-1/2" / 1079mm.	34-1/2" / 876mm.	34-1/2" / 876mm.
I- Reach (Rear Arm Max.):	60" / 1524mm.	60" / 1524mm.	54-1/2" / 1384mm.	54-1/2" / 1384mm.
J- Min. Pad Height:	4" / 102mm.	4" / 102mm.	4" / 102mm.	4" / 102mm.
Screw Pad Adjustment	2" / 51mm.	2" / 51mm.	2" / 51mm.	2" / 51mm.
K- Rise:	69" / 1753mm.	69" / 1753mm.	69" / 1753mm.	69" / 1753mm.
L -Max Lift Height (Pad Only):	73"-75" / 1854-1905mm.	73"-75" / 1854-1905mm.	73"-75" / 1854-1905mm.	73"-75" / 1854-1905mm.
M - Max Lift Height (6" Adapter):	75.5"-77.5" / 1917mm-1968	75.5"-77.5" / 1917mm-1968	75.5"-77.5" / 1917mm-1968	75.5"-77.5" / 1917mm-1968
Standard Motor(**)	220VAC / 60Hz.1Ph.	220VAC / 60Hz.1Ph.	220VAC / 60Hz.1Ph.	220VAC / 60Hz.1Ph.
Time of Full Rise:	45 Seconds	45 Seconds	45 Seconds	45 Seconds
Max Load Per Arm:	2,500Lbs. / 1134Kg.	2,500Lbs. / 1134Kg.	2,500Lbs. / 1134Kg.	2,500Lbs. / 1134Kg.
Emission sound pressure at Operator Position < 70 dB(A).				
* An optional bolt-on extension for column raises the overhead bar an additional 24". Must be ordered from factory at time of order.				
** Special Voltages Available Upon Request. The design, material and specifications are subject to change without notice.				
The design, material and specifications are subject to change without notice.				

CLEARANCES

XPR-10S

IMPORTANT NOTE:

The measurements shown below are for reference only. Your specific floorplan requirements may differ depending on bay size and vehicles being serviced.

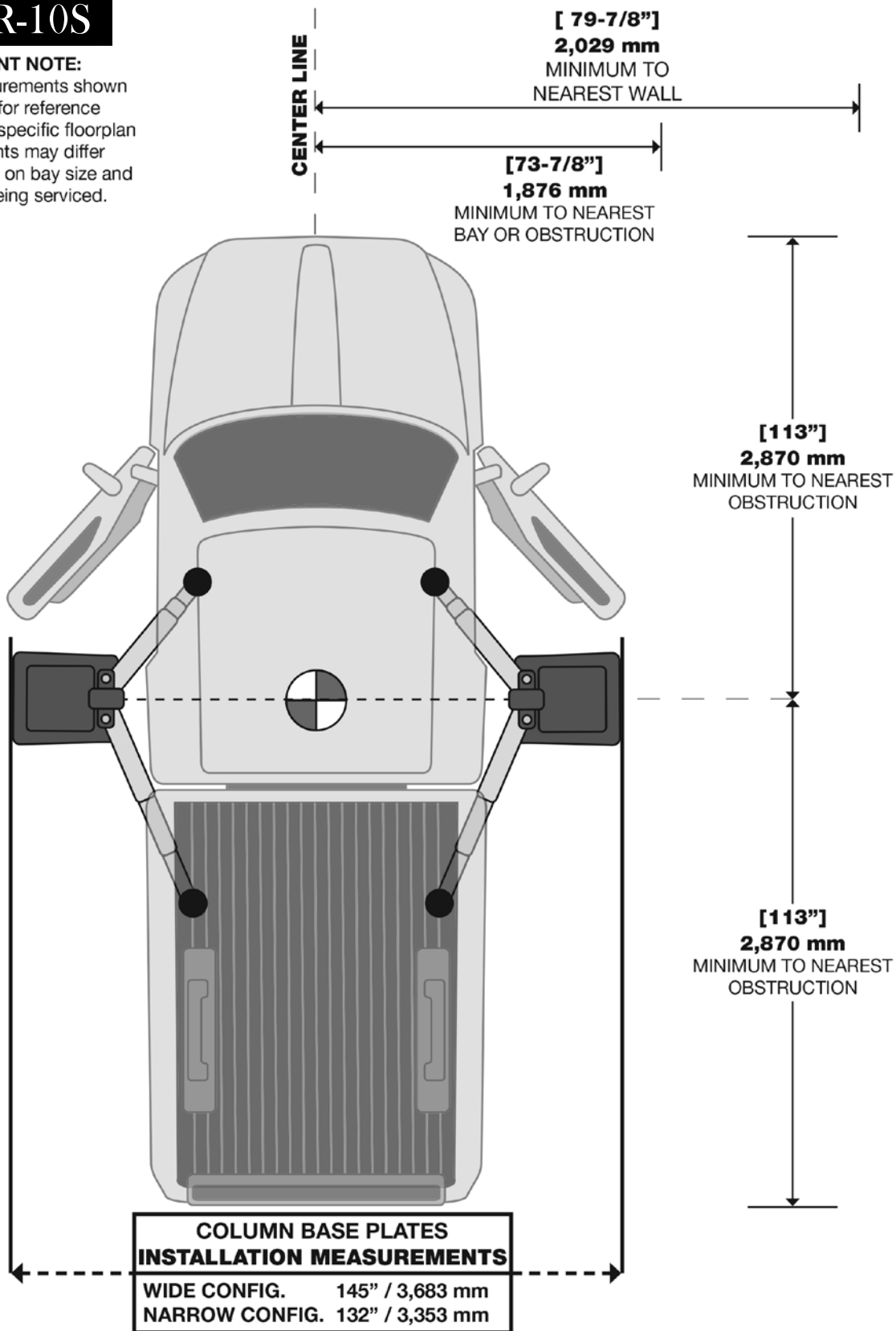

LIFT HEIGHT CLEARANCE NOTE: There must be a 1" MIN distance from top of lift to nearest obstruction.

CLEARANCES

XPR-10AS

IMPORTANT NOTE:

The measurements shown below are for reference only. Your specific floorplan requirements may differ depending on bay size and vehicles being serviced.

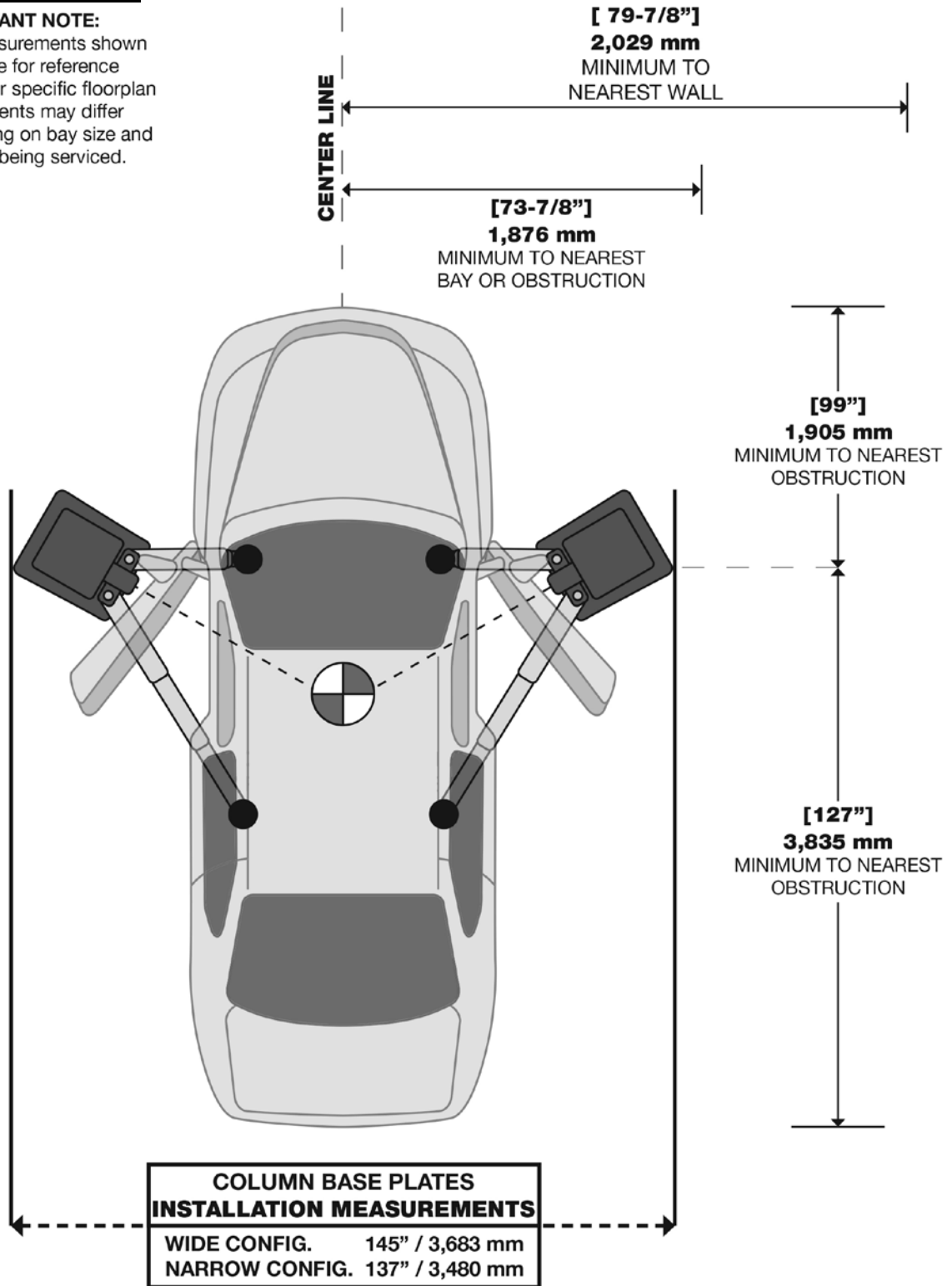

LIFT HEIGHT CLEARANCE NOTE: There must be a 1" MIN. distance from top of lift to nearest obstruction.

STEP 3
(Post Preparation)
 COMPLETE THE FOLLOWING
 PRIOR TO RAISING THE POSTS

NOTE:
 DETERMINE DESIRED LOCATION AND WIDTH
 LAYOUT BEFORE RAISING POSTS. REFER TO
 LAYOUT CHARTS ON PAGE 12.

1. Prior to raising posts, slide each carriage upwards to aid in sheave removal and equalizer cable routing.

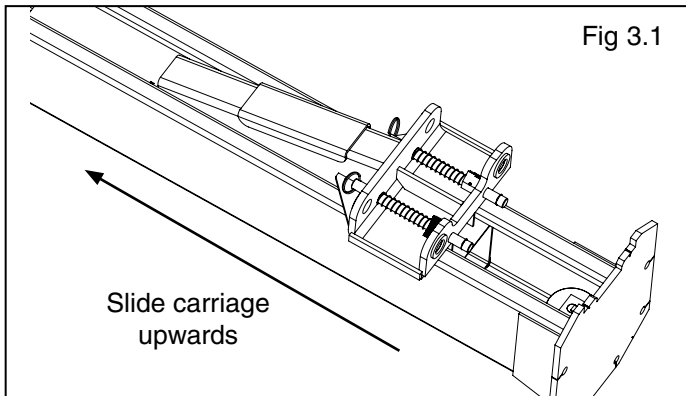

2. Remove the cable sheaves located at the inside bottom of each post.

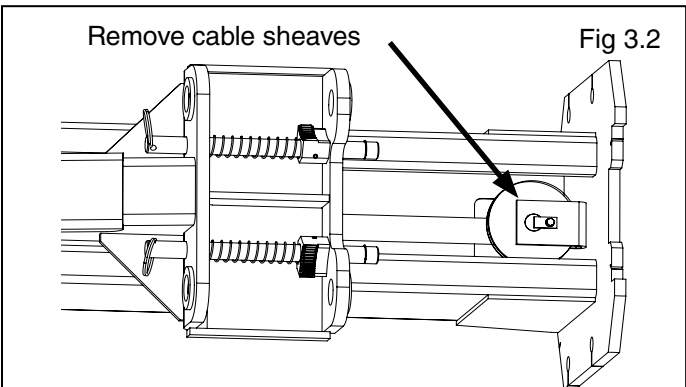

3. Identify the correct cable button on the end of each equalizer cable that corresponds to your desired lift configuration. Route the button around the bottom sheave and secure at the carriage lock plate located inside each carriage.

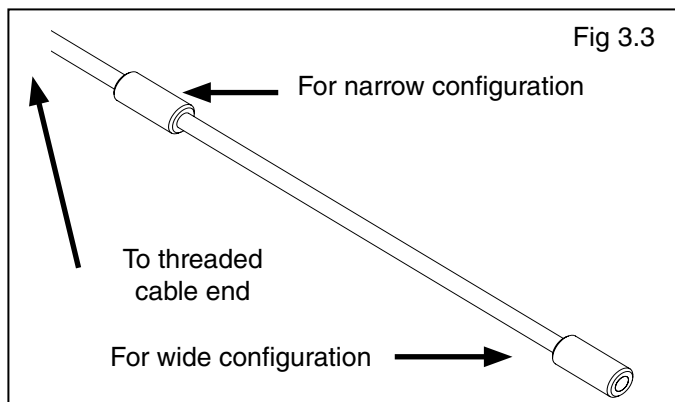

NOTE:
 SYMMETRICAL MODELS BOTH CABLES ARE SAME
 LENGTH. ASYMMETRIC MODELS HAVE TWO
 DIFFERENT LENGTH CABLES. (SEE FIG. 3.4)

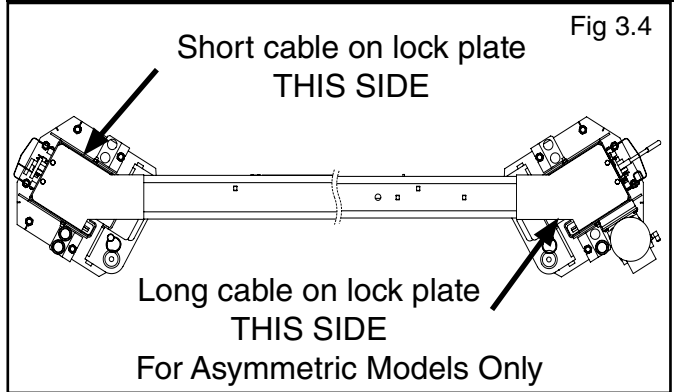

4. Route threaded end of cable upwards through the bottom of the carriage. Leave excess cable resting on top of carriage until further steps are required. (See Fig 3.5)

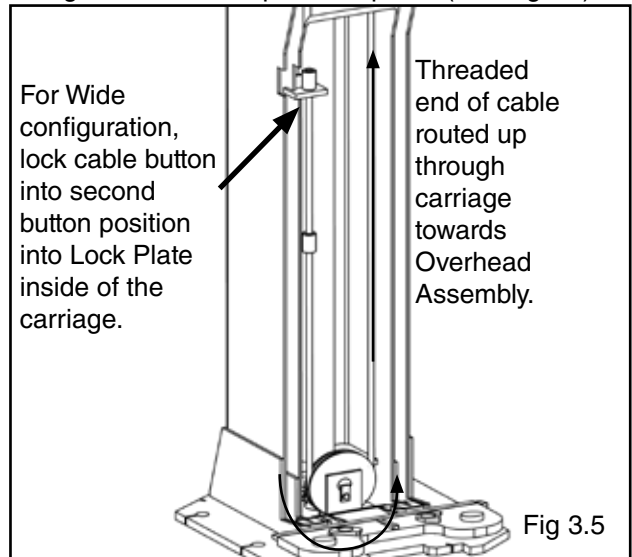

NOTE: Portions of Carriage and Post cut away for clarity

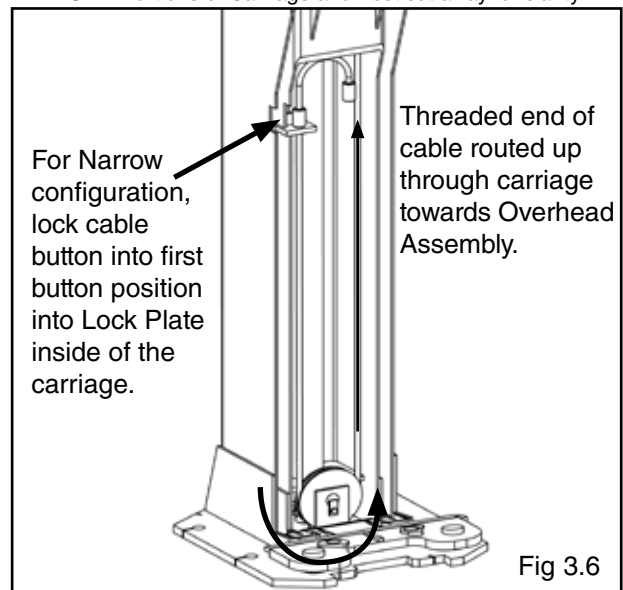

NOTE: Portions of Carriage and Post cut away for clarity
 NOTE: Second Cable Button should be tucked away from the lifting cable route. Second Cable Button in Fig 3.6 shown for representational purposes only.

5. Install the cylinder fittings in cylinder ports. Pay attention when installing the fittings to ensure that each fitting points towards the side of the post that the hose retainer clips are located on. (See Fig 3.7)

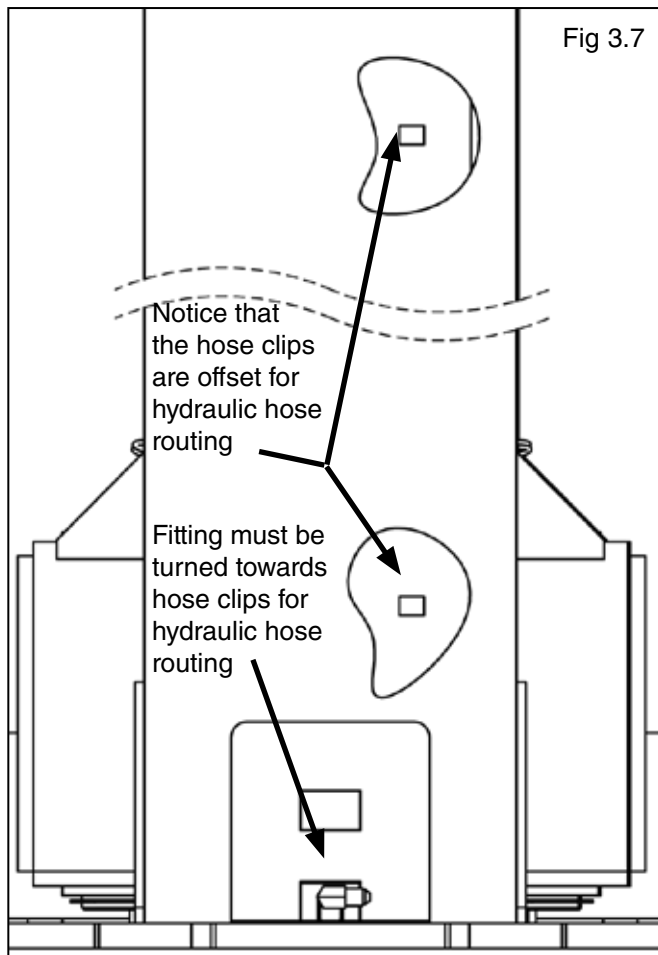

Fig 3.7

NOTE: Portions of Post cut away for clarity

6. Route both hoses in their respective posts **PRIOR** to raising posts to their vertical position. When routing the hydraulic hoses through the post, make sure to route through the hose clips welded inside each post. Make sure that the hoses are clear of any moving parts. It may be necessary to tie hoses clear of obstructions by using nylon tie straps or wire. Refer to Step 10 for further instructions.



BE SURE TO ROUTE THE HYDRAULIC HOSES THROUGH THE HOSE CLIPS WELDED INSIDE EACH POST.

NOTE FOR EXTENDED HEIGHT MODELS:
FOR XPR-10S-168, XPR-10AS-168, XPR-10TS-168, XPR-10S-168-LP, XPR-10AS-LP-168 MODELS, FIT EXTENSION WELDMENTS TO POST ASSEMBLY IN THIS STEP FOR EASE OF INSTALLATION AND BOLT TOGETHER AS SHOWN BELOW WITH M12 HARDWARE.

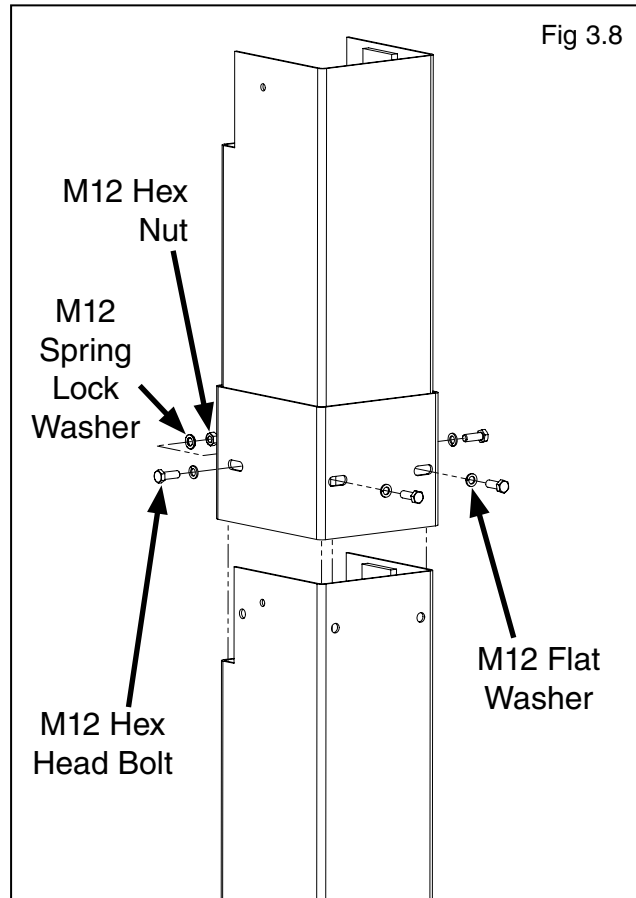

Fig 3.8



FOR TECHNICAL SUPPORT, PLEASE CALL:
 1-(800) 253-2363 Ext. 196

TO ORDER PARTS, PLEASE CALL:
 1-(800) 253-2363 Ext. 191

EQUALIZER CABLE ROUTING

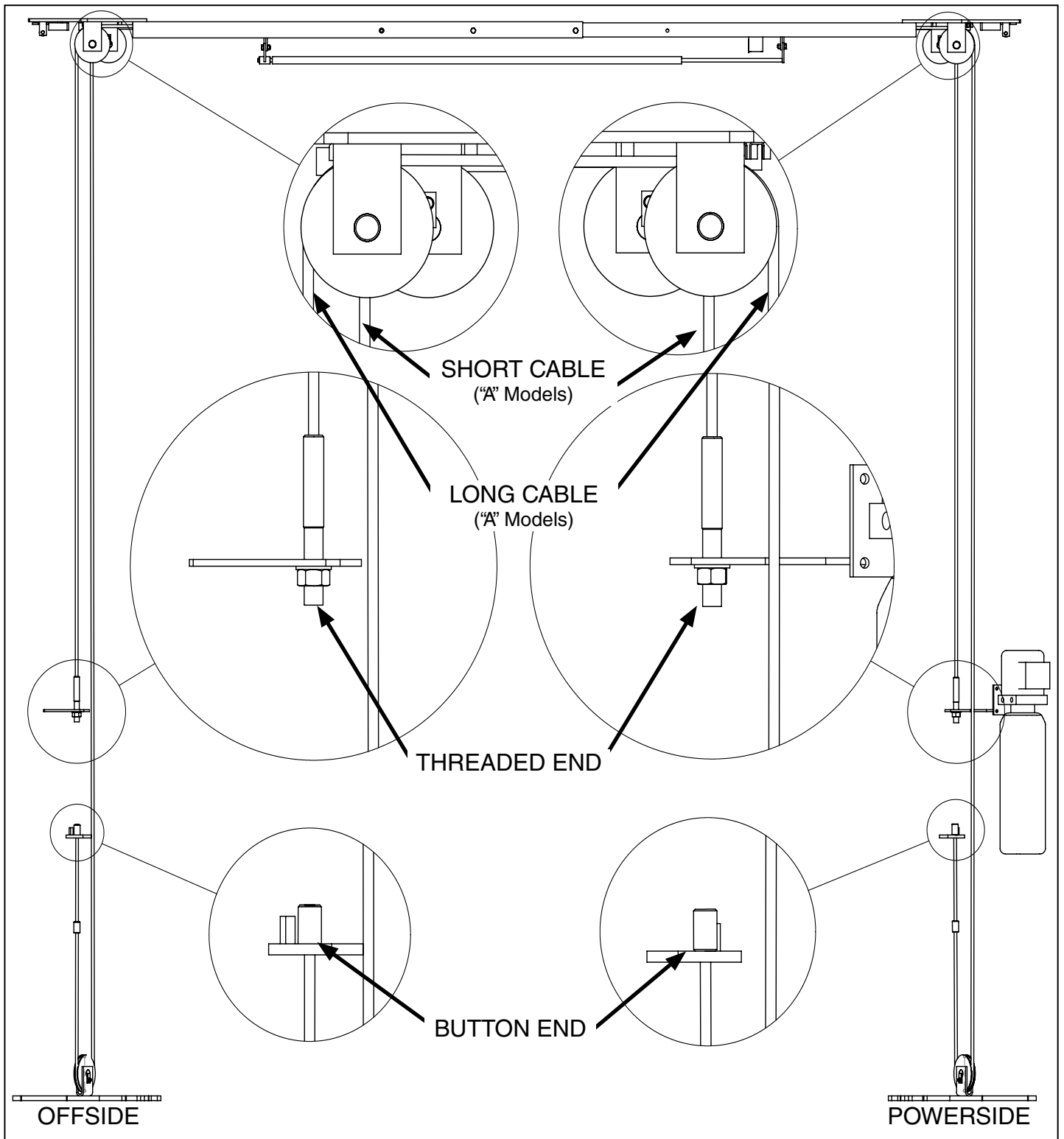

XPR-10AS wide configuration shown.

NOTE:

**XPR -10S models: both Equalizer Cables are the same length.
Overhead Assembly sheaves ARE NOT staggered.
XPR-10AS models: have one short and one long Equalizer Cable.
Overhead Assembly sheaves ARE staggered.**

HOSE ROUTING

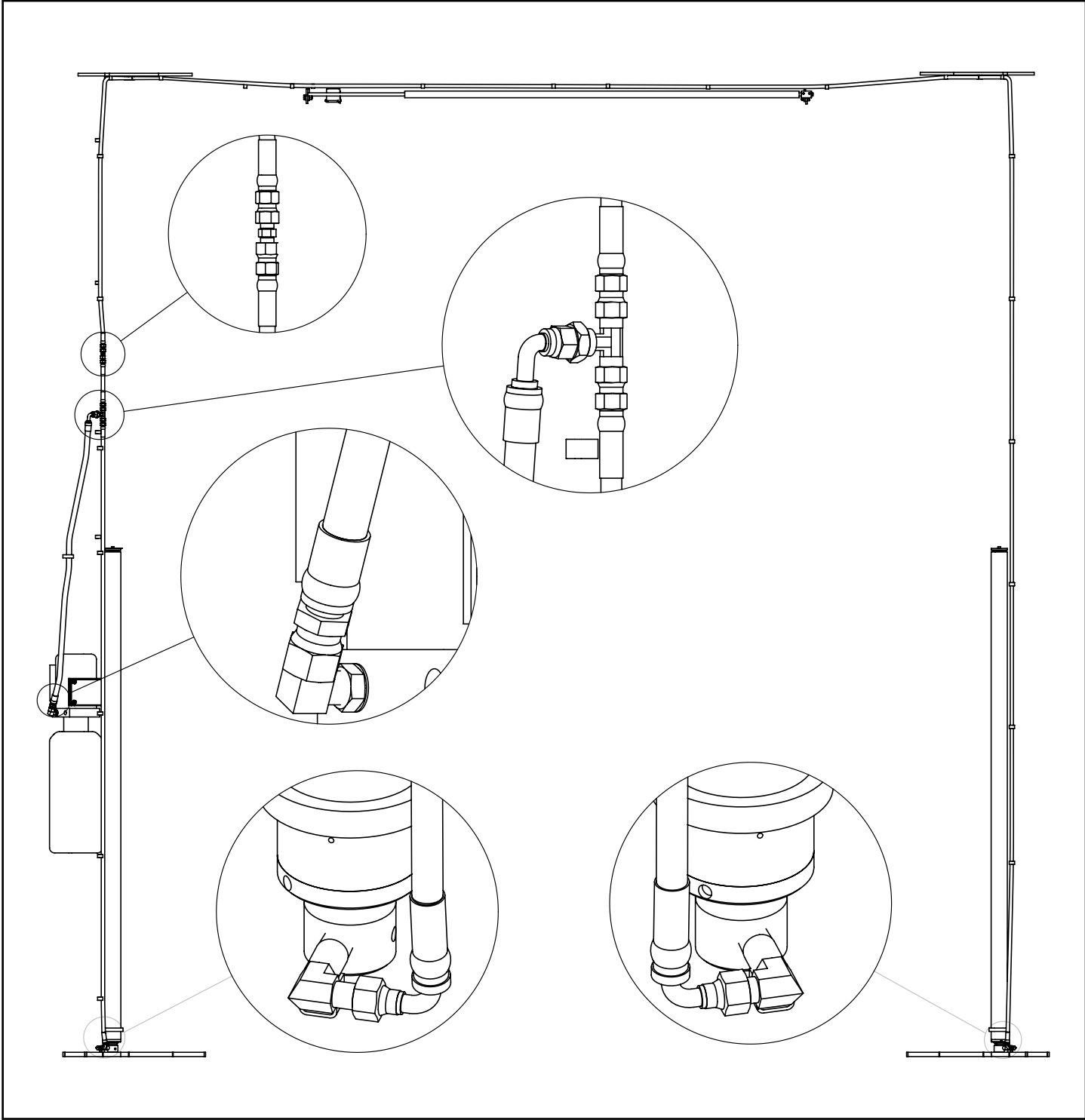
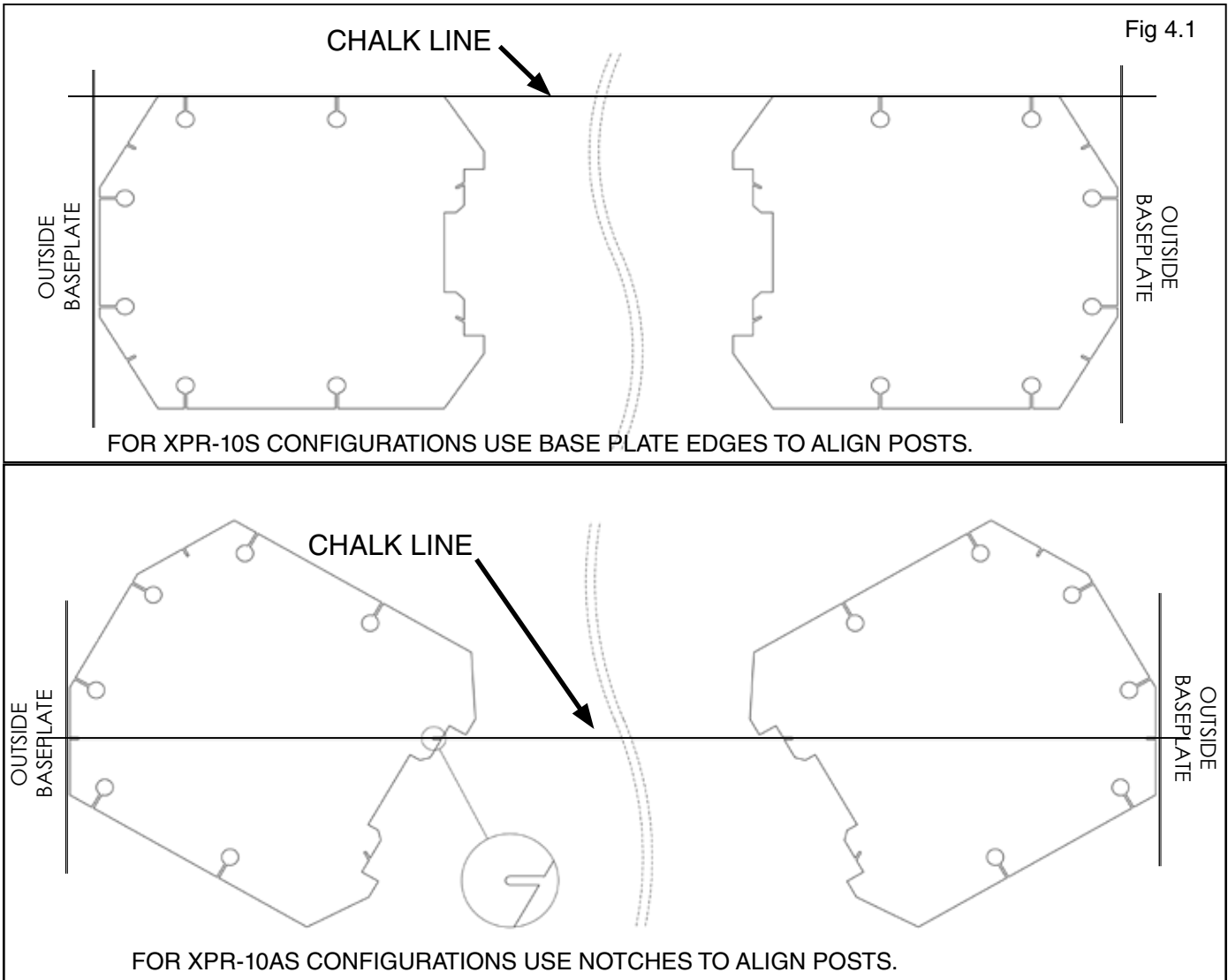

Fig 4.1



STEP 4 (Site Layout)

1. Determine which side of the lift will be the approach side.
2. Now determine where the power unit will be located. The POWER SIDE column has the power unit mounting bracket attached to the side.
3. Use the chart on page 12 to determine which lift width layout you would like to use. Also, you can see image above for reference.
4. Once a location is determined, use a carpenter's chalk line to layout an alignment line for the post locations. Keep all dimensions square within 1/8" (3mm) or malfunction of the lift can occur. (See Fig 4.1)
5. After the post locations are properly marked, use chalk or crayon to make an outline of the posts on the floor at each post location using the post base plates as a template.
6. **CHECK ALL DIMENSIONS TWICE** and make sure that the layout is perfectly square.

STEP 5 (Installing the POWER SIDE post)

NOTE:
 BENDPAK LIFTS ARE SUPPLIED WITH INSTALLATION INSTRUCTIONS AND CONCRETE FASTENERS MEETING THE CRITERIA AS PRESCRIBED BY THE AMERICAN NATIONAL STANDARD "AUTOMOTIVE LIFTS - SAFETY REQUIREMENTS FOR CONSTRUCTION, TESTING, AND VALIDATION" ANSI/ALI ALCTV-2011. LIFT BUYERS ARE RESPONSIBLE FOR ANY SPECIAL REGIONAL STRUCTURAL AND/OR SEISMIC ANCHORING REQUIREMENTS SPECIFIED BY ANY OTHER AGENCIES AND/OR CODES SUCH AS THE UNIFORM BUILDING CODE (UBC) AND/OR INTERNATIONAL BUILDING CODE (IBC).

1. Before proceeding, double check measurements and make certain that the base plate of each post is aligned with the chalk line.

2. Using the baseplate on the POWER SIDE post as a guide, drill each anchor hole in the concrete approximately 4" deep for 10K models using a rotary hammer drill and 3/4" concrete drill-bit. To ensure full holding power, do not ream the hole or allow the drill to wobble. (See Fig. 5.1)

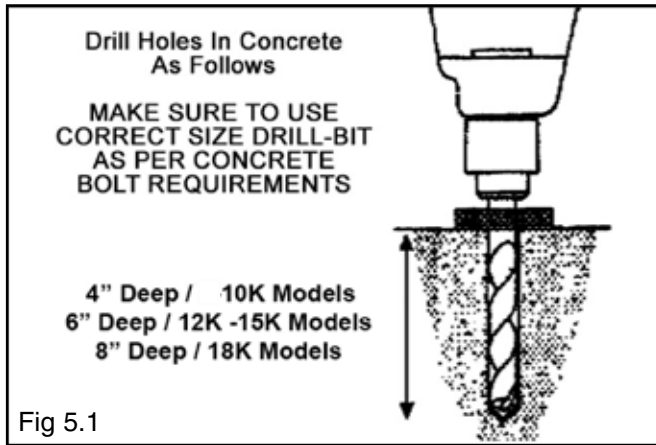

3. After drilling, remove dust thoroughly from each hole making certain that the posts remain aligned with the chalk line.

4. Assemble the washers and nuts on the anchors then tap into each hole with a hammer until the washer rests against the base plate. If shimming is required, be sure that enough threads are left exposed. (See Fig. 5.2)

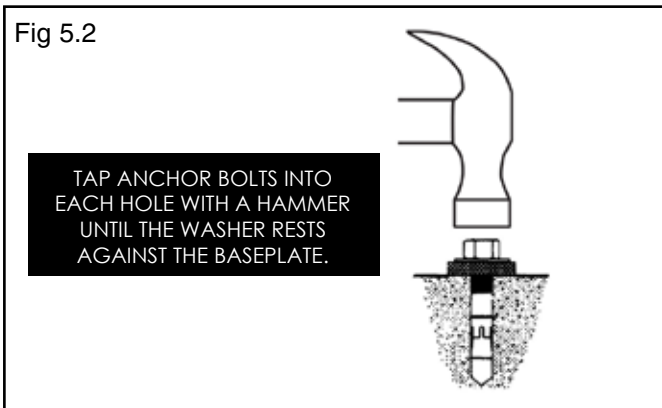

5. If shimming is required, insert the shims as necessary under the base plate so that when the anchor bolts are tightened, the posts will be plumb. (See Fig. 5.3)

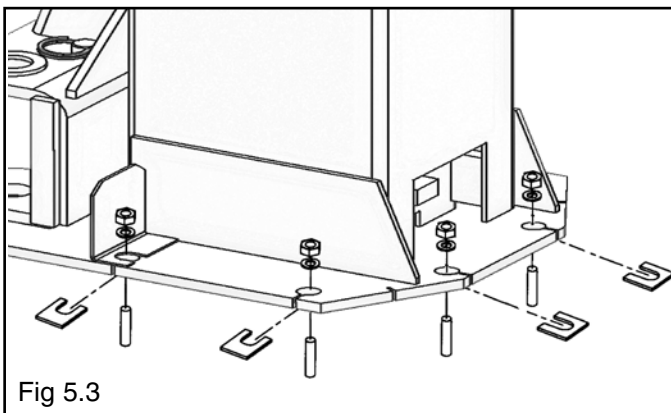

6. If installing the optional foot guards, place foot guards on left and right side as shown. (See Fig 5.4)

NOTE:
TO EASE INSTALLATION OF THE OVERHEAD ASSEMBLY, IT HELPS TO KEEP THE ANCHOR BOLTS LOOSE ON ONE OF THE POSTS UNTIL THE OVERHEAD ASSEMBLY IS MOUNTED.

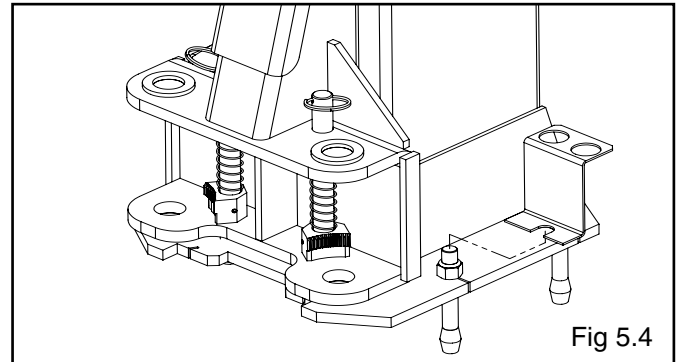

7. With the foot guards, shims and anchor bolts in place, tighten by securing the nut to the base then turning 3-5 full turns clockwise. **DO NOT** use an impact wrench for this procedure. (See Fig. 5.5)

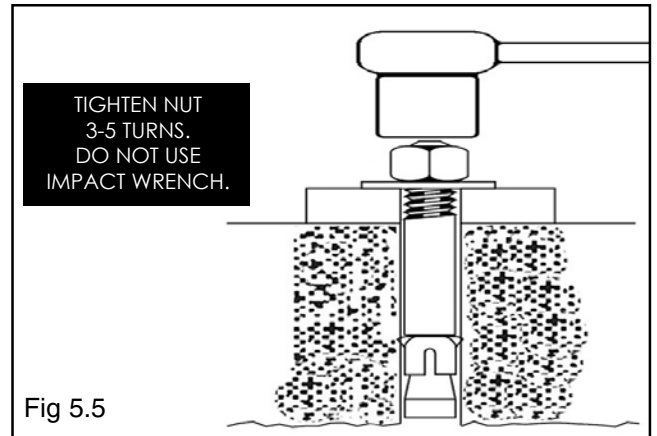

STEP 6
(Installing the OFF SIDE post)

1. Position the OFF SIDE post at the designated chalk locations and secure post to the floor following the same procedures as outlined in STEP 5: Paragraphs 1-6.

NOTE:
TO EASE THE INSTALLATION OF THE OVERHEAD ASSEMBLY, IT HELPS TO KEEP THE ANCHOR BOLTS LOOSE ON ONE OF THE POSTS UNTIL THE OVERHEAD ASSEMBLY IS MOUNTED.

STEP 7
(Mounting the Overhead Assembly)

1. Remove all of the equalizer cable sheaves in preparation for the installation of the Overhead Assembly.

NOTE:
IN ORDER TO ROUTE THE EQUALIZER CABLES THE SHEAVES MUST BE REMOVED.

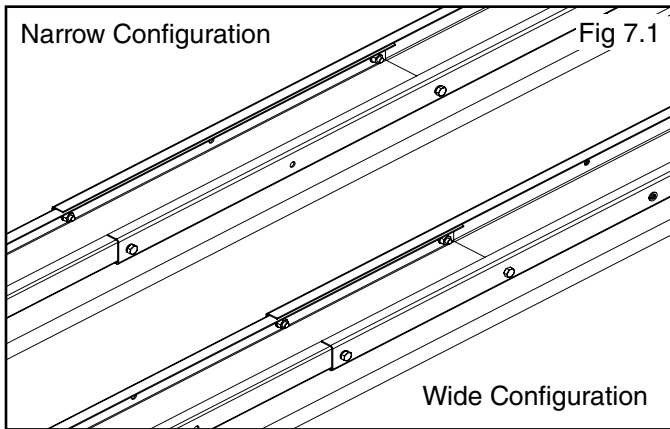

2. Adjust the Overhead Assembly width to match either the Narrow or Wide configuration, and loosely tighten bolts. (See Fig 7.1)

3. Using a lifting device, raise the Overhead Assembly into position on top of the posts. Bolt Overhead Assembly to the posts using the provided M10 hex head bolts, nuts and washers.

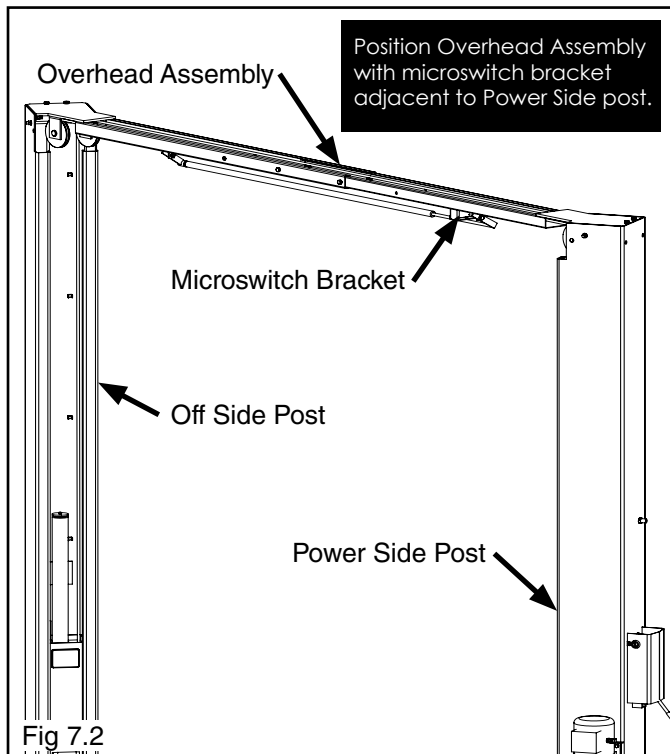

4. **YOU MUST** POSITION THE SWITCH ENCLOSURE ADJACENT TO POWER SIDE POST. (See Fig. 7.2)

5. Tighten the Overhead Assembly bolts.



IF THE ANCHOR BOLTS WERE LOOSENEED TO AID ON THE INSTALLATION OF THE TOP TROUGH, TIGHTEN ANCHOR BOLTS AS INDICATED IN STEP 5 ITEMS 4 - 7.

STEP 8 (Mounting the Hydraulic Power Unit)

1. Attach the power unit to the POWER SIDE post. Install the vibration dampener between the power unit and the power unit mounting plate on the Power Side post, using four M8 hex head bolts and nuts supplied. (See Fig 8.1)

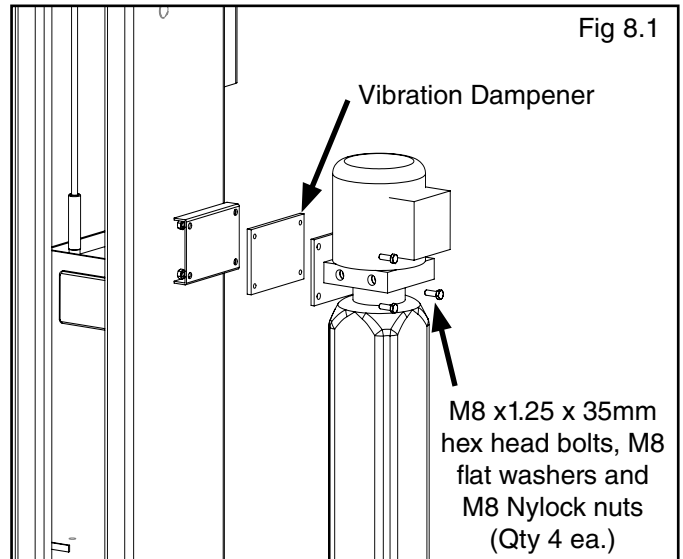

2. Fill the reservoir with 10 WT. HYDRAULIC OR APPROVED ATF FLUIDS SUCH AS DEXRON III, DEXRON VI, MERCON V, OR MERCON LV (another option ISO-32 grade) approximately four gallons. Make sure the funnel used to fill the Power Unit is clean. Do not connect power unit hydraulic hose assembly at this time.

3. The standard power unit for your lift is 220 volt, 60HZ, single phase. All wiring must be performed by a certified electrician only. SEE WIRING INSTRUCTIONS AFFIXED TO MOTOR FOR PROPER WIRING INFORMATION.

STEP 9 (Installing the Safeties and Safety Cable)



DO NOT PERFORM ANY MAINTENANCE OR INSTALLATION OF ANY COMPONENTS WITHOUT FIRST ENSURING THAT ELECTRICAL POWER HAS BEEN DISCONNECTED AT THE SOURCE OR PANEL AND CANNOT BE RE-ENERGIZED UNTIL ALL MAINTENANCE AND/OR INSTALLATION PROCEDURES ARE COMPLETED.

⚠ WARNING

DO NOT RUN POWER UNIT WITHOUT OIL. DAMAGE TO POWER UNIT PUMP CAN OCCUR.
 THE POWER UNIT MUST BE KEPT DRY. DAMAGE TO POWER UNIT CAUSED BY WATER OR OTHER LIQUIDS SUCH AS DETERGENTS, ACID ETC., IS NOT COVERED UNDER WARRANTY.
 OPERATE LIFT ONLY BETWEEN TEMPERATURES OF 41 ° - 104° F.

ANY IMPROPER ELECTRICAL INSTALLATION MAY DAMAGE POWER UNIT MOTOR AND RESULTING DAMAGE WILL NOT BE COVERED UNDER WARRANTY.
 MOTOR CAN NOT RUN ON 50HZ WITHOUT A PHYSICAL CHANGE IN MOTOR.

USE A SEPARATE CIRCUIT BREAKER FOR EACH POWER UNIT.
 PROTECT EACH CIRCUIT WITH TIME DELAY FUSE OR CIRCUIT BREAKER.

FOR 208-230 VOLT, SINGLE PHASE, USE A 25 AMP FUSE.

FOR 208-230 VOLT, THREE PHASE, USE A 20 AMP FUSE.

FOR 380-440 VOLT, THREE PHASE, USE A 15 AMP FUSE.

1. Install safety weldments onto each respective post.
(See Figs 9.1 - 9.2)
2. From the Off Side post insert the non-looped end of the safety cable through the hole located to the right of the Off Side safety weldment. (See Fig 9.3)

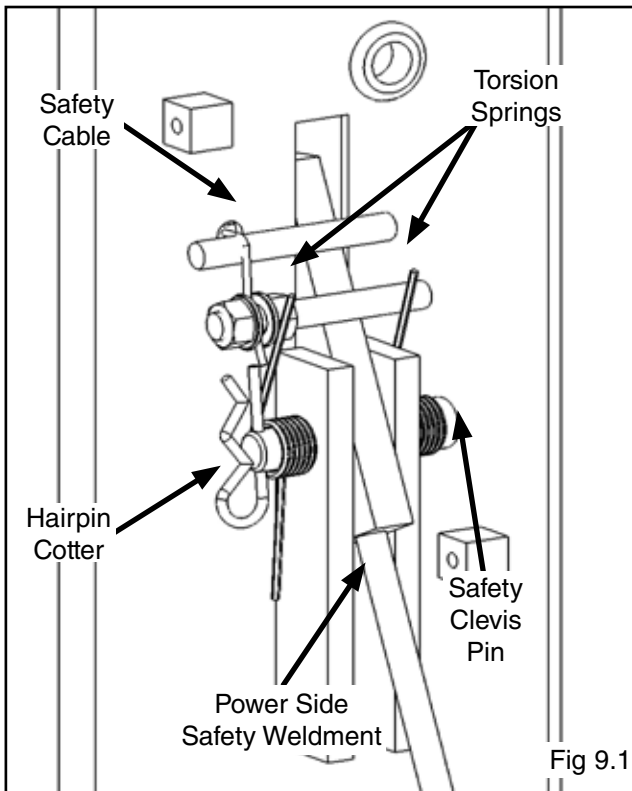

3. Route the cable under the sheave and route it towards the Overhead Assembly. (See Fig 9.4)
4. Route the cable through the Overhead Assembly's safety sheave(s) and across the lift. (See Figs 9.5 - 9.6)

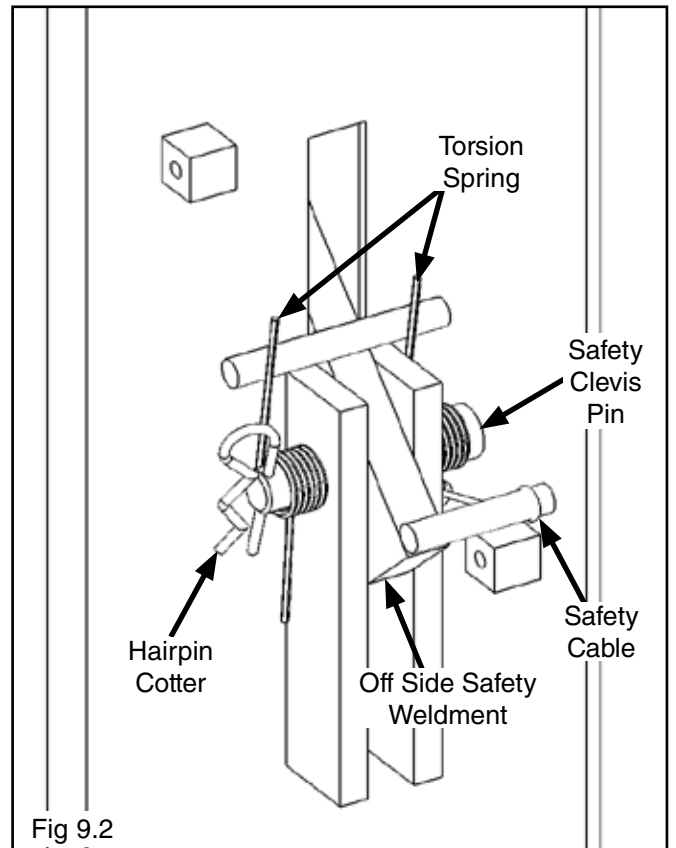

5. Route the cable the same way on the Power Side going back down the post.
6. Route the cable over the top pin on the safety handle. Insert the cable end through the hole on the threaded pin. (See Fig 9.7)
7. Pull the slack out the safety cable and keep tension on the cable as nuts are being tightened. Tighten jam nuts on either side of the cable keeping the cable centered to the hole to secure it into place. (See Fig 9.7)

! DANGER

ENSURE THAT BOTH THE POWER SIDE & OFF SIDE SAFETIES ENGAGE PROPERLY PRIOR TO LIFT OPERATION.

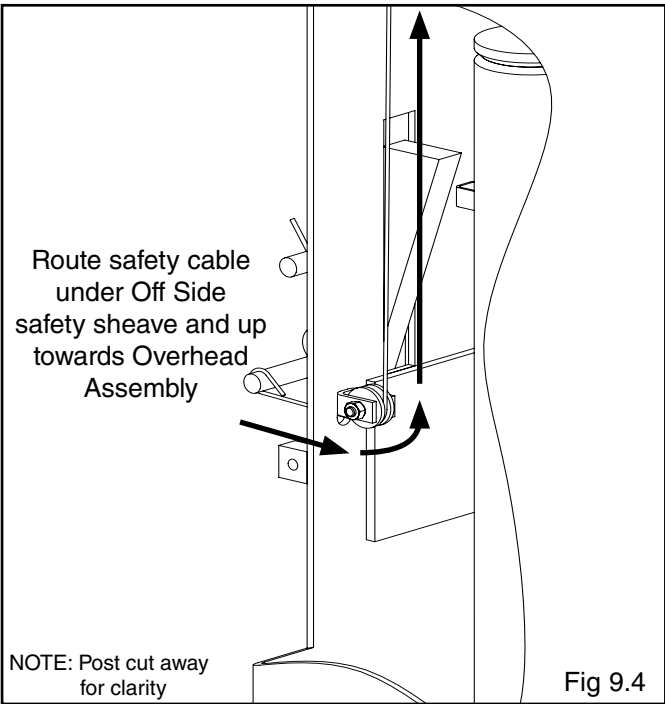
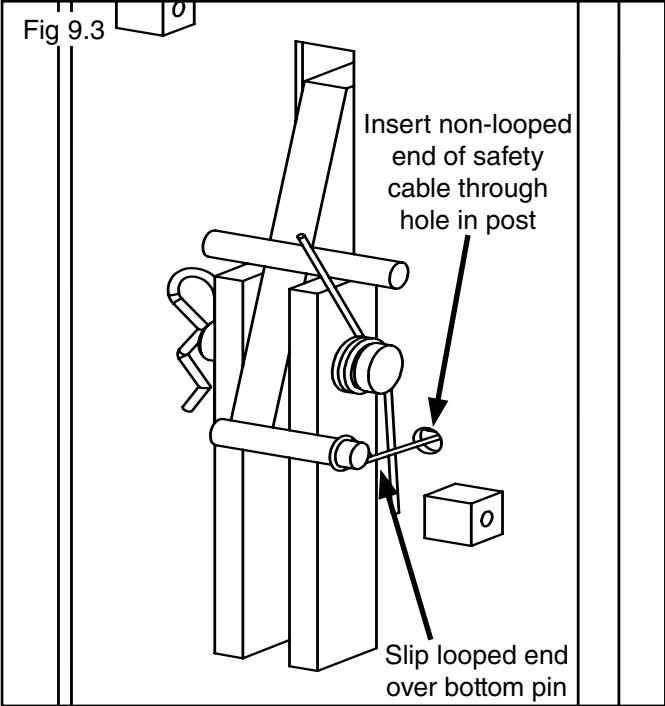

NOTE:
MAKE SURE TO KEEP THE SAFETY CABLE CENTERED WHEN TIGHTENING JAM NUTS ON SAFETY.

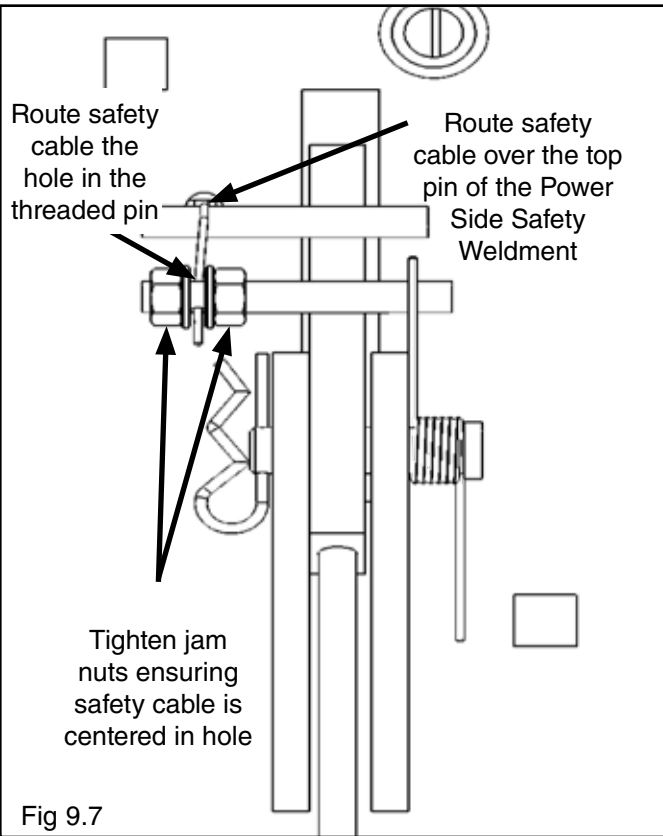
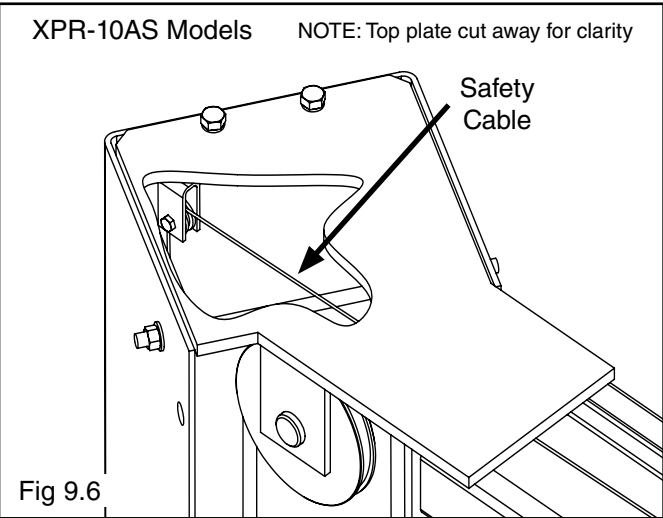
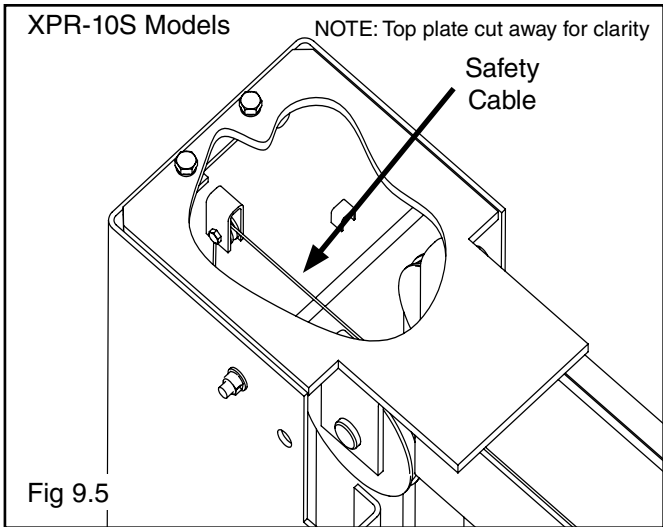

STEP 10 (Installing Hydraulic Lines)

FOR WIDE CONFIGURATION, A 13" EXTENSION FOR SYMMETRIC MODELS OR AN 8" EXTENSION FOR ASYMMETRIC, MUST BE INSTALLED TO THE CROSSOVER HOSE. A JIC TO JIC STRAIGHT FITTING HAS BEEN PROVIDED TO CONNECT THE CROSSOVER HOSE TO THE EXTENSION HOSE IN THE PARTS BOX. (See Fig. 10.1 A)

1. Install the bulkhead tee fitting into the Power Side post. The through hole is located approximately 90 inches from the floor on the back wall of the Power Side post.

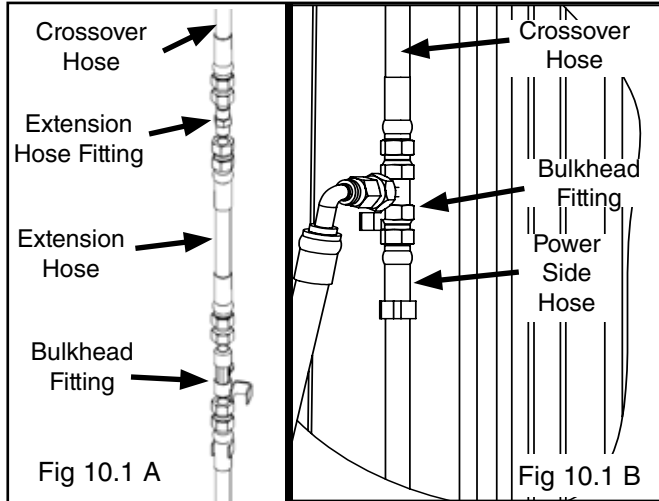

2. Connect the **Power Side** cylinder hose to the tee fitting. Be sure to route the hose through the retainer clips inside the posts.



WHEN ROUTING THE HYDRAULIC HOSE THROUGH THE POSTS, MAKE SURE TO ROUTE THROUGH THE HOSE CLIPS WELDED INSIDE EACH POST. MAKE SURE THAT THE HOSE IS CLEAR OF ANY MOVING PARTS. IT MAY BE NECESSARY TO TIE THE HOSE CLEAR BY USING NYLON TIE STRAPS OR WIRE.

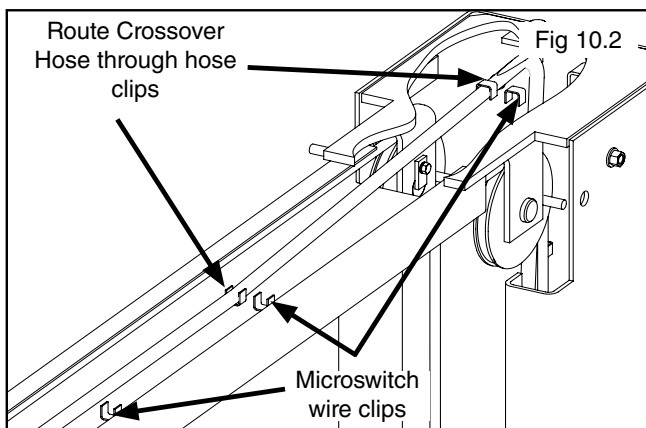

3. Route the Off Side cylinder hose (Crossover Hose) up through the post and across the Overhead Assembly, down the post and connect it to the bulkhead tee fitting. (See Fig 10.1 and Fig 10.2)



WHEN THE CABLE ADJUSTING NUTS BOTTOM OUT ON THE THREADED END OF THE CABLE CONNECTOR AND THERE IS STILL SLACK IN THE CABLES, THE CABLES HAVE STRETCHED BEYOND THE SAFE USEFUL LENGTH AND NEED TO BE REPLACED WITH FACTORY APPROVED CABLE ASSEMBLIES. DO NOT PLACE WASHERS, SPACERS OR OTHER DEVICES TO "SHORTEN" THE EFFECTIVE CABLE LENGTH AS DAMAGE TO THE LIFT OR INJURY TO PERSONS MAY OCCUR.

STEP 11 (Routing the Equalizer Cables)

Refer to illustrations on Page 15.

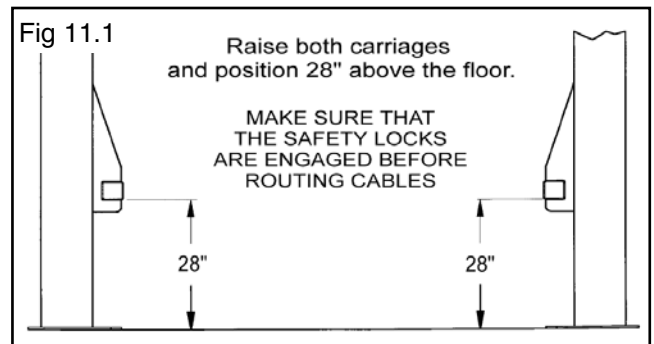

MAKE SURE THAT THE SAFETY LOCKS ON EACH POST ARE FULLY ENGAGED BEFORE ATTEMPTING TO ROUTE EQUALIZER CABLES AND/OR HOSES. CARRIAGES MUST BE EQUAL HEIGHT FROM THE FLOOR BEFORE PROCEEDING.

1. Raise and lock each Carriage approximately 28" above the ground. (See Fig. 11.1)
2. With the Carriages locked at 28" off the floor, route the Equalizer Cables up to the Top Trough.
3. Route the cables through the sheave brackets and reinstall the sheaves. (See Fig. 11.2)

Note: The sheaves should have been removed in Step 6.

4. Insert the threaded end of the cable through the hole on top of the carriage. Place M18 washer and M18 Nylock nut on threaded cable end. Tighten cable nuts

until taut, checking that both cables have equal tension. (See Fig 11.3)

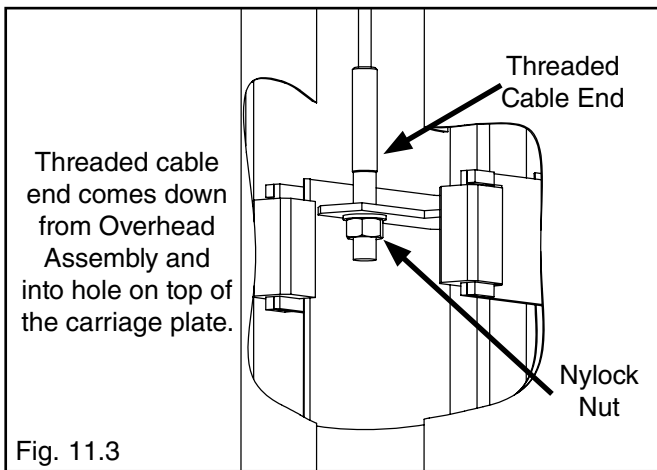
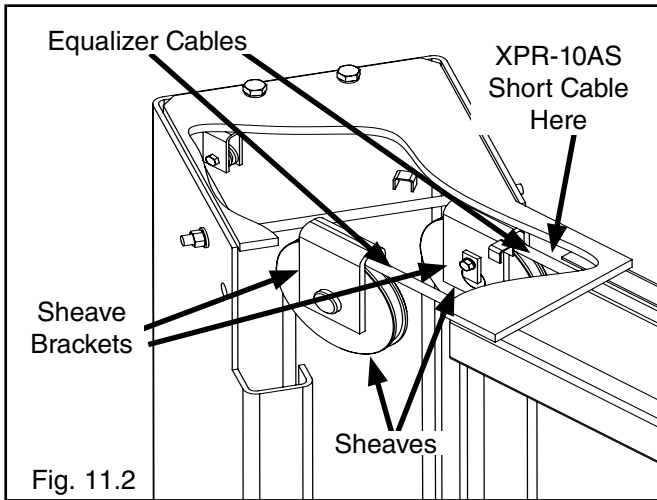

! DANGER

ALL WIRING MUST BE PERFORMED BY A LICENSED ELECTRICIAN.

! DANGER



DO NOT PERFORM ANY MAINTENANCE OR INSTALLATION OF ANY COMPONENTS WITHOUT FIRST ENSURING THAT ELECTRICAL POWER HAS BEEN DISCONNECTED AT THE SOURCE OR AT POWER PANEL AND CANNOT BE RE-ENERGIZED UNTIL ALL MAINTENANCE AND/OR INSTALLATION PROCEDURES ARE COMPLETED.

STEP 12 (Installing Overhead Microswitch)

! CAUTION

MICROSWITCH WIRE MUST BE RUN THROUGH CLIPS IN POST AND OVERHEAD ASSEMBLY. FAILURE TO DO SO CAN CAUSE DAMAGE TO LIFT OR TO VEHICLES.

1. Install the overhead Microswitch as shown below. Be sure to keep wire clear of moving parts. (See Fig.12.1)

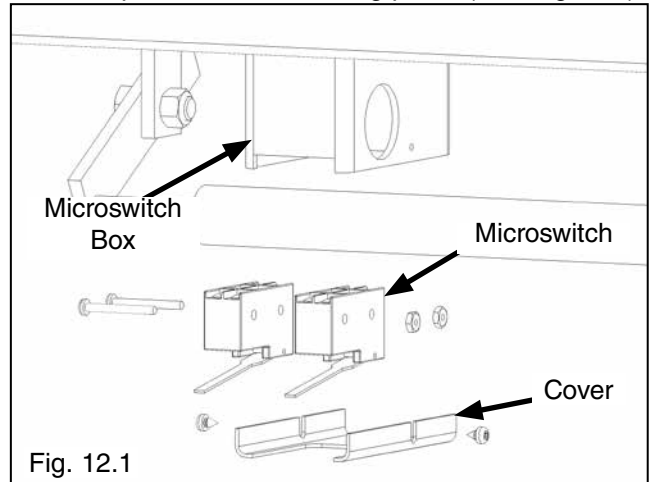

Note: Second Microswitch for 3 phase wired units ONLY. 3 phase Microswitch Kit can be found in the Power Unit shipping box.

2. Route Microswitch wire through the hole in Power Side post with a rubber grommet. Loosely position Power Side safety cover and run other end of Microswitch wire through hole with grommet in Power Side safety cover. (See Fig. 12.2)

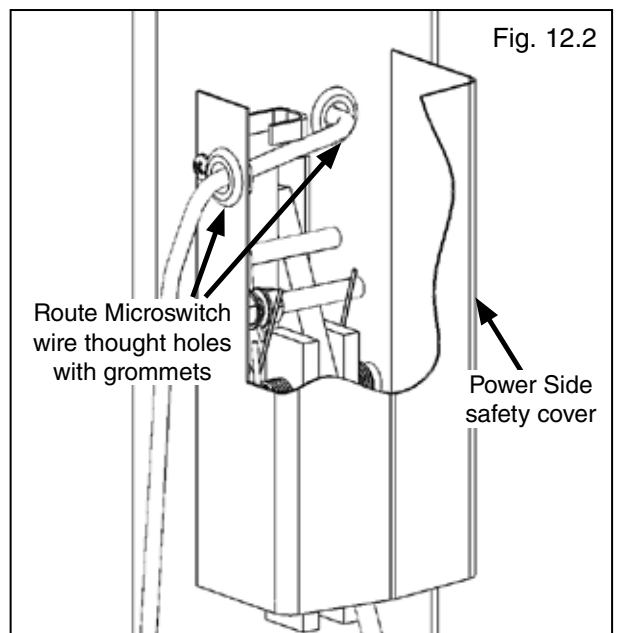

3. Route wire up through post and across Overhead Assembly through hole in Overhead Assembly into the Microswitch box. (See Fig. 12.3)

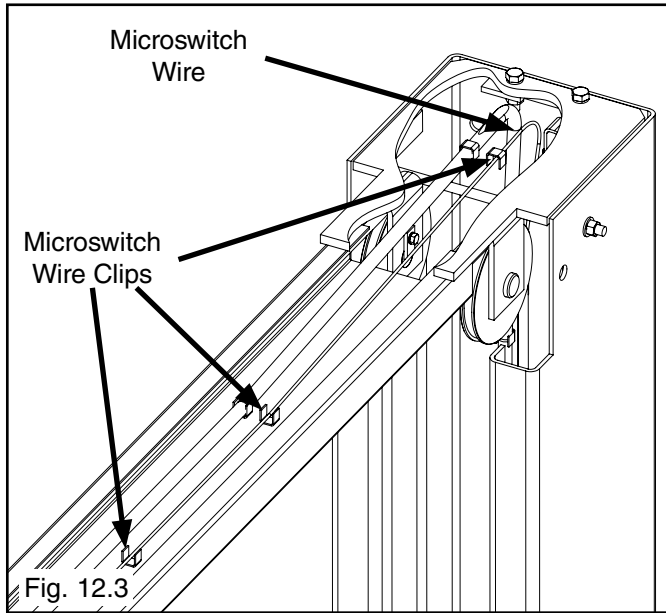

2. Install the 90° fitting w/ O-ring into the power port of the power unit. Use Teflon tape on the pipe fittings ONLY. Connect power unit hose assembly to the 90° w/O-ring fitting on the power unit. (See Fig. 13.2)

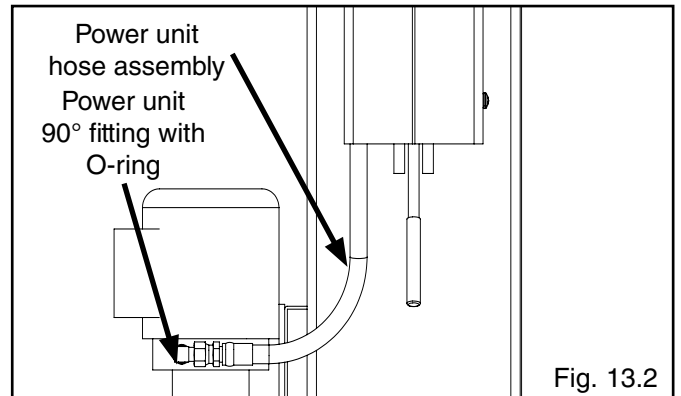

3. Connect other end of power unit hydraulic hose assembly to the bulkhead fitting. (See Fig. 13.3)

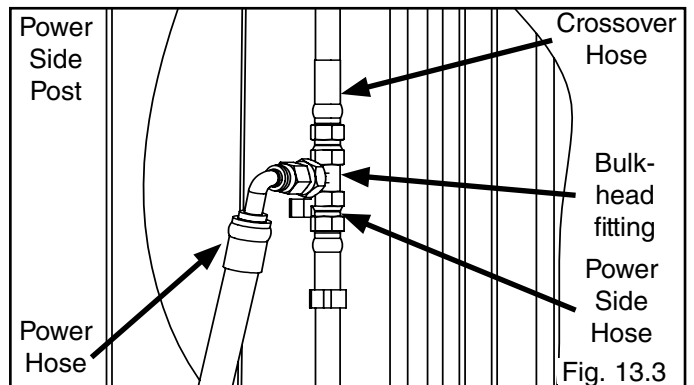

4. After safeties have been adjusted and checked for proper operation, install and tighten Power Side safety cover and Off Side safety cover mounting bolts. (See Fig. 13.4 and 13.5)

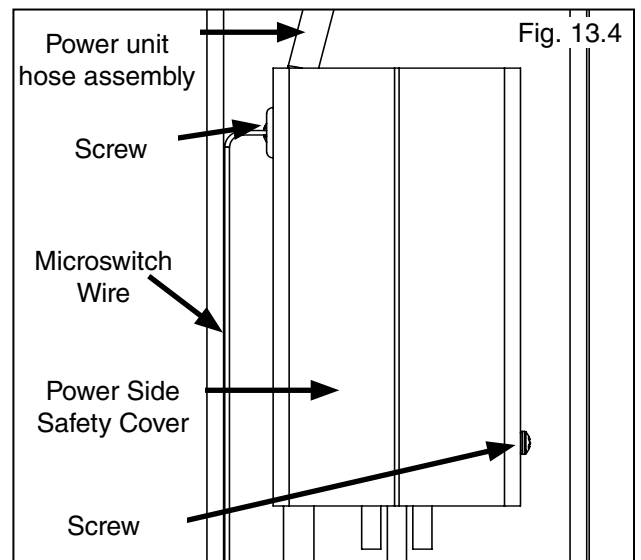

**STEP 13
(Installing Power Unit Hose Assembly
and Power Side Safety Cover)**



POWER UNIT HYDRAULIC HOSE MUST BE ROUTED THROUGH THE HOSE CLIPS IN POWER SIDE SAFETY COVER. FAILURE TO DO SO CAN RESULT IN PERSONAL INJURY OR DAMAGE TO THE LIFT.

1. With Power Side safety cover loosely positioned, route power unit hydraulic hose through clips in Power Side safety cover. (See Fig. 13.1)

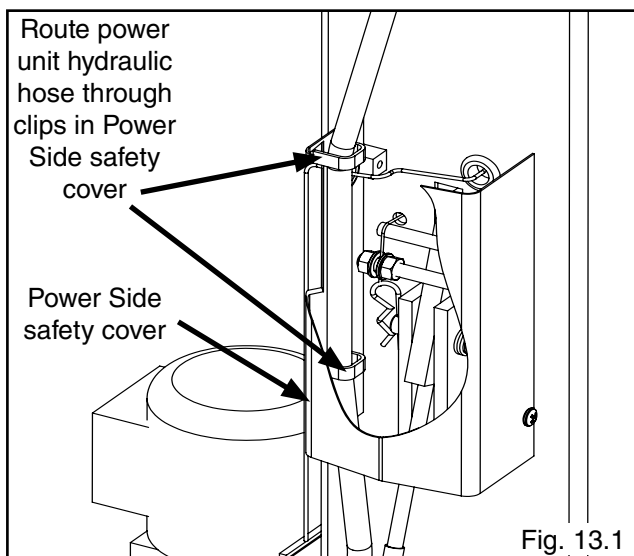

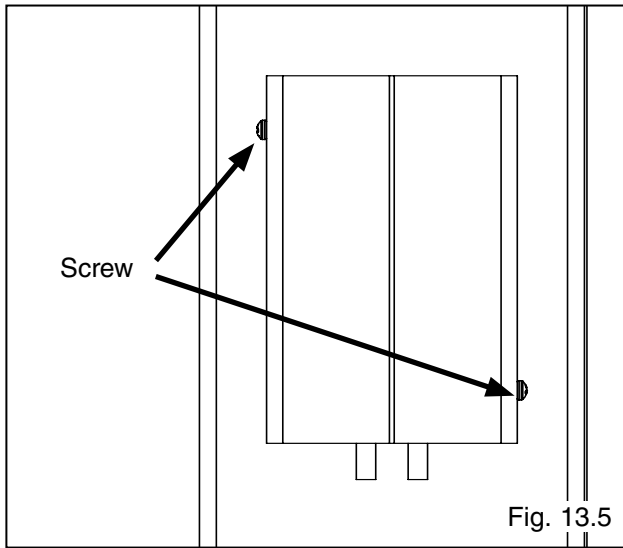

**STEP 14
(Installing the Lift Arms)**

1. Place the appropriate lift arm assembly in the lift heads. (See Fig. 14.7 - 14.8)
2. Install the lift head pins into the lift head and through the holes in the arm assembly. (See Fig. 14.1)

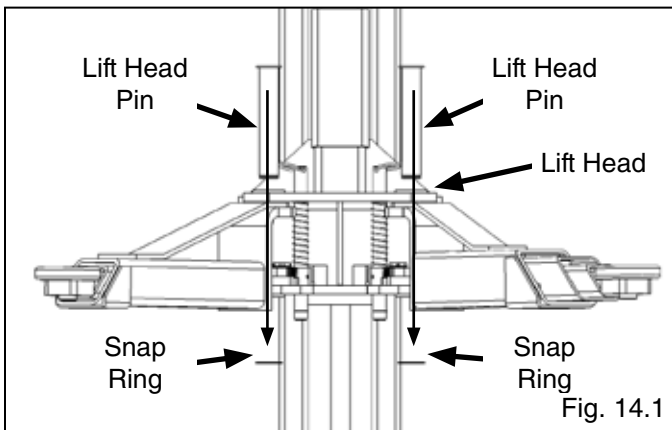

3. Install the snap ring into the groove in the lift head pin on under side of the lift head. (See Fig. 14.2)

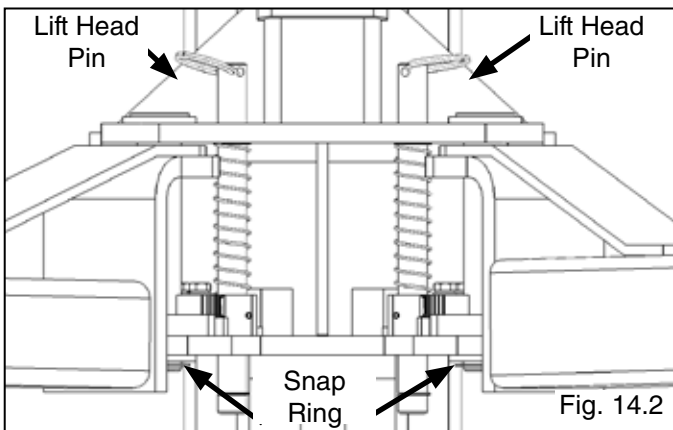

4. Each arm restraint gear can be oriented in a Left or Right configuration on the arms. Each arm and arm restraint gear must be positioned in the proper location in the lift head. (See Fig. 14.3 - 14.4)

! DANGER

THE ARM RESTRAINT GEARS MUST BE POSITIONED PROPERLY. CONFIRMATION OF PROPER GEAR ENGAGEMENT MUST BE MADE PRIOR TO THE OPERATION OF THE LIFT. PERIODIC INSPECTION IS REQUIRED. FAILURE TO INSPECT THE ARM RESTRAINT GEARS ON ALL FOUR ARMS PROPERLY CAN RESULT IN DAMAGE TO THE VEHICLE OR INJURY AND/OR DEATH.

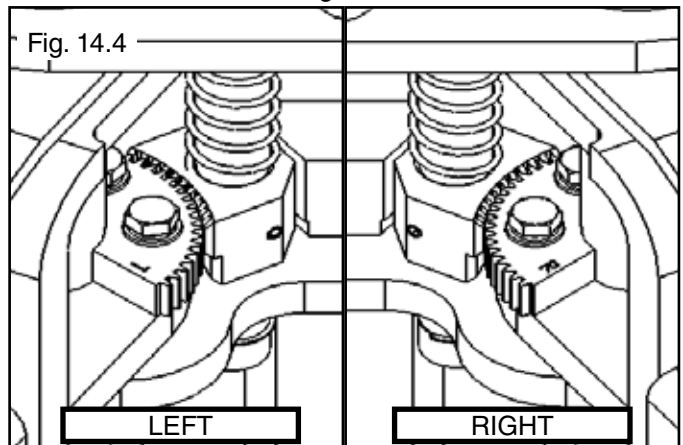
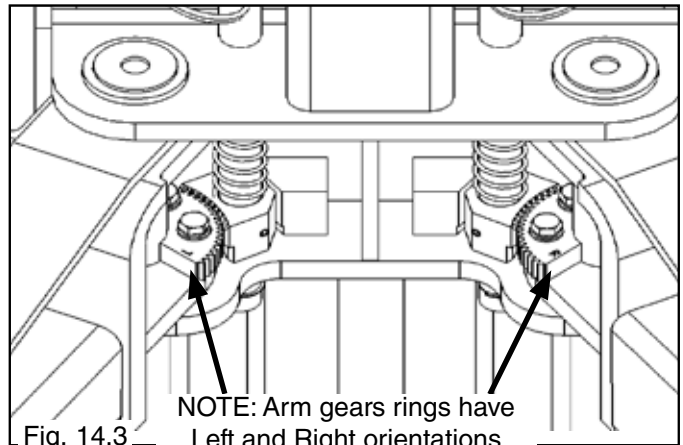

NOTE:
LEFT AND RIGHT ARE DETERMINED WHEN FACING THE INSIDE/OPEN SIDE OF THE LIFT POST.

5. Place each Gear Ring against the Lift Head Pin and align the holes in the Gear Ring with the threaded holes in the Arm Ears. Ensure that the teeth on the Gear Ring mesh smoothly with the teeth on the gears of the Lift Head. (See Fig. 14.5)

6. Verify the operation of the arm restraints by pulling up on the key ring of the arm restraint pin. Pivot the arms back and forth and test the operation of the arm restraint pin in various positions. (See Fig. 14.6)

7. Ensure that the arms do not move when a force of approximately 100 pounds or less is applied laterally to the fully extended arms.

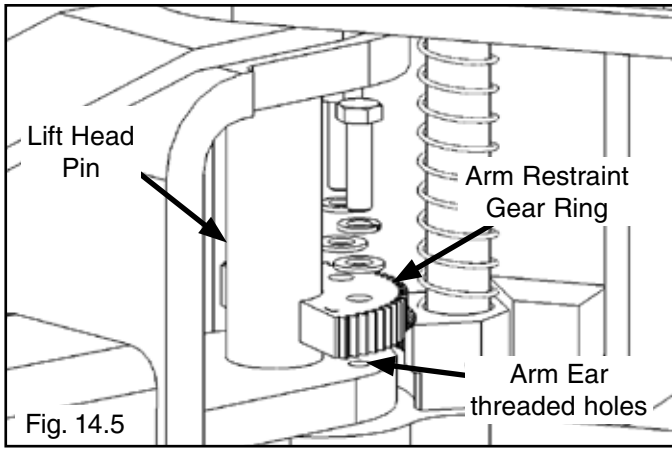

! DANGER

NOTE:
 EACH ARM RESTRAINT ASSEMBLY MUST BE INSPECTED BEFORE EACH AND EVERY TIME THE LIFT IS OPERATED.
 DO NOT OPERATE THE LIFT IF ANY OF THE FOUR ARM RESTRAINT SYSTEMS ARE NOT FUNCTIONING PROPERLY.

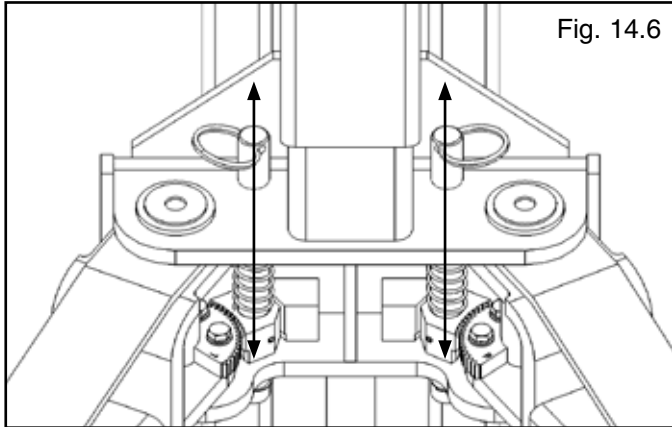

! DANGER

REPLACE ANY BROKEN COMPONENTS OR COMPONENTS WITH BROKEN TEETH ONLY WITH AUTHORIZED OR APPROVED REPLACEMENT PARTS.

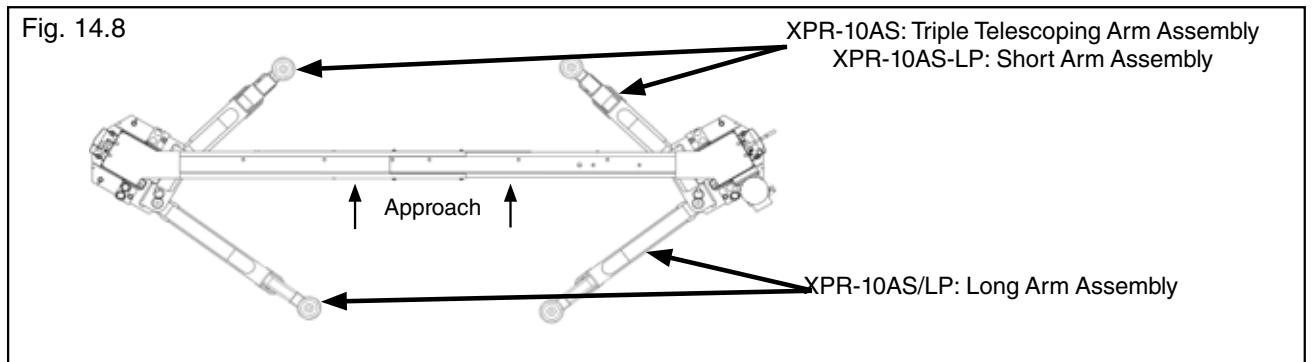
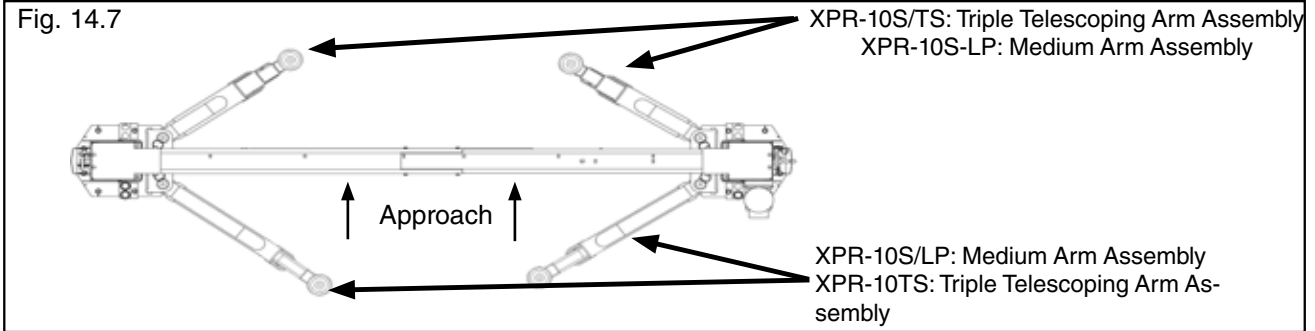

WARNING

IMPORTANT LEVELING INSTRUCTIONS

Before operating your lift, check to make sure that both "A" and "B" measurements are EQUAL.

The lift arms must be level before operation.

If your lift arms are not level, shim the columns as required.

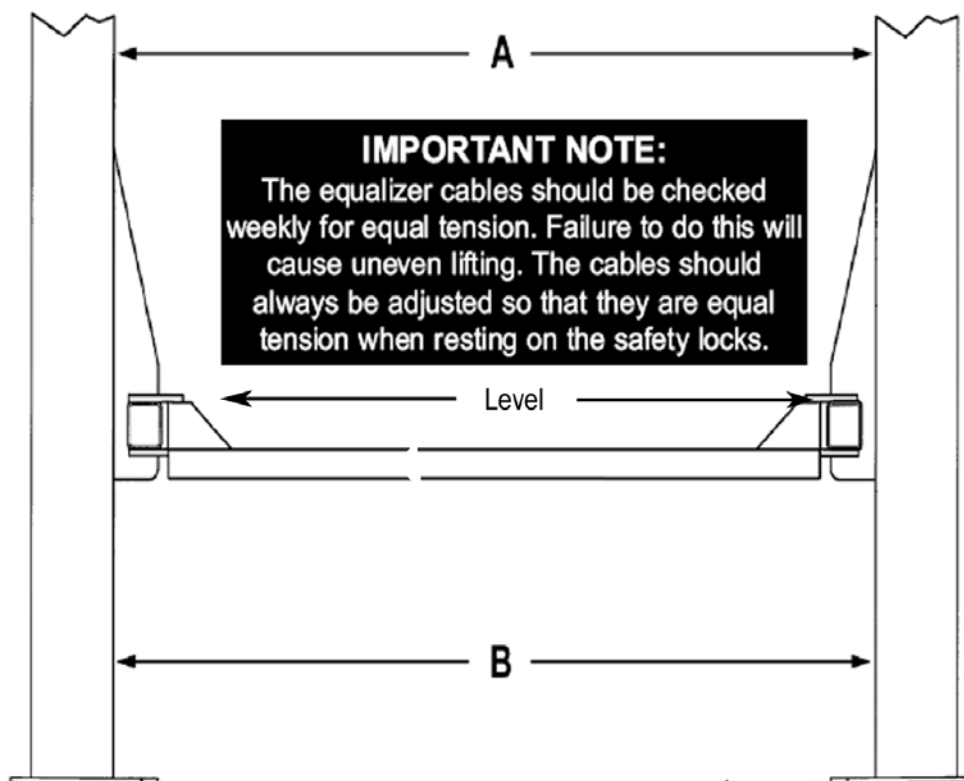

! WARNING

YOU MUST RE-INSTALL TOP CARRIAGE-STOP BOLT (SHOWN BELOW). TIGHTEN CARRIAGE-STOP BOLT TO 2-3 FT.-LBS. OF TORQUE UPON FINAL INSTALLATION INSPECTION. THESE INSTRUCTIONS MUST BE FOLLOWED TO ENSURE PROPER INSTALLATION AND OPERATION OF YOUR LIFT. FAILURE TO COMPLY WITH THESE INSTRUCTIONS CAN RESULT IN SERIOUS BODILY INJURY AND/OR DEATH AND/OR VOID PRODUCT WARRANTY. MANUFACTURER WILL ASSUME NO LIABILITY FOR LOSS OR DAMAGE OF ANY KIND, EXPRESSED OR IMPLIED RESULTING FROM IMPROPER INSTALLATION OR USE OF THIS PRODUCT.

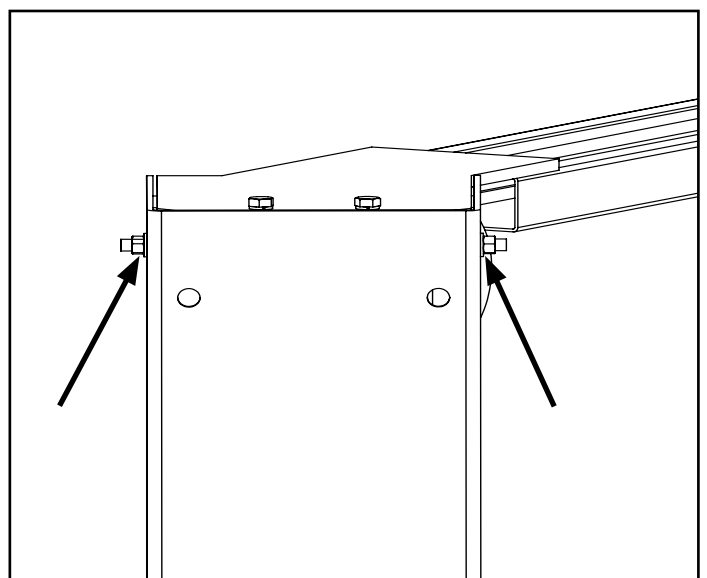
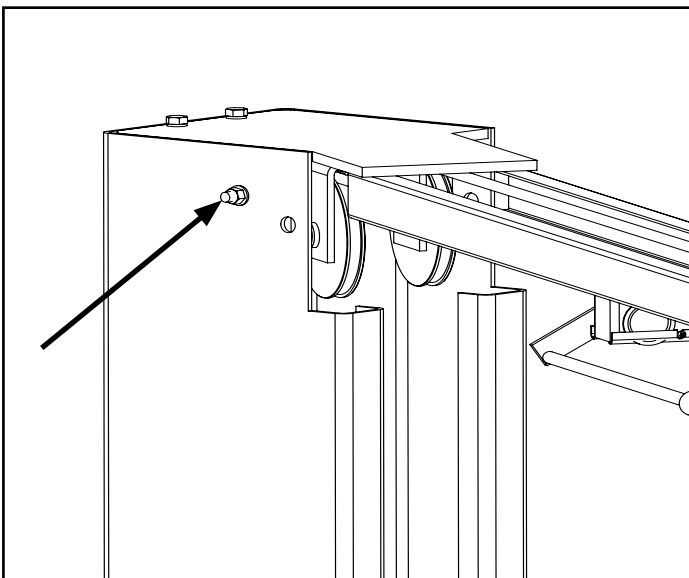
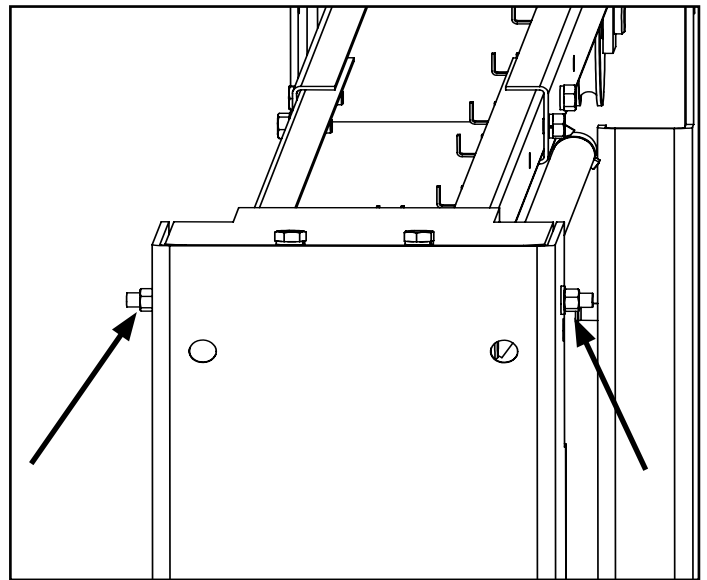
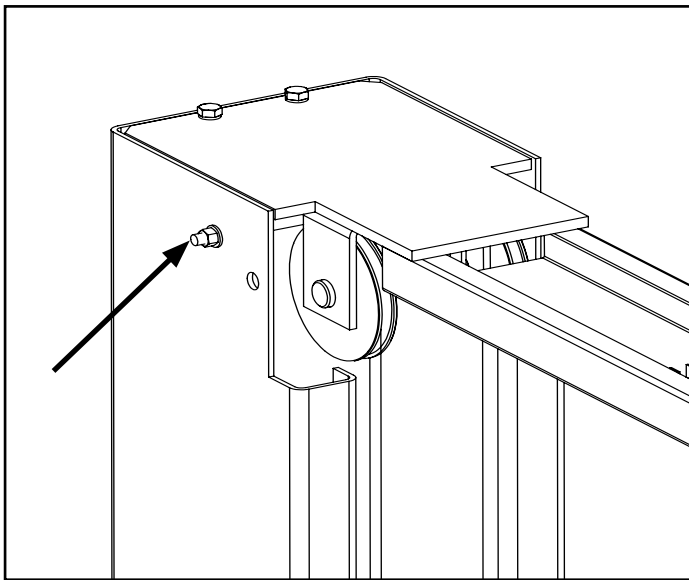



DO NOT PERFORM ANY MAINTENANCE OR INSTALLATION OF ANY COMPONENTS WITHOUT FIRST ENSURING THAT ELECTRICAL POWER HAS BEEN DISCONNECTED AT THE SOURCE OR PANEL AND CANNOT BE RE-ENERGIZED UNTIL ALL MAINTENANCE AND/OR INSTALLATION PROCEDURES ARE COMPLETED.



IMPORTANT POWER-UNIT INSTALLATION NOTES

- DO NOT run power unit without oil. Damage to the pump can occur.
- The power unit must be kept dry. Damage to power unit caused by water or other liquids such as detergents, acid etc., is not covered under warranty.
- Improper electrical connection can damage the motor and will not be covered under warranty.
- Motor cannot run on 50HZ without a physical change in the motor.
- Use a separate breaker for each power unit.
- Protect each circuit with time delay fuse or circuit breaker.
- For 208-230 volt, single phase, use a 25 amp fuse.
- For 208-230 volt, three phase, use a 20 amp fuse.
- For 380-440 volt, three phase, use a 15 amp fuse.

Installation and adjustment.

DO NOT attempt to raise vehicle until a thorough operation check has been completed.

ALL WIRING MUST BE PERFORMED BY A CERTIFIED ELECTRICIAN ONLY

Single Phase

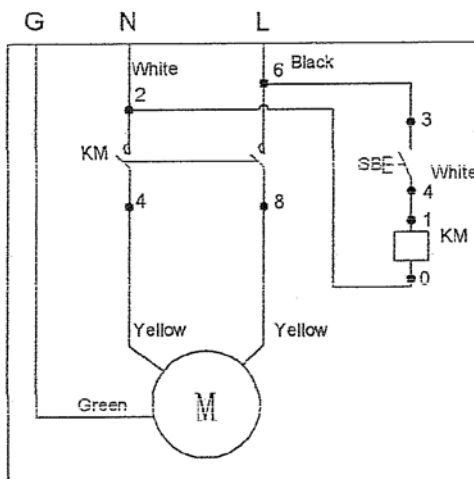

Three Phase

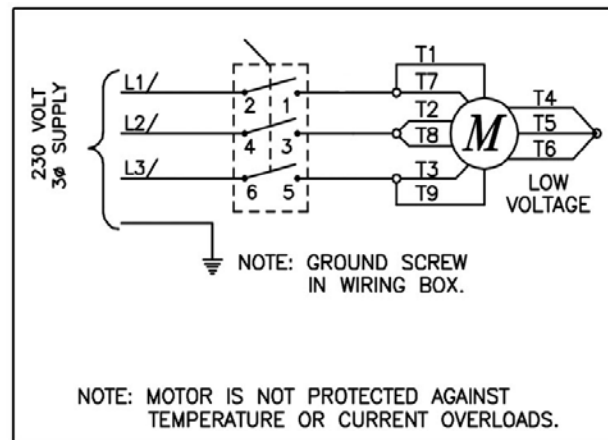

**SEE WIRING INSTRUCTIONS AFFIXED TO
MOTOR FOR PROPER WIRING INSTRUCTIONS.**

WIRING DIAGRAM
Overhead Microswitch
220V Single Phase
XPR TWO POST
06-26-09

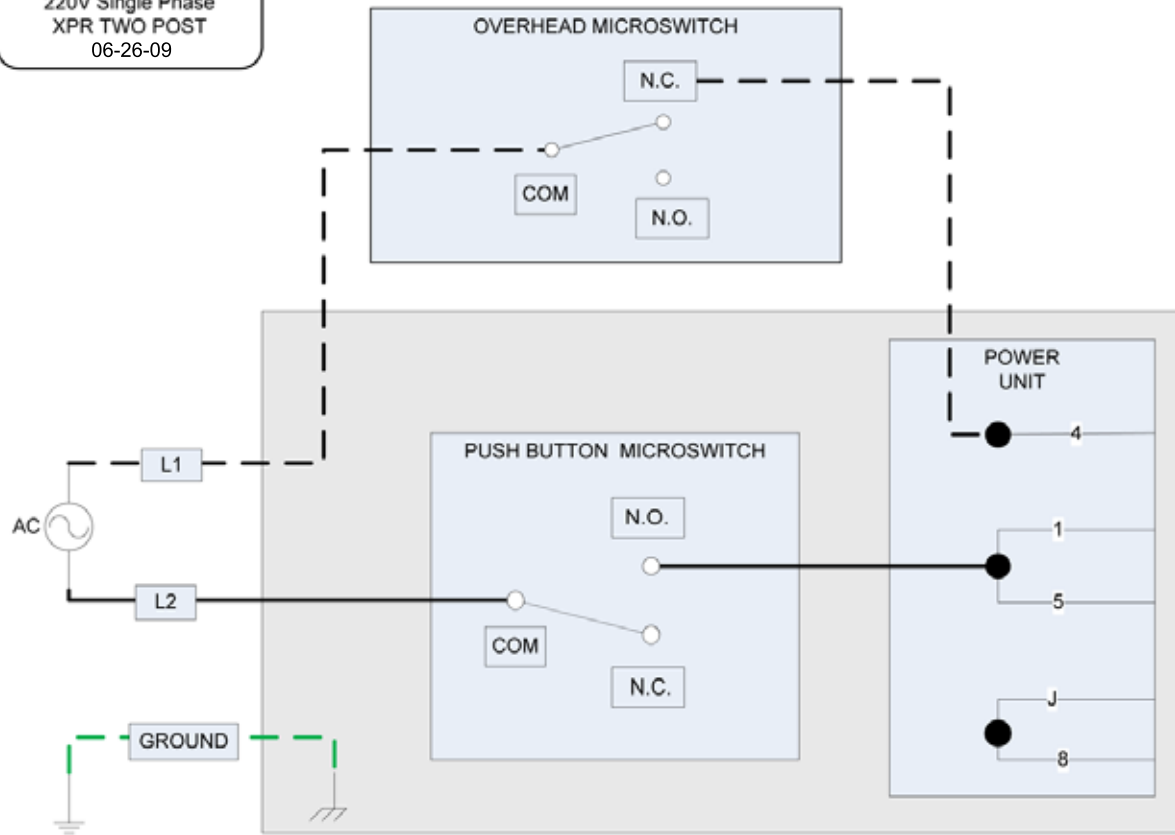

WIRING DIAGRAM
Overhead Microswitch
220V Three Phase
XPR TWO POST
06-26-09

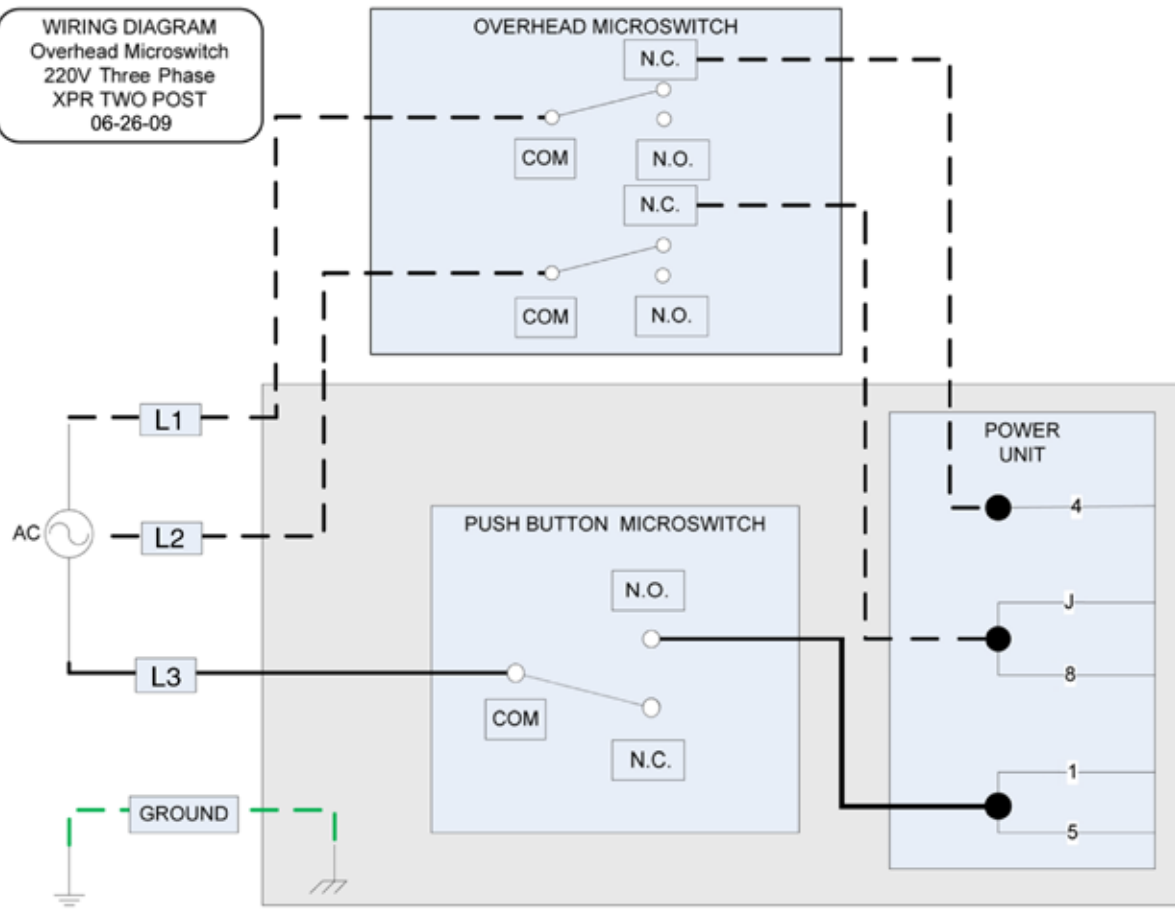

STEP 15 (Power Unit Connection)

1. Have a certified electrician run the power supply to motor. Refer to the data plate found on the motor for proper power supply and wire size.



RISK OF EXPLOSION

This equipment has internal arcing or parts that may spark and should not be exposed to flammable vapors. Motor should not be located in a recessed area or below floor level. NEVER expose motor to rain or other damp environments. DAMAGE TO MOTOR CAUSED BY WATER IS NOT COVERED UNDER WARRANTY.

NOTE

CAUTION NEVER OPERATE THE MOTOR ON LINE VOLTAGE LESS THAN 208V. MOTOR DAMAGE MAY OCCUR WHICH IS NOT COVERED UNDER WARRANTY. HAVE A CERTIFIED ELECTRICIAN RUN APPROPRIATE POWER SUPPLY TO MOTOR. SIZE WIRE FOR 25 AMP CIRCUIT.

SEE MOTOR OPERATING DATA TABLE. USE SEPARATE CIRCUIT FOR EACH POWER UNIT. PROTECT EACH CIRCUIT WITH TIME DELAY FUSE OR CIRCUIT BREAKER.

FOR SINGLE PHASE 208-230V, USE 25 AMP FUSE. THREE PHASE 208-240V, USE 25 AMP FUSE.

FOR THREE PHASE 400V AND ABOVE, USE 15 AMP FUSE. ALL WIRING MUST COMPLY WITH NECK AND ALL LOCAL ELECTRICAL CODES.

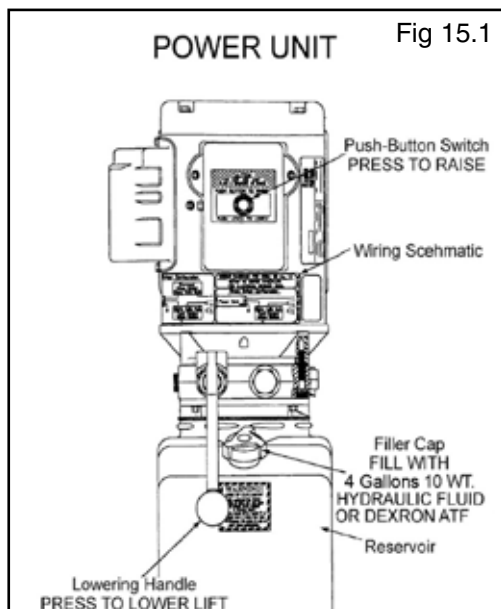

STEP 16 (Lift Start Up / Final Adjustments)



DURING THE START-UP PROCEDURE, OBSERVE ALL OPERATING COMPONENTS AND CHECK FOR PROPER INSTALLATION AND ADJUSTMENT. DO NOT ATTEMPT TO RAISE VEHICLE UNTIL A THOROUGH OPERATIONAL CHECK HAS BEEN COMPLETED.

1. Make sure the power unit reservoir is full with four (4) gallons of 10-WT hydraulic oil, Dexron-III, Dexron VI, Mercon V, Mercon LV or ISO 32 grade transmission fluid.
2. Apply light axle grease to the inside of the posts where the slide blocks glide.
3. Test the power unit by pressing the push-button switch. If the motor sounds like it is operating properly, raise the lift and check all hose connections for leaks. If the motor gets hot or sounds peculiar, stop and check all electrical connections.
4. Before proceeding, double-check to make sure all cables are properly positioned within the grooves of ALL sheaves. Make sure all cable sheave retaining pins and/or clips are secure.
5. Check to make sure that all safety locks are cleared and free.
6. Continue to press the button to raise lift until the cables get taut and the lift starts to move.
7. **KEEP HANDS AND FEET CLEAR.** Remove hands and feet from any moving parts. Keep feet clear of lift when lowering. Avoid pinch points.
8. Check all MAIN SAFETY LOCKS to make sure they move freely and spring back to the lock position when released. Lubricate all SAFETY PIVOT points with light spray oil.
9. Cycle the lift up and down a few times to ensure that the safety locks are engaging uniformly and that the safety release mechanisms are functioning. Re-adjust if necessary.

POST-INSTALLATION CHECK-OFF

- Columns properly shimmed and stable.
- Anchor Bolts tightened.
- Pivot / Sheave Pins properly attached.
- Electric power supply confirmed.
- Cables adjusted properly.
- Safety Locks functioning properly.
- Check for hydraulic leaks.
- Oil level.
- Lubrication of critical components.
- Check for overhead obstructions.
- All Screws, Bolts, and Pins securely fastened.
- Surrounding area clean.
- Operation, Maintenance and Safety Manuals on site.
- Perform an Operational Test with a typical vehicle.

STEP 17 (Lubrication)

1. After installation and start-up have been completed, lubricate lift components as described below.
(See Fig. 17.1)

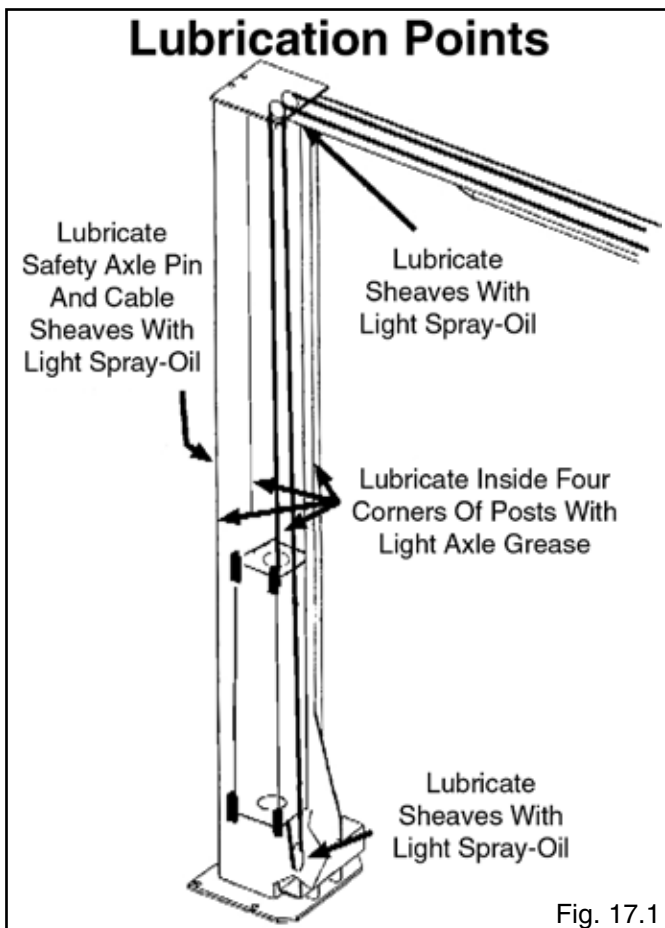

NOTE:

THERE WILL BE INITIAL STRETCHING OF THE CABLES AND/OR WITH INCREASED LOADS. ADJUST THE CABLES AS OUTLINED ABOVE A WEEK AFTER FIRST USE, THEN EVERY THREE TO SIX MONTHS THEREAFTER DEPENDING ON USAGE AND/OR TO COMPENSATE FOR STRETCH.

STEP 18 (Bleeding the Cylinders)



THE LIFT WILL MOVE DOWN WHEN BLEEDING MAKE SURE ALL EQUIPMENT, PERSONNEL, HANDS AND FEET ARE CLEAR FROM THE AREA.

1. After electrical power is connected and oil reservoir is full, press button to raise lift.
2. Continue raising until lift cylinders extend to full height. DON'T continue pressing button after lift reaches full height. Damage to the motor can occur if continued.
3. Lower the lift only HALF WAY by pressing the SAFETY RELEASE handle inward then pressing the DOWN lever on the power unit.
4. With the lift at half height, slowly loosen the BLEED SCREWS located at the top of each cylinder to bleed trapped air. DO NOT completely remove bleed screws. Re-tighten after trapped air has escaped. (See Fig. 18.1)

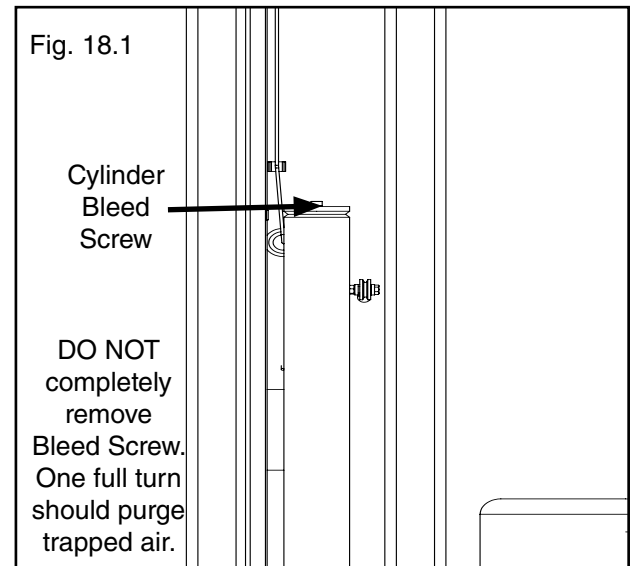

5. Lower the lift completely by pressing the SAFETY RELEASE handle inward then pressing the DOWN lever on power unit. Wait five minutes and repeat bleeding process one additional time.

Utility Air-Electric Workstation

Utility Station may be mounted on the vertical column of the lift or on a wall.

IMPORTANT: Check State or Local codes for any height requirements for the electrical outlets before mounting.

To mount the Utility Station on a Lift Column, use the Box as a template, mark and drill 11/32" diameter holes. Use 5/16" diameter bolts and lock nuts to secure to the side of the lift.

IMPORTANT: The hole locations are critical to avoid interference with the carriage slide blocks.

For Wall mounting, mount in the same fashion use appropriate hardware for either sheet rock or concrete.

IMPORTANT: All electrical wiring shall comply with all State and Local Codes.

Connect electrical wiring to single phase, 60Hz 115 volt electrical supply using suitable conduit (not supplied). The duplex receptacle must be connected through the GFCI with the input line to the box connected to a circuit breaker or time delay fuse rated at 20 amps. Both receptacles must be grounded to the box.

Connect main air supply to 1/4" ball valve inlet on the Utility Station (Run 3/8" line from compressor or main air system to Utility Station.)

Install Quick Couplers to the 1/4" male fittings on the box. The air supply between the filter and the lubricator will be non-lubricated, used for tire inflation or blowing off. The air outlet on the left side will be lubricated for air tool use.

Regulator Instructions

- Regulate pressure by raising the knob, then turning clockwise to increase and counterclockwise to decrease. Push knob down to lock setting.
- Adjust the oil mist using the screwdriver slot located on top of the lubricator.
- To fill the lubricator, first depressurize the air system, remove the slotted screw plug in the body. Replace the screw before repressurizing.

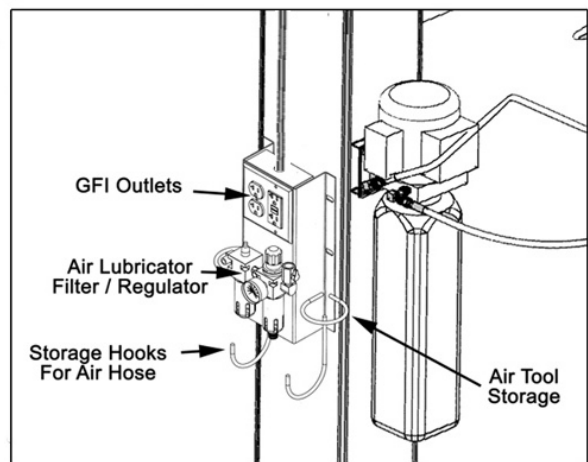
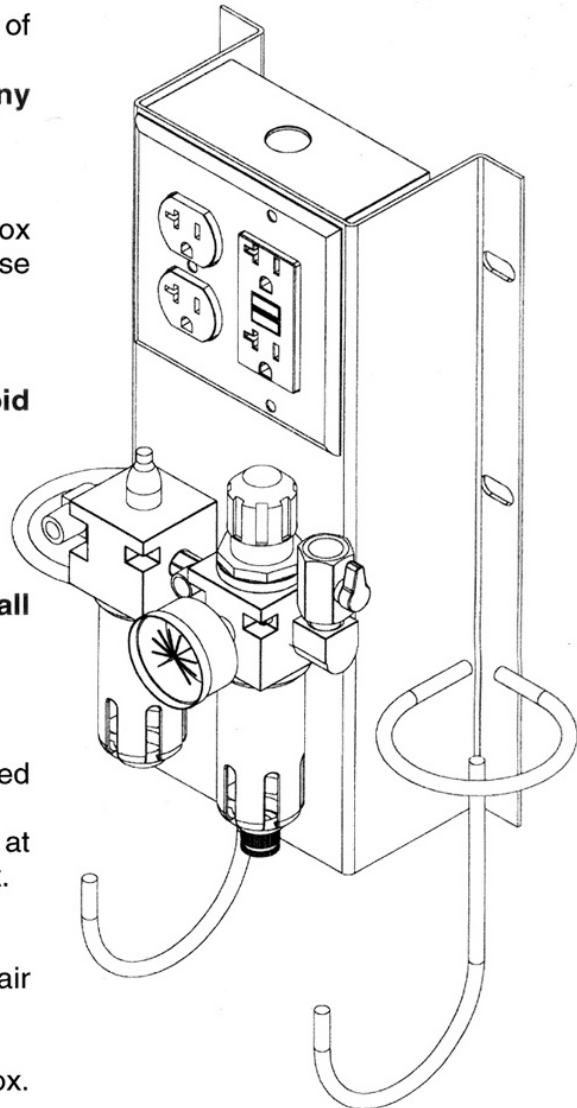

OPTIONAL AND STANDARD ACCESSORIES

Included Standard

Not Included Optional



Model No.	44mm. Adapter	63mm. Adapter	125mm. Adapter	Telescoping Screw Pad	Standard Pad	Frame Cradle Pads
XPR-10S	⊗	☑	⊗	☑	⊗	⊗
XPR-10S-LP	⊗	☑	⊗	☑	⊗	⊗
XPR-10S-168	⊗	☑	⊗	☑	⊗	⊗
XPR-10S-168-LP	⊗	☑	⊗	☑	⊗	⊗
XPR-10TS	⊗	☑	⊗	☑	⊗	⊗
XPR-10TS-168	⊗	☑	⊗	☑	⊗	⊗
XPR-10AS	⊗	☑	⊗	☑	⊗	⊗
XPR-10AS-LP	⊗	☑	⊗	☑	⊗	⊗
XPR-10AS-168	⊗	☑	⊗	☑	⊗	⊗
XPR-10AS-168-LP	⊗	☑	⊗	☑	⊗	⊗

Optional Equipment available through your Authorized BendPak Dealer.



Telescoping Screw Pad



Frame Cradle Pad

! DANGER

SKU# 5715016

FRAME CRADLE CONTACT PADS

USE PROPER ADAPTERS

Do not attempt to lift trucks or other frame type vehicles with standard flat contact pads. Frame cradle contact pads are recommended for use when lifting trucks, vans, or other frame vehicles. NEVER use lift with missing or damaged rubber pads. ALWAYS REPLACE rubber contact pads when worn or damaged. Contact BendPak or your BendPak dealer for product information.

If the lift was provided with Lift Arm Foot Guards, install the shorter Foot Guard on the shorter Arm Assembly and the longer Foot Guard on the longer Arm Assembly.

To install, firmly squeeze the ends of the Foot Guard inwards and insert the ends underneath the bent ends of the arm support. Release to allow the Foot Guard to spring into place. Check to be sure that Foot Guard is firmly in place.

Repeat this step for each Arm Assembly Foot Guard.

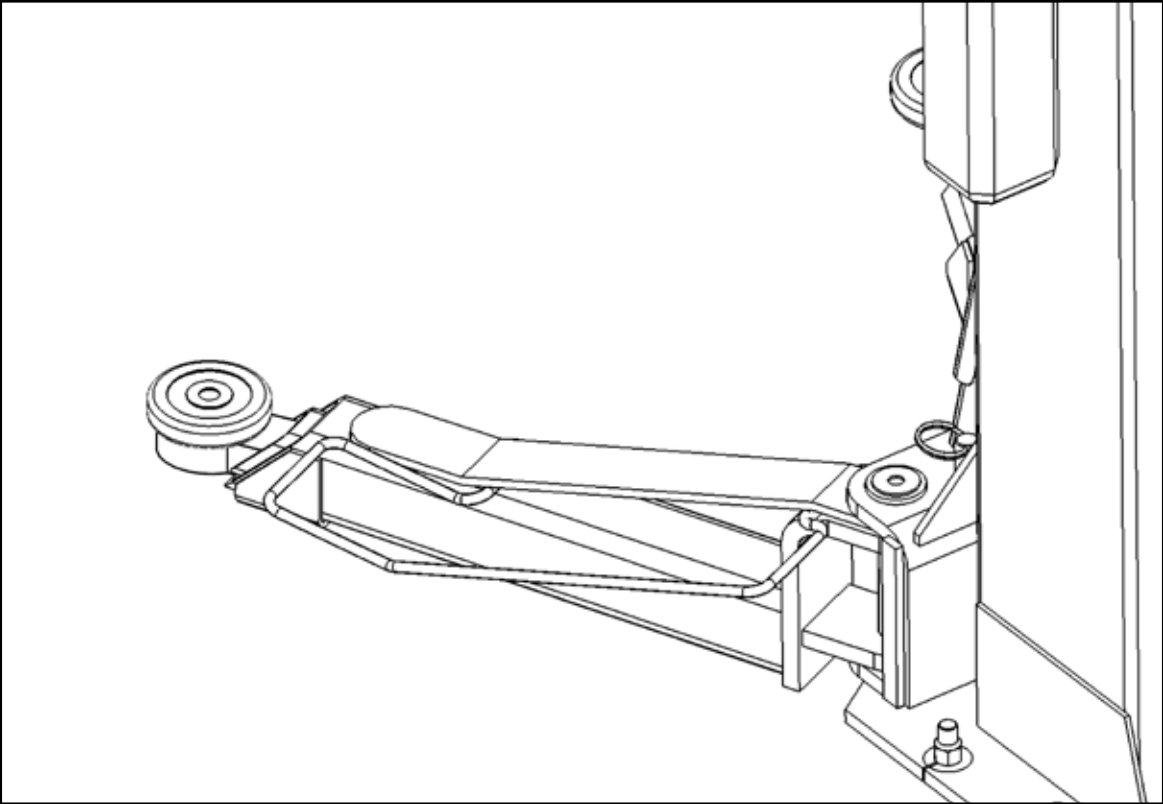
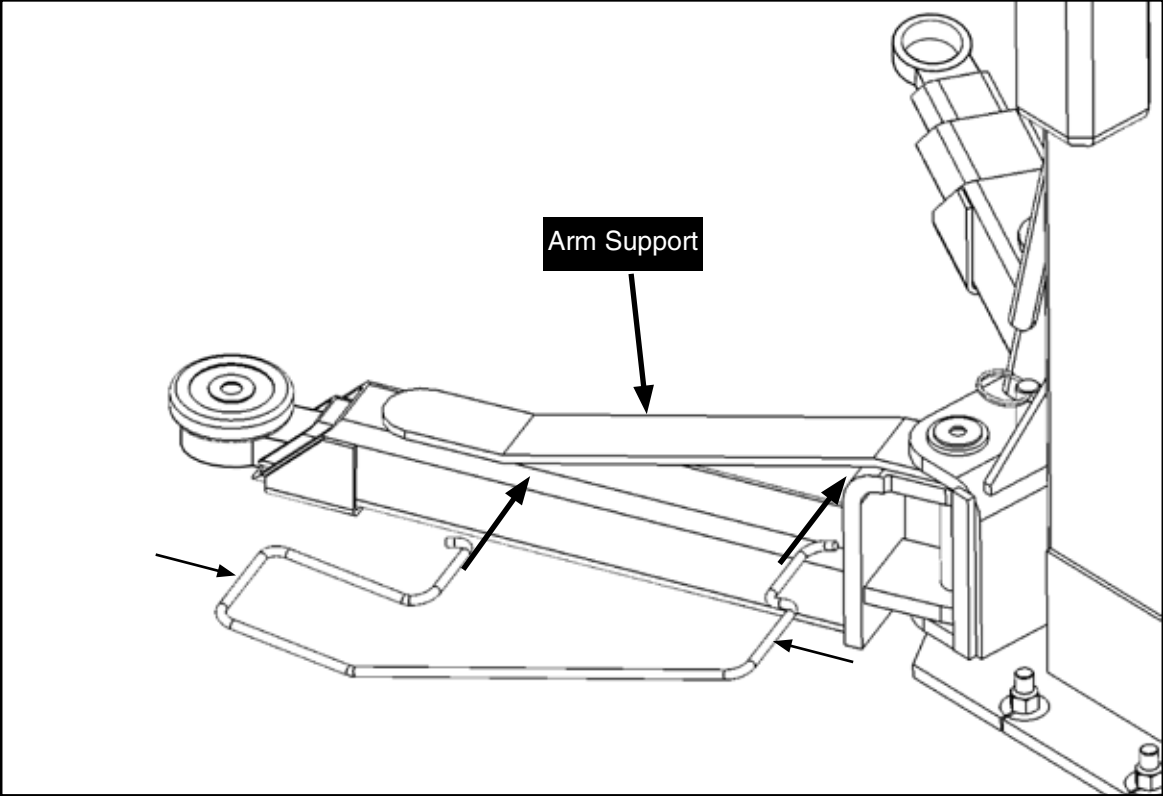

STEP 19 (Operation Instructions)

OWNER/EMPLOYER RESPONSIBILITIES

The Owner/Employer:

- Shall ensure that lift operators are qualified and that they are trained in the safe use and operation of the lift using the manufacturer's operating instructions; ALI/SM01-1, ALI Lifting it Right safety manual; ALI/ST-90 ALI Safety Tips card; ANSI/ALI ALOIM-2000, American National Standard for Automotive Lifts-Safety Requirements for Operation, Inspection and Maintenance; ALI/WL Series, ALI Uniform Warning Label Decals/Placards; and in the case of frame engaging lifts, ALI/LP-GUIDE, Vehicle Lifting Points/Quick Reference Guide for Frame Engaging Lifts.

- Shall establish procedures to periodically inspect the lift in accordance with the lift manufacturer's instructions or ANSI/ALI ALOIM-2000, American National Standard for Automotive Lifts-Safety Requirements for Operation, Inspection and Maintenance; and The Employer shall ensure that lift inspectors are qualified and that they are adequately trained in the inspection of the lift.

- Shall establish procedures to periodically maintain the lift in accordance with the lift manufacturer's instructions or ANSI/ALI ALOIM-2000, American National Standard for Automotive Lifts-Safety Requirements for Operation, Inspection and Maintenance; and The Employer shall ensure that lift maintenance personnel are qualified and that they are adequately trained in the maintenance of the lift.

- Shall maintain the periodic inspection and maintenance records recommended by the manufacturer or ANSI/ALI ALOIM-2000, American National Standard for Automotive Lifts-Safety Requirements for Operation, Inspection and Maintenance.

- **DAILY** inspect your lift. Never operate if it malfunctions or if it has broken or damaged parts. Use **only** qualified lift service personnel and genuine BendPak parts to make repairs.

- **THOROUGHLY** train all employees in use and care of lift, using manufacturer's instructions and "Lifting It Right" and "Safety Tips" supplied with the lift.

- **NEVER** allow unauthorized or untrained persons to position vehicle or operate lift.

- **PROHIBIT** unauthorized persons from being in shop area while lift is in use.

- **DO NOT** permit anyone on lift or inside vehicle when it is either being raised or lowered.

- Shall display the lift manufacturer's operating instructions; ALI/SM 93-1, ALI Lifting It Right safety manual; ALI/ST-90 ALI Safety Tips card; ANSI/ALI ALOIM-2000, American National Standard for Automotive Lifts-Safety Requirements for Operation, Inspection and Maintenance; and in the case of frame engaging lifts, ALI/LP-GUIDE, Vehicle Lifting Points/Quick Reference Guide for Frame Engaging Lifts; in a conspicuous location in the lift area convenient to the operator.

- Shall provide necessary lockout/tagout means for energy sources per ANSI Z244.1-1982 (R1993), Safety Requirements for the Lockout/Tagout of Energy Sources, before beginning any lift repairs.

- Shall not modify the lift in any manner without the prior written consent of the manufacturer.



LIFT OPERATION SAFETY

- **DAILY** inspect your lift. Never operate if it malfunctions or if it has broken or damaged parts. Use **only** qualified lift service personnel and genuine BendPak parts to make repairs.

- **THOROUGHLY** train all employees in use and care of lift, using manufacturer's instructions and "Lifting It Right" and "Safety Tips" supplied with the lift.

- **NEVER** allow unauthorized or untrained persons to position vehicle or operate lift.

- **PROHIBIT** unauthorized persons from being in shop area while lift is in use.

- **DO NOT** permit anyone on lift or inside vehicle when it is either being raised or lowered.

- **ALWAYS** keep area around lift free of tools, debris, grease and oil.

- **NEVER** overload lift. Capacity of lift is shown on nameplate affixed to the lift.

- **DO NOT** stand in front of the vehicle while it is being positioned in lift bay.

- **DO NOT** hit or run over lift arms or adapters. This could damage lift or vehicle. Before driving vehicle into lift bay, position arms and adapters to provide unobstructed entrance onto lift.

LIFT OPERATION SAFETY (CONT'D)

- **ALWAYS** load vehicle on lift carefully. Position the lift adapters to contact at the vehicle manufacturer's recommended lift points. Raise lift until adapters contact vehicle. Check adapters for secure contact with vehicle. Raise lift to desired working height. (See Fig.19.1)

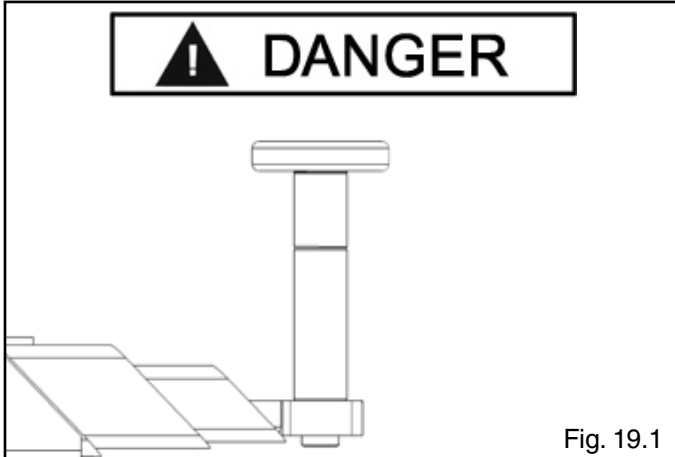

- **DO NOT** block open or override self-closing lift controls; they are designed to return to the "Off" or Neutral position when released.
- **DO NOT** remove or disable arm restraints.
- **ALWAYS** remain clear of lift when raising or lowering vehicles.
- **ALWAYS** use safety stands when removing or installing heavy components.
- **DO NOT** go under raised vehicle if safety locks are not engaged.



VISUALLY CONFIRM THAT ALL PRIMARY SAFETY LOCKS ARE ENGAGED BEFORE ENTERING WORK AREA. SUSPENSION COMPONENTS USED ON THIS LIFT ARE INTENDED TO RAISE AND LOWER LIFT ONLY AND ARE NOT MEANT TO BE LOAD HOLDING DEVICES. REMAIN CLEAR OF ELEVATED LIFT UNLESS VISUAL CONFIRMATION IS MADE THAT ALL PRIMARY SAFETY LOCKS ARE FULLY ENGAGED AND THE LIFT IS LOWERED ONTO THE SAFETY LOCKS, REFER TO INSTALLATION/ OPERATION MANUAL FOR PROPER SAFETY LOCK PROCEDURES AND/OR FURTHER INSTRUCTION.

- **NEVER LEAVE LIFT IN ELEVATED CONDITION** unless all Safety Locks are engaged.
- **AVOID** excessive rocking of vehicle while on lift.
- **ALWAYS CLEAR AREA** if vehicle is in danger of falling.



WHEN LOWERING THE LIFT PAY CAREFUL ATTENTION THAT ALL PERSONNEL AND OBJECTS ARE KEPT CLEAR. ALWAYS KEEP A VISUAL LINE OF SITE ON THE LIFT AT ALL TIMES. ALWAYS MAKE SURE THAT ALL LOCKS ARE DISENGAGED. IF ONE OF THE LOCKS INADVERTENTLY LOCKS UPON DESCENT THE VEHICLE MAY DISMOUNT CAUSING PERSONAL INJURY OR DEATH.

- **ALWAYS REMOVE** tool trays, stands, etc. before lowering lift.
- **ALWAYS RELEASE** safety locks before attempting to lower lift.
- **ALWAYS POSITION** the lift arms and adapters to provide an unobstructed exit before removing vehicle from lift area.

TO RAISE THE LIFT

1. Before Loading: Lift must be fully lowered and service bay clear of all personnel before the vehicle is brought onto lift with the swing arms set to the full drive-thru position.



TO AVOID PERSONAL INJURY AND/OR PROPERTY DAMAGE, PERMIT ONLY TRAINED PERSONNEL TO OPERATE LIFT. AFTER REVIEWING THESE INSTRUCTIONS, PRACTICE USING LIFT CONTROLS BY RUNNING THE LIFT THROUGH A FEW UNLOADED CYCLES BEFORE LOADING VEHICLE ON LIFT. ALWAYS LIFT THE VEHICLE USING ALL FOUR ADAPTERS. **NEVER** RAISE JUST ONE END, ONE CORNER, OR ONE SIDE OF VEHICLE.

2. Loading: Swing arms under vehicle and position adapters at vehicle manufacturer's recommended lift points. Use height extenders or optional frame-cradle adapters when necessary to ensure good contact. (See Fig 19.2 - 19.3)
3. Some vehicles may have the manufacturer's Service Garage Lift Point locations identified by triangle shape marks on the undercarriage (reference ANSI/SAE J2184-1992). Also, there may be a label located on the right front door jamb area showing specific vehicle lift points.

LIFT OPERATION SAFETY (CONT'D)

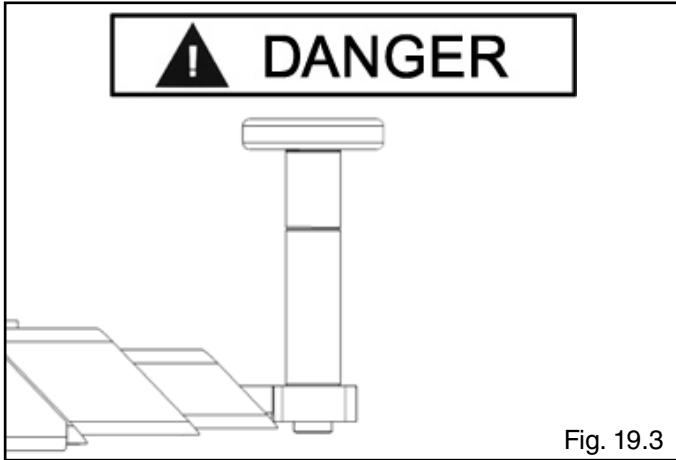
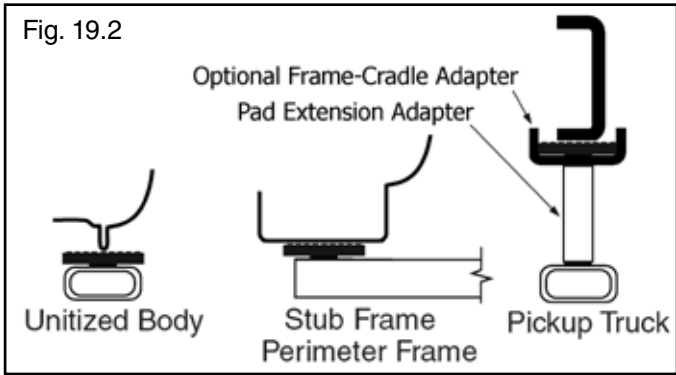

MANY SPECIALTY OR MODIFIED VEHICLES CANNOT BE RAISED ON A TWO-POST FRAME ENGAGING LIFT. CONTACT VEHICLE MANUFACTURER FOR RAISING OR JACKING DETAILS.

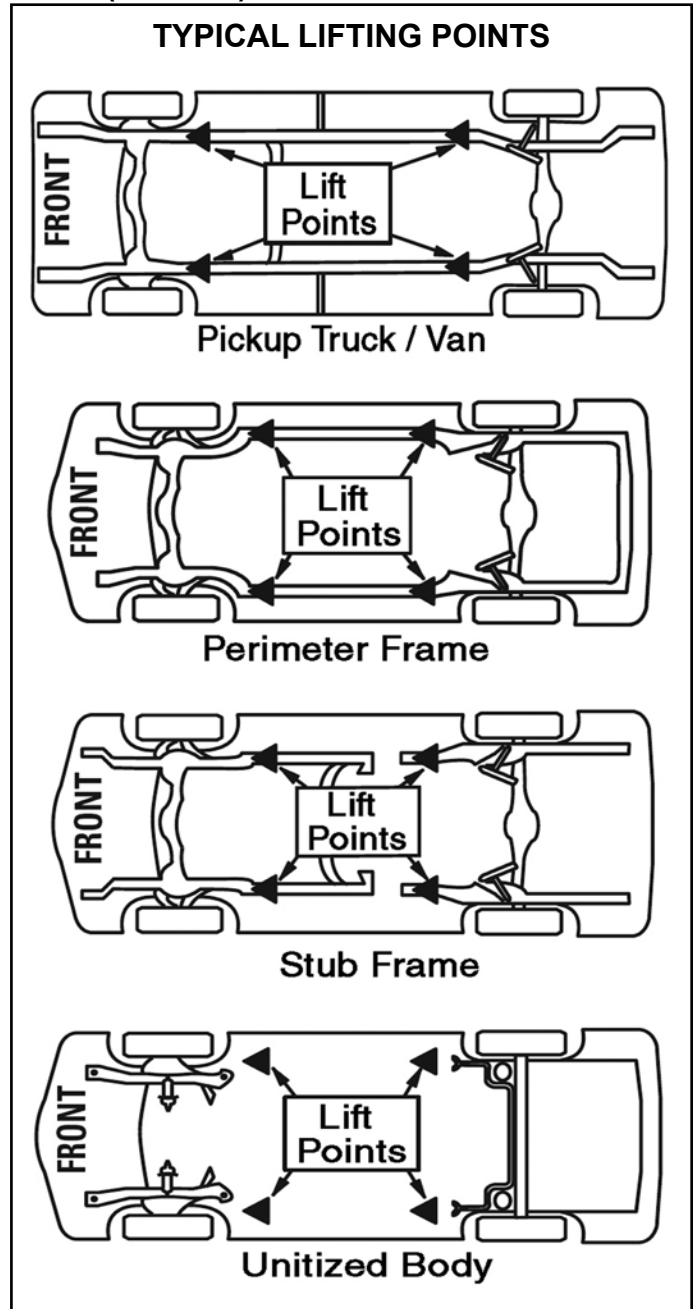
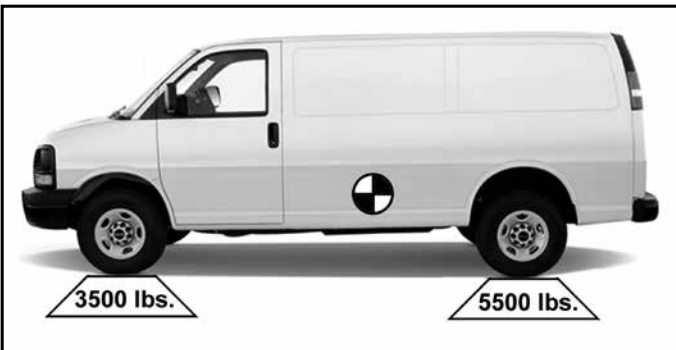

5. If the specific vehicle lift points are not identified, refer

NOTE:
ALLOW (2) SECONDS BETWEEN MOTOR STARTS.
FAILURE TO COMPLY MAY CAUSE MOTOR BURNOUT.

to the VEHICLE CENTER OF BALANCE instructions found on our website at:

www.bendpak.com/support/balancing-safety/

4. Position vehicle for proper weight distribution arms under vehicle to allow adapters to contact at the manufacturer's recommended pick up points.

LIFT OPERATION SAFETY (CONT'D)

6. Push the **RAISE** button or rotate the control switch on the power unit.

7. Stop before making contact with vehicle. Check arm restraint pins for engagement. If required, slightly move arm to allow restraint gear and pawl to mesh. **DO NOT** hammer arm restraint pin down as this will damage the restraint gear teeth.



VISUALLY CONFIRM THAT ALL PRIMARY SAFETY LOCKS ARE ENGAGED BEFORE ENTERING WORK AREA. SUSPENSION COMPONENTS USED ON THIS LIFT ARE INTENDED TO RAISE AND LOWER LIFT ONLY AND ARE NOT MEANT TO BE LOAD HOLDING DEVICES. REMAIN CLEAR OF ELEVATED LIFT UNLESS VISUAL CONFIRMATION IS MADE THAT ALL PRIMARY SAFETY LOCKS ARE FULLY ENGAGED AND THE LIFT IS LOWERED ONTO THE SAFETY LOCKS, REFER TO INSTALLATION /OPERATION MANUAL FOR PROPER SAFETY

8. Raise vehicle until tires clear the floor.

9. Stop and check adapters for secure contact at vehicle manufacturer's recommended lift points.

10. Continue to raise to desired height only if vehicle is secure on lift.

11. **DO NOT** go near or under a raised vehicle if all four adapters are not in secure contact with vehicle at vehicle manufacturer's recommended lift points.

12. Repeat entire loading and raising procedures if required.

13. Lower lift onto safety locks.

- **DO NOT** enter work area or go under vehicle if safety locks are not engaged.

- **CLEAR AREA** if vehicle is in danger of falling.

- **DO NOT** position yourself between a wall and the lift. If the vehicle falls in that direction, you may be severely injured or killed.

- Before attempting to lift pickup trucks or other truck frame vehicles, be sure that:

- ◆ Vehicle frame is strong enough to support its weight and has not been weakened by modification or corrosion.
- ◆ Vehicle individual axle weight does not exceed one-half lift capacity.



WHEN LOWERING THE LIFT PAY CAREFUL ATTENTION THAT ALL PERSONNEL AND OBJECTS ARE KEPT CLEAR. ALWAYS KEEP A VISUAL LINE OF SITE ON THE LIFT AT ALL TIMES. ALWAYS MAKE SURE THAT ALL LOCKS ARE DISENGAGED. IF ONE OF THE LOCKS INADVERTENTLY LOCKS ON DESCENT THE LIFT AND/OR VEHICLE MAY DISRUPT CAUSING PERSONAL INJURY OR DEATH.

- ◆ Adapters are in secure contact with frame at vehicle manufacturers recommended lift points.
- ◆ Vehicle is stable on lift and the center of gravity is NOT off balance.
- ◆ The overhead switch bar will contact the highest point on the vehicle.

WHILE USING LIFT

- Avoid excessive rocking of vehicle while on lift.
- Always use safety stands as needed or when removing or installing heavy components.

TO LOWER THE LIFT

1. Remove all tools or other objects from the lift area.
2. Raise lift off safety locks.
3. Push safety lock release handle fully and hold.
4. Push LOWERING valve handle to lower. Note: Both SAFETY LOCK release and LOWERING valve handles must be held down simultaneously to lower lift. Do not override self-closing lift controls.
5. Remain clear of lift when lowering vehicle. Observe pinch point warning decals.



IF YOU ARE NOT COMPLETELY FAMILIAR WITH AUTOMOTIVE LIFT MAINTENANCE PROCEDURES; **STOP** AND CONTACT THE MANUFACTURER FOR INSTRUCTIONS. TO AVOID PERSONAL INJURY, PERMIT ONLY QUALIFIED PERSONNEL TO PERFORM MAINTENANCE ON THIS EQUIPMENT.

6. Remove adapters from under vehicle and swing arms to full drive-thru position before moving vehicle.

7. If lift is not operating properly, **DO NOT** use until adjustment or repairs are made by qualified lift service personnel.

LIFT OPERATION SAFETY (CONT'D)

MAINTENANCE INSTRUCTIONS

- Always keep bolts tight. Check periodically.
- Always keep lift components clean.
- Always if oil leakage is observed, call local service representative.
- Always call local service representative if electrical problems develop.
- Always replace ALL FAULTY PARTS before lift is put back into operation.
- Daily: Make a visual inspection of ALL MOVING PARTS and check for excessive signs of wear.
- Daily: Check safety locks to ensure they are in good operating condition.
- Daily: Check cables and sheaves for wear. Replace worn parts as required with genuine BendPak parts.
- Daily: Inspect adapters for damage or excessive wear. Replace as required with genuine BendPak parts.
- Weekly: Lubricate all sheave and rollers with general purpose oil.
- Weekly: Check all cable connections, bolts and pins to ensure proper mounting.
- Monthly: Check equalizer cable tension. Adjust per lift installation instructions.
- Monthly: Lubricate locking latch shafts. Push latch handle several times for oil to penetrate pivot points.
- Every 3 Months: Check anchor bolt torque. Anchors should be torqued to 90 ft. / lbs.
- Semi-Annually: Check fluid level of lift power unit and refill if required per lift installation instructions.
- Replace all caution, warning or safety related decals on the lift if unable to read or missing. Reorder labels from BendPak.
- Refer to ANSI/ALI ALOIM booklet for periodic inspection checklist and maintenance log sheet.

WARNING

Make sure vehicle is neither front nor rear heavy and select the proper configuration for the vehicle to be lifted (symmetric/asymmetric) as shown below. Center of balance should be midway between adapters.

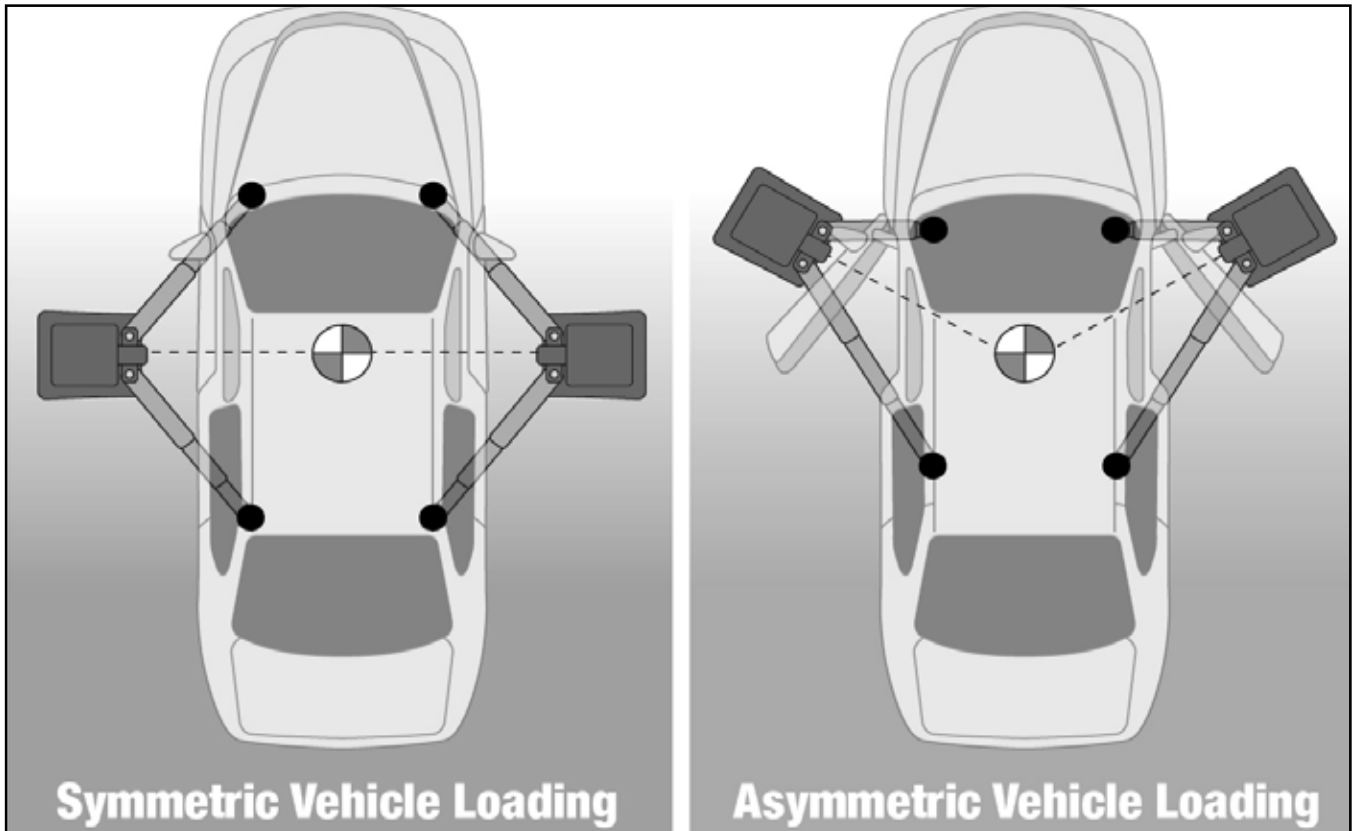

TO RAISE LIFT

- ◆ Read operating and safety manuals before using lift.
- ◆ Always lift a vehicle according to the manufacturers recommended lifting points.
- ◆ Position vehicle between posts.
- ◆ Adjust swing arms so that the vehicle is positioned with the center of gravity midway between pads.
- ◆ Use truck adapters as needed. Never exceed 9" of Pad height.
- ◆ **NEVER** use lift pad assemblies without rubber slip over pads in place.
- ◆ Raise the vehicle by depressing button until the vehicle just lifts off the ground. Re-check to make sure the vehicle is secure and all locking pins are locked in place.
- ◆ Raise vehicle to desired height. Lower vehicle onto nearest safety.
- ◆ Always ensure safeties are engaged before any attempt is made to work on or near vehicle.

TO LOWER THE LIFT

- ◆ First raise the lift in order to disengage the safeties.
- ◆ Release safeties by pushing on the safety handle.
- ◆ Be sure tool trays, stands or personnel are cleared from under the vehicle.
- ◆ Lower vehicle by activating lowering handle on power unit.
- ◆ Before removing vehicle from lift, position lift arms and supports to provide an unobstructed exit.
- ◆ **NEVER** drive over lift arms.

REQUIRED MONTHLY MAINTENANCE

- ◆ Check all arm adjusting locks for proper operation.
- ◆ Check all cables connections, bolts and pins to ensure proper mounting and torque.
- ◆ Visually inspect safeties for proper operation.
- ◆ Lubricate posts with grease.
- ◆ Inspect all anchor bolts and retighten if necessary.
- ◆ Check all posts for squareness and plumb.
- ◆ Inspect all pivot arms pins making sure they are properly secure.
- ◆ Check equalizer cable tension, and adjust if necessary.
- ◆ If the lift is equipped with an overhead microswitch, check for proper operation.



1. If cement anchor bolts are loose or any component of the lift is found to be defective, **DO NOT USE THE LIFT.**
2. Never operate the lift with any person or equipment below the vehicle.
3. Never exceed the rated lift capacity.
4. Always ensure the safeties are engaged before any attempt is made to work on or near the vehicle.
5. Never leave the lift in elevated position unless the safeties are engaged.
6. Do not permit electric motor to get wet! Motor damage caused by dampness is not covered under warranty.

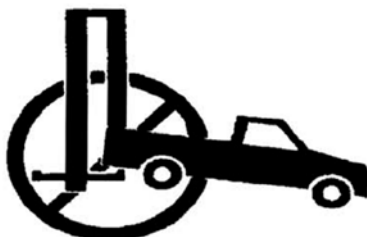

**NEVER LIFT A VEHICLE IN ANY MANNER WITH
LESS THAN ALL FOUR (4) ARMS.
RATED CAPACITY OF EACH LIFT ARM IS NO GREATER
THAN ONE FOURTH (1/4) OF THE OVERALL LIFT CAPACITY.**



WIRE ROPE INSPECTION AND MAINTENANCE

◆ Lifting cables should be replaced every three - five years or when visible signs of damage are apparent. **DO NOT USE LIFT WITH DEFECTIVE / WORN CABLES.**

◆ Lifting cables should be maintained in a well-lubricated condition at all times. Wire rope is only fully protected when each wire strand is lubricated both internal and external. Excessive wear will shorten the life of the wire rope. The factory suggested wire rope lubricant that penetrates to the core of the rope and provides long-term lubrication between each individual strand is 90-WT gear oil or ALMASOL® Wire Rope Lubricant. In order to make sure that the inner layers of the rope remain well lubricated, lubrication should be carried out at intervals not exceeding three months during operation.

◆ All sheaves and guide rollers in contact with the moving rope should be given regular visual checks for surface wear and lubricated to make sure that they run freely. This operation should be carried out at appropriate intervals generally not exceeding three months during operation. For all sheave axles, the factory recommends standard wheel bearing grease. For all sheaves and/or guide rollers, the factory recommends 90-WT gear oil or similar heavy lubricant applied by any method including pump / spray dispensing, brush, hand and/or swabbing.

HOW OFTEN TO INSPECT

◆ Lifting cables should be visually inspected at least once each day when in use, as suggested by American Petroleum Institute (API) RP54 guidelines.

◆ Any lifting cables that have met the criteria for removal must be immediately replaced.

WHEN TO REPLACE LIFTING CABLES DUE TO BROKEN WIRES

◆ Lifting cables should be removed from service when you see six randomly distributed broken wires within any one lay length, or three broken wires in one strand within one lay length.

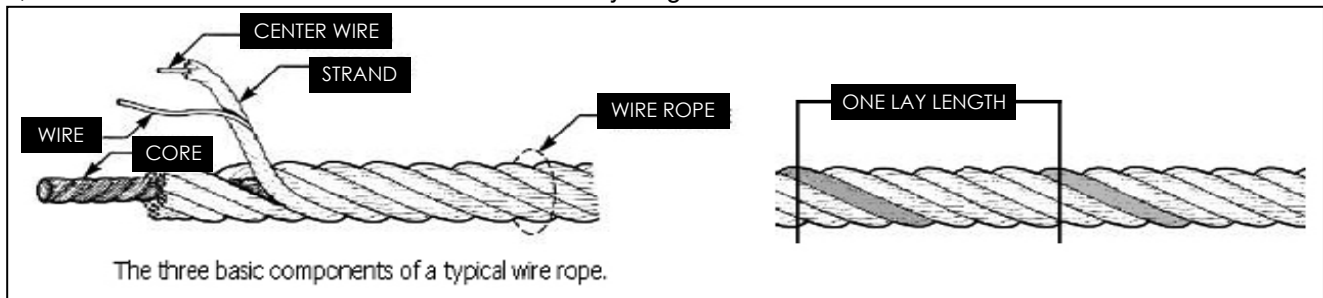

The three basic components of a typical wire rope.

OTHER REASONS TO REPLACE LIFTING CABLES

- ◆ Corrosion that pits the wires and/or connectors.
- ◆ Evidence of kinking, crushing, cutting, bird-caging or a popped core.
- ◆ Wear that exceeds 10% of a wire's original diameter.
- ◆ Evidence of heat damage.

HOW TO FIND BROKEN WIRES

◆ The first step is to relax your rope to a stationary position and move the pick-up points off the sheaves. Clean the surface of the rope with a cloth — a wire brush, if necessary — so you can see any breaks.

◆ Flex the rope to expose any broken wires hidden in the valleys between the strands.

◆ Visually check for any broken wires. One way to check for crown breaks is to run a cloth along the rope to check for possible snags.

◆ With an awl, probe between wires and strands and lift any wires that appear loose. Evidence of internal broken wires may require a more extensive rope examination.

⚠ WARNING

WIRE ROPE INSPECTION AND MAINTENANCE

- Lifting cables should be replaced every three years or when visible signs of damage are apparent. **DO NOT USE LIFT WITH DEFECTIVE: WORN CABLES.**
- Wire rope should be maintained in a well-lubricated condition at all times. Wire rope is only fully protected when each wire strand is lubricated both internally and externally. Excessive wear will shorten the life of the wire rope. The factory suggested wire rope lubricant that penetrates to the core of the rope and provides long term lubrication between each individual strand is AMSOIL Synthetic Open Gear and Wire Rope Compound or 90WT gear oil or similar heavy lubricant. In order to make sure that the inner layers of the rope remains well lubricated, lubrication should be carried out at intervals not exceeding three months during operation.
- All sheaves and guide rollers in contact with the moving rope should be given regular visual checks for surface wear and lubricated to make sure that they run freely. This operation should be carried out at appropriate intervals generally not exceeding three months during operation. For all sheave axles, the factory recommends standard wheel bearing grease. For all sheaves and /or guide rollers, the factory recommends 90 WT gear oil or similar heavy lubricant applied by any method including pump / spray dispensing, brush, hand and /or swabbing.

Failure to read, understand, and follow these instructions may cause death or serious injury.
Read and understand these instructions before using lift.

SAFETY INSTRUCTIONS



Read operating and safety manuals before using lift.

©

SAFETY INSTRUCTIONS



Proper maintenance and inspection is necessary for safe operation.

©

SAFETY INSTRUCTIONS



Do not operate a damaged lift.

©

The messages and pictographs shown are generic in nature and are meant to generally represent hazards common to all automotive lifts regardless of specific style

Funding for the development and validation of these labels was provided by the Automotive Lift Institute, PO Box 33116 Indianalantic, FL 32903

They are protected by copyright
Set of labels may be obtained from
ALI or its member companies

© 1992 by ALI, Inc

ALI/WL1018



CAUTION
Lift to be used
by trained operator
only.

©



CAUTION
Authorized personnel
only in lift area.

©



WARNING
Clear area if vehicle
is in danger of falling.

©



WARNING
Position vehicle
with center of gravity
midway between
adapters.

©

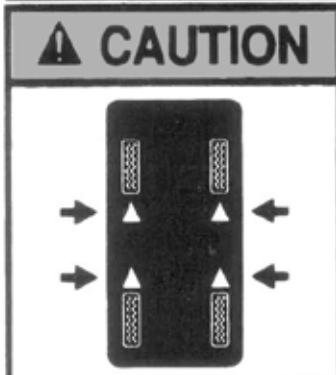

CAUTION
Use vehicle
manufacturer's
lift points.

©



CAUTION
Always use
safety stands when
removing or installing
heavy components.

©



WARNING
Remain clear of lift
when raising or
lowering vehicle.

©



WARNING
Avoid excessive
rocking of vehicle
while on lift.

©



CAUTION
Use height extenders
when necessary
to ensure
good contact.

©



CAUTION
Auxiliary adapters
may reduce
load capacity.

©



WARNING
Do not override
self-closing
lift controls.

©



WARNING
Keep feet
clear of lift
while lowering.

©

The messages and pictographs shown are generic in nature and are meant to generally represent hazards common to all automotive lifts regardless of specific style.

Funding for the development and validation of these labels was provided by the Automotive Lift Institute, PO Box 33116 Indialantic, FL. 32903.

They are protected by copyright. Set of labels may be obtained from ALI or its member companies.

© 1992 by ALI, Inc.

ALI/WL101c

The messages and pictographs shown are generic in nature and are meant to generally represent hazards common to all automotive lifts regardless of specific style.

Funding for the development and validation of these labels was provided by the Automotive Lift Institute, PO Box 33116 Indialantic, FL. 32903.

They are protected by copyright. Set of labels may be obtained from ALI or its member companies.

© 1992 by ALI, Inc.

ALI/WL101w

Safe Lift Operation

Automotive and truck lifts are critical to the operation and profitability of your business. The safe use of this and other lifts in your shop is critical in preventing employee injuries and damage to customers' vehicles. Safe operation of automotive lifts requires that only trained employees should be allowed to use the lift.

TRAINING SHOULD INCLUDE, BUT NOT LIMITED TO:

- ◆ Proper positioning of the vehicle on the lift arms. (See manufacturer's minimum wheel base loading requirements.)
- ◆ Use of the operating controls.
- ◆ Understanding the lift capacity.
- ◆ Proper use of jack stands or other load supporting devices.
- ◆ Proper use, understanding and visual identification of safety lock devices and their operation.
- ◆ Reviewing the safety rules.
- ◆ Proper housekeeping procedures (lift area should be free of grease, oil, tools, equipment, trash, and other debris).
- ◆ A daily inspection of the lift should be completed prior to its use. Safety devices, operating controls, lift arms and other critical parts should be inspected prior to using the lift.
- ◆ All maintenance and repairs of the lift should be completed by following the manufacturer's requirements. Lift repair parts should meet or exceed OEM specifications. Repairs should only be completed by a qualified lift technician.
- ◆ The vehicle manufacturer's recommendations should be used for spotting and lifting the vehicle.

LIFT OPERATION / SAFETY

- ◆ It is important that you know the load limit. Be careful that you do not overload the lift. If you are unsure what the load limit is, check the data plate found on one of the lift columns or contact the manufacturer.
- ◆ The center of gravity should be followed closely to what the manufacturer recommends.
- ◆ Always make sure you have proper overhead clearance. Additionally, check that attachments (vehicle signs, campers, antennas, etc.) are not in the way.
- ◆ Be sure that prior to the vehicle being raised, the doors, trunk, and hood are closed securely.
- ◆ Prior to being raised, make sure there is no one standing closer than six feet from the lift.
- ◆ After positioning the vehicle on the lift runways, set the emergency brake, make sure the ignition is off, the doors are closed, overhead obstructions are cleared, and the transmission is in neutral.
- ◆ Double check that the automatic chock devices are in position and then when the lift is raised, observe the chocks.
- ◆ Put pads or adapters in the right position under the contact points that have been recommended.
- ◆ The lift should be raised just until the vehicle's wheels are about one foot off the ground. If contact with the vehicle is uneven or it appears that the vehicle is not sitting secure, carefully lower the lift and readjust.
- ◆ Always consider potential problems that might cause a vehicle to slip, i.e., heavy cargo, undercoating, etc.
- ◆ Pay attention when walking under a vehicle that is up on the hydraulic lift.



- ◆ **DO NOT** leave the controls while the lift is still in motion.
- ◆ **DO NOT** stand directly in front of the vehicle or in the bay when vehicle is being loaded or driven into position.
- ◆ **DO NOT** go near vehicle or attempt to work on the vehicle when being raised or lowered.
- ◆ **REMAIN CLEAR** of lift when raising or lowering vehicle.
- ◆ **DO NOT** rock the vehicle while on the lift or remove any heavy component from vehicle that may cause excessive weight shift.
- ◆ **DO NOT** lower the vehicle until people, materials, and tools are clear.
- ◆ **ALWAYS ENSURE** that the safeties are engaged and lowered on to the safeties before any attempt is made to work on or near vehicle.
- ◆ Some vehicle maintenance and repair activities may cause the vehicle to shift. Follow the manufacturer's guidelines when performing these operations. The use of jack stands or alternate lift points may be required when completing some repairs.
- ◆ **READ AND UNDERSTAND** all safety warning procedures before operating lift.
- ◆ **KEEP HANDS AND FEET CLEAR.** Remove hands and feet from any moving parts. Keep feet clear of lift when lowering. Avoid pinch points.
- ◆ **ONLY TRAINED OPERATORS** should operate this lift. All non-trained personnel should be kept away from work area. Never let non-trained personnel come in contact with, or operate lift.
- ◆ **USE LIFT CORRECTLY.** Use lift in the proper manner. Never use lifting adapters other than what is approved by the manufacturer.
- ◆ **DO NOT** override self-closing lift controls.
- ◆ **CLEAR AREA** if vehicle is in danger of falling.
- ◆ **STAY ALERT.** Watch what you are doing. Use common sense. Be aware.
- ◆ **CHECK FOR DAMAGED PARTS.** Check for alignment of moving parts, breakage of parts or any condition that may affect its operation. Do not use lift if any component is broken or damaged.
- ◆ **NEVER** remove safety related components from the lift. Do not use lift if safety related components are damaged or missing.
- ◆ When the lift is being lowered, make sure everyone is standing at least six feet away.
- ◆ Be sure there are no jacks, tools, equipment left under the lift before lowering.
- ◆ Always lower the vehicle down slowly and smoothly.

LIFT WILL NOT RAISE

POSSIBLE CAUSE

1. Air in oil, (1, 2, 8, 13)
2. Cylinder binding, (9)
3. Cylinder leaks internally, (9)
4. Motor run backward under pressure, (11)
5. Lowering valve leaks, (3, 4, 6, 10, 11)
6. Motor runs backwards, (7, 14, 11)
7. Pump damaged, (10, 11)
8. Pump won't prime, (1, 8, 13, 14, 3, 12, 10, 11)
9. Relief valve leaks, (10, 11)
10. Voltage to motor incorrect, (7, 14, 11)

REMEDY

INSTRUCTION

- | | |
|-----------------------------------------------------------------------|-------------------------------------------------------------------------------------------------------|
| 1. Check for proper oil level. | The oil level should be up to the bleed screw in the reservoir with the lift all the way down. |
| 2. Bleed cylinders. | See Installation Manual |
| 3. Flush release valve to get rid of possible contamination | Hold release handle down and start unit allowing it to run for 15 seconds. |
| 4. Dirty oil. | .Replace oil with clean ATF fluids such as: Dexron III, Dexron VI, Mercon V, Mercon LV or comparable. |
| 5. Tighten all fasteners. | Tighten fasteners to recommended torques. |
| 6. Check for free movement of release. | If handle does not move freely, replace bracket or handle assembly. |
| 7. Check if motor is wired correctly. | .Compare wiring of motor to electrical diagram on drawing. |
| 8. Oil seal damaged or cocked | Replace oil seal around pump shaft. |
| 9. See Installation Manual | Contact BendPak Customer Support. |
| 10. Replace with new part | Replace with new part. |
| 11. Return unit for repair | Return unit for repair. |
| 12. Check pump-mounting bolts | Bolts should be tightened to 15 to 18 ft. lbs. |
| 13. Inlet screen clogged | Clean inlet screen or replace. |
| 14. Check wall outlet voltages and wiring | Make sure unit and wall outlet are wired properly. |

MOTOR WILL NOT RUN

POSSIBLE CAUSE

1. Fuse blown, (5, 2, 1, 3, 4)
2. Limit switch burned out, (1, 2, 3, 4)
3. Microswitch burned out, (1, 2, 3, 4)
4. Motor burned out, (1, 2, 3, 4, 6)
5. Voltage to motor incorrect, (2, 1, 8)

REMEDY

- | REMEDY | INSTRUCTION |
|---------------------------------------------------|------------------------------------------------------------------------------------------------------------------------------------------------------------------------------------------------------------------|
| 1. Check for correct voltage | .Compare supply voltage with voltage on motor name tag. Check that the wire is sized correctly. N.E.C. table 310-12 requires AWG 10 for 25 Amps. |
| 2. Check motor is wired correctly | .Compare wiring of motor to electrical diagram on drawing. |
| 3. Don't use extension cords | .According to N.E.C.: "The size of the conductors... should be such that the voltage drop would not exceed 3% to the farthest outlet for power..." Do not run motor at 115 VAC – damage to the motor will occur. |
| 4. Replace with new part | .Replace with new part. |
| 5. Reset circuit breaker/fuse | .Reset circuit breaker/fuse. |
| 6. Return unit for repair | Return unit for repair. |
| 7. See Installation Manual | .See Installation Manual. |
| 8. Check wall outlet voltage and wiring | Make sure unit and wall outlet is wired properly. Motor must run at 208/230 VAC. |

LIFT LOWERS SLOWLY OR NOT AT ALL

POSSIBLE CAUSE

1. Cylinders binding, (1)
2. Release valve clogged, (5,4,2,3)
3. Pressure fitting too long, (6)

REMEDY

- | REMEDY | INSTRUCTION |
|-----------------------------------------------------|---------------------------------------------------------------------------------------------------------------------------------------------------------------------------------|
| 1. See Installation Manual | Contact BendPak Customer Support. |
| 2. Replace with new part | Replace with new part. |
| 3. Return for repair | Return for repair. |
| 4. Check oil. | Use clean 10-WT hydraulic oil, Dexron-III, Dexron VI, Mercon V, Mercon LV automatic transmission fluid. If ATF is contaminated, replace with clean ATF and clean entire system. |
| 5. Clean release valve | Wash release valve in solvent and blow out with air. |
| 6. Replace fitting with short thread lead | Replace fitting with short thread lead. |

WILL NOT RAISE LOADED LIFT

POSSIBLE CAUSE

1. Air in oil, (1,2,3,4)
2. Cylinder binding, (5)
3. Cylinder leaks internally, (5)
4. Lift overloaded, (6,5)
5. Lowering valve leaks, (7,8,1,5,9)
6. Motor runs backwards, (10,12,9)
7. Pump damaged, (5,9)
8. Pump won't prime, (1,2,3,4,5,11,9)
9. Relief valve leaks, (8,5,9)
10. Voltage to motor incorrect, (10,12,5)

REMEDY

- | REMEDY | INSTRUCTION |
|----------------------------------------------------|------------------------------------------------------------------------------------------------|
| 1. Check oil level | The oil level should be up to the bleed screw in the reservoir with the lift all the way down. |
| 2. Check/Tighten inlet tubes | Replace inlet hose assembly. |
| 3. Oil seal damaged or cocked | Replace oil seal and install. |
| 4. Bleed cylinders | See Installation Manual. |
| 5. See Installation Manual | Contact BendPak Customer Support. |
| 6. Check vehicle weight | Compare weight of vehicle to weight limit of the lift. |
| 7. Flush release valve | Hold release handle down and start unit allowing it to run for 15 seconds. |
| 8. Replace with new part | Replace with new part. |
| 9. Return unit for repair | Return unit for repair. |
| 10. Check motor is wired correctly | Compare wiring of motor to electrical diagram on power unit drawing. |
| 11. Inlet screen clogged | Clean inlet screen or replace. |
| 12. Check wall outlet voltage and wiring | Make sure unit and wall outlet is wired properly. |

INSTRUCTION

IMPORTANT

If a vehicle becomes stranded in the air, follow all operation instructions as shown on pages 40, 42 and 48. If after observing that all mechanical locks are released and the lift still fails to move following all standard operating procedures, immediately stop using the lift and contact factory or factory approved service center for further instructions.

LIFT WILL NOT STAY UP

POSSIBLE CAUSE





1. Air in oil, (1, 2, 3)
2. Check valve leaks, (6)
3. Cylinders leak internally, (7)
4. Lowering valve leaks, (4, 5, 1, 7, 6)
5. Leaking fittings, (8)

REMEDY

1. Check oil level The oil level should be up to the bleed screw in the reservoir with the lift all the way down.
2. Oil seal damaged and cocked Replace oil seal around pump shaft.
3. Bleed cylinder Refer to Installation Manual.
4. Flush release valve Hold release handle down and start unit allowing it to run for 15 seconds.
5. Replace with new valve Replace with new valve.
6. Return unit for repair Return unit for repair.
7. See Installation Manual Contact BendPak Customer Support.
8. Check complete hydraulic system for leaks. Tighten all hydraulics fittings and inspects all hoses.

INSTRUCTION

Torque Recommendations

VALUES ARE STATED IN FOOT POUNDS (ft-lb)					
					
		SAE 0-1-2	SAE Grade 5	SAE Grade 8	SOCKET HEAD CAP SCREW
		CLASS 4.8	CLASS 8.8	CLASS 10.9	CLASS 12.9
Bolt Size (SAE)	Bolt Size (Metric)				
1/4-20	M6 x 1.0	6	10	14	13
5/16-18	M8 x 1.25	12	19	29	31.4
3/8-16	M10 x 1.50	20	33	47	62
7/16-14		32	54	78	
1/2-13	M12 x 1.75	47	78	119	108
9/16-12	M14 x 2.00	69	114	169	173
5/8-11	M16 x 2.00	96	154	230	269
3/4-10	M18 x 2.50	155	257	380	372
7/8-9	M22 x 2.50	206	382	600	716
3/4 Anchor Bolts		75 MIN 110 MAX			

INSTALLATION FORM

Customer Name:		Date of Installation:
Company Name:		
Street Address:		
City:	State:	Zip:
Phone:	Fax:	

Pre-Install Agreement

I, (the undersigned) acting as the owner of the business listed above assume responsibility for any permits required, either state or county mandated, related to the installation and/or operation of this equipment. I assume responsibility for the concrete floor and condition thereof, now or later, where the above equipment model(s) are installed. I will assume all liability for losses, damages (including loss of use), expenses, demands, claims, and judgments in connection with or arising out of any personal injury or alleged damage to property, sustained or alleged to have been sustained in connection with, or to have arisen out of the condition and/or drilling of the concrete near or adjacent to the equipment model(s) listed above. If my employee(s) offer assistance of any kind during installation of the above equipment model(s) I hold the manufacturer and installation company harmless of all liability for losses, damages, expenses, claims, and judgments in connection with or arising out of any personal injury or alleged damage to property, sustained or alleged to have been sustained in connection with the installation of the above equipment model(s).

I understand that the lifts above are supplied with concrete fasteners meeting the criteria of the American National Standard "Automotive Lifts - Safety Requirements for Construction, Testing, and Validation" ANSI/ALI ALCTV-1998, and that I will be responsible for all charges related to any special regional structural and/or seismic anchoring requirements specified by any other agencies and/or codes such as the Uniform Building Code (UBC) and/or International Building Code (IBC).

Customer Signature: _____ Print Name: _____ Date: _____

Post-Installation Check-Off

- | | |
|-----------------------------------------------------------------------|-----------------------------------------------------------------------------|
| <input type="checkbox"/> Base and Columns Properly Shimmed And Stable | <input type="checkbox"/> Lubrication of Critical Components |
| <input type="checkbox"/> Anchor Bolts Tightened | <input type="checkbox"/> Lift Adapters |
| <input type="checkbox"/> Runways Properly Attached and Secured | <input type="checkbox"/> Check For Overhead Obstructions |
| <input type="checkbox"/> Electric Power Supply Confirmed | <input type="checkbox"/> Runways Level |
| <input type="checkbox"/> Cables / Chains Adjusted Properly | <input type="checkbox"/> All Screws, Bolts, and Pins Secured |
| <input type="checkbox"/> Safety Locks Functioning Properly | <input type="checkbox"/> Surrounding Area and Lift Clean In Appearance |
| <input type="checkbox"/> Check For Hydraulic Leaks | <input type="checkbox"/> Proper Operation, Maintenance and Safety Explained |
| <input type="checkbox"/> Oil Level | <input type="checkbox"/> Operation and Safety Manual(s) Left at Site |

I, (the undersigned) confirm that the above installation procedure(s) were completed. I understand that I will be responsible for maintaining this equipment as outlined in the accompanied **Installation and Operation Manual** and **ANSI/ALI ALOIM Safety Requirements for Operation, Inspection and Maintenance**. I understand that personal injury and/or damage to property can occur if the above equipment model(s) are not maintained or used improperly and take full responsibility for training my employees on proper use and maintenance of this equipment. I hold the manufacturer and installation company harmless of all liability for losses, damages (including loss of use), expenses, demands, claims, and judgments in connection with or related to improper use, improper training, or lack of required maintenance. I understand that the warranty does not cover replacement of parts worn or damaged due to normal use or lack of required maintenance

Customer Signature: _____ Print Name: _____ Date: _____

Installer Signature: _____ Print Name: _____ Date: _____

Installer Company Name: _____

Street Address: _____

City:	State:	Zip:
Phone:	Phone (Other):	

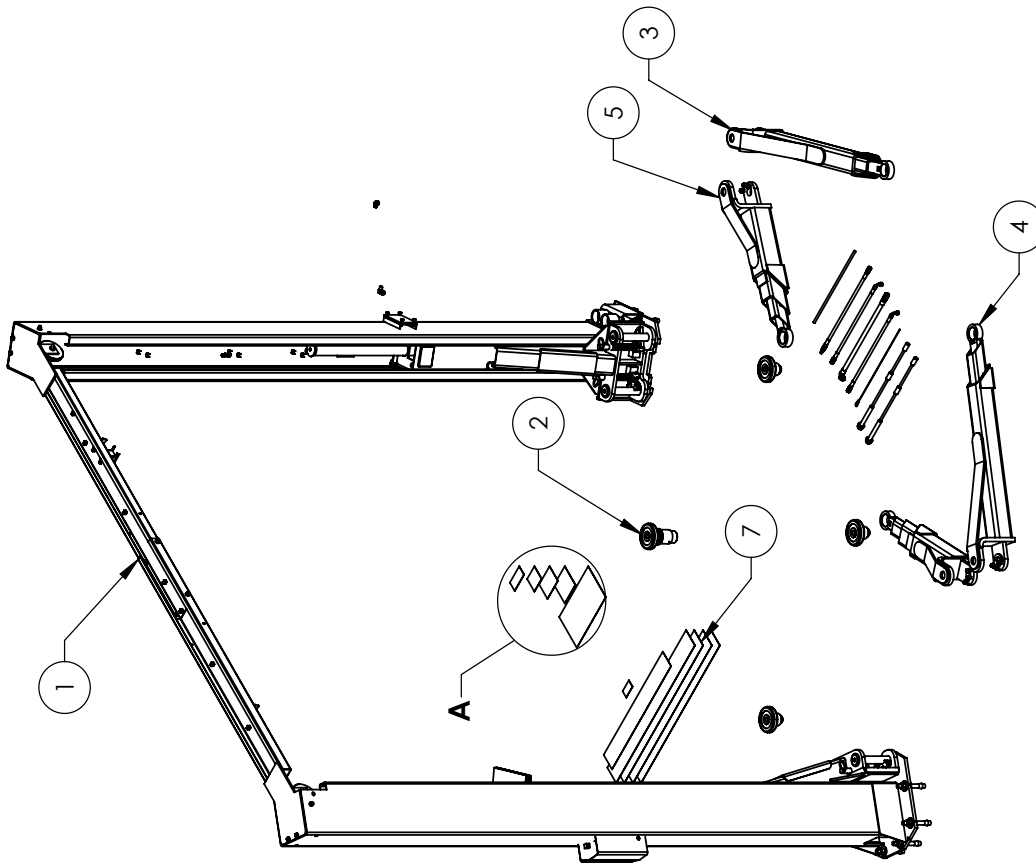

DETAIL A
SCALE 1 : 12

ITEM NO	PART NUMBER	DESCRIPTION	QTY	REV
1	5245044	XPR-10A LIFT SUPERSTRUCTURE	1	D
2	5250039	XPR-10AS PIVOT ROY	1	A
3	5213286	XPR-10A LOW PROFILE LONG ARM ASSEMBLY, R.H.	1	C
4	5213285	XPR-10A LOW PROFILE LONG ARM ASSEMBLY, L.H.	1	C
5	5215284	XPR-10AS LOW PROFILE TRIPLE TELESCOPING ARM ASSEMBLY	2	C
6	5905109	WARNING ALI/WL 101	1	-
7	5905131	2 POST DECAL KIT, LESS ALL	1	C
8	5905403	MAX CAP DANGER TOK	1	-
9	5905465	MANUFACTURER LABEL	1	-
10	5905940	PRODUCT DATA LABEL	1	-
11	5905950	2015_SERIAL_TAG-A-5905950	1	-

BendPak
1645 LEMONWOOD DR.
SANTA PAULA, CA 93060

TITLE: XPR-10AS PRODUCTION
LIFT VER F

SIZE DWG. NO. A 5260562 REV A

SCALE: 1:35 SHEET 1 OF 2



ITEM NO	PART NUMBER	DESCRIPTION	QTY	REV
1	5174518	XPR CLEARFLOOR PARTS BAG	1	J
2	5505116	XPR-9/10 LIFT HEAD PIN WELDMENT	4	D
3	5595073	XPR-10A CABLE ASSEMBLY Ø10 x 9999mm DBST	1	B
4	5595072	XPR-10A CABLE ASSEMBLY Ø10 x 10115mm DBST	1	B
5	5570832	XPR CLEARFLOOR HYDRAULIC HOSE ASSY Ø6.35 x 2299mm SB	1	E
6	5570017	XPR HYDRAULIC HOSE ASSY Ø10 x 1219mm SB	1	C
7	5595047	XPR-10/10A Ø24 x 7747 SAFETY CABLE	1	F
8	5570058	XPR-10A HYDRAULIC HOSE ASSY Ø6.35 x 8090 SB	1	B
9	5570065	XPR-10A HYDRAULIC HOSE EXTENSION ASSY Ø6.35 x 203mm DS	1	C
10	5210007	XPR POWER SIDE SAFETY ASSEMBLY	1	F
11	5210010	XPR OFF SIDE SAFETY WELDMENT	1	F
12	5715003	POWER UNIT VIBRATION DAMPENER	1	B
13	5215704	ROUND ADJUSTABLE LIFT PAD ASSEMBLY	4	B
14	5601058	XPR-10 SERIES POST ASSEMBLY LIFT HEAD FOOT GUARD	2	A
15	5736604	TWO POST LIGHT DUTY BOLT ON ARM RESTRAINT GEAR	4	E
16	5600163	XPR CLEARFLOOR POWER SIDE SAFETY COVER	1	E
17	5210009	XPR-9D/10/12/12FD/15/18C OFF SIDE SAFETY COVER	1	E
18	5746192	ARM ADAPTER, MEDIUM	4	C
19	5545342	WASHER M18 FLAT	2	-
20	5535358	NUT M18 x 2.5 NL	2	-
21	5540281	C RING Ø38mm OD-5103-150	4	-
22	5746167	DOUBLE THREADED ROD M10 x 1.5 x 27.5	2	B
23	5716634	XPR MICROSWITCH COVER, PLASTIC	1	A
24	5550095	FIG NPL -04 JIC X-04 JIC	1	-
25	5530307	AB 3/4" x 5"	12	-
26	5525150	SPDT MICRO SWITCH:25A@125VAC	1	-
27	5525112	MICRO SWITCH COVER-5PA2	1	-
28	5520116	14-4 SJO UL 62 CABLE 300VAC	3635mm*	-
29	5905151	SAFETY TIPS CARD ALLST 90	1	-
30	5900147	SAFETY MANUAL ALL/SM/93-1	1	-
31	5900152	ALIGN OIM OPERATION INSPECTION & MAINTENANCE	1	-
32	5900280	ALI/1P FRAME ENGAGING LIFTS GUIDE	1	-
33	5900958	XPR-10 CE INSTALLATION MANUAL	1	-

BendPak
1645 LEMONWOOD DR.
SANTA PAULA, CA 93060

TITLE: XPR-10AS PARTS BOX

SIZE (DWG. NO.)
A 5250039

REV
A

SCALE: 1:35

SHEET 1 OF 2

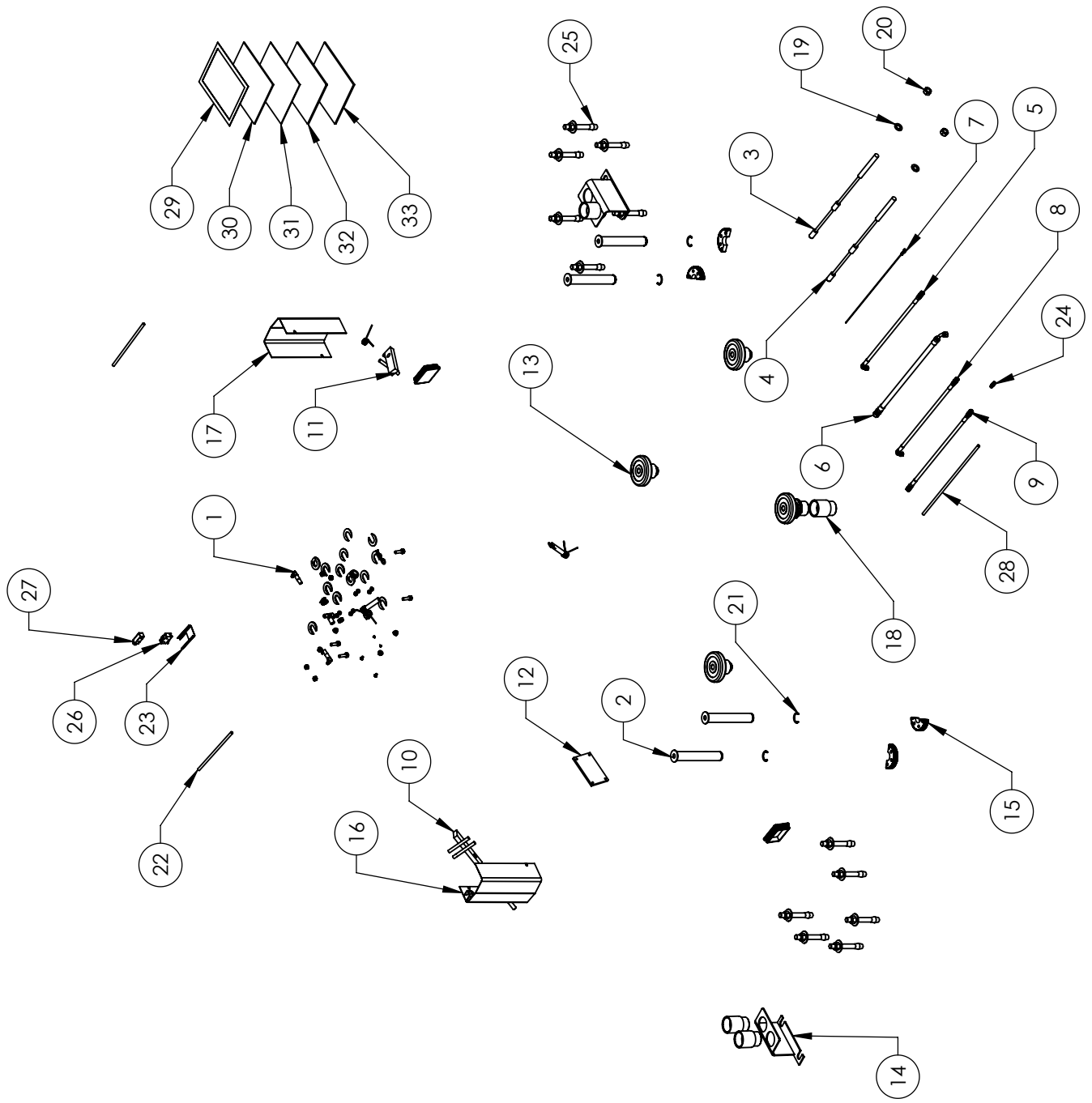

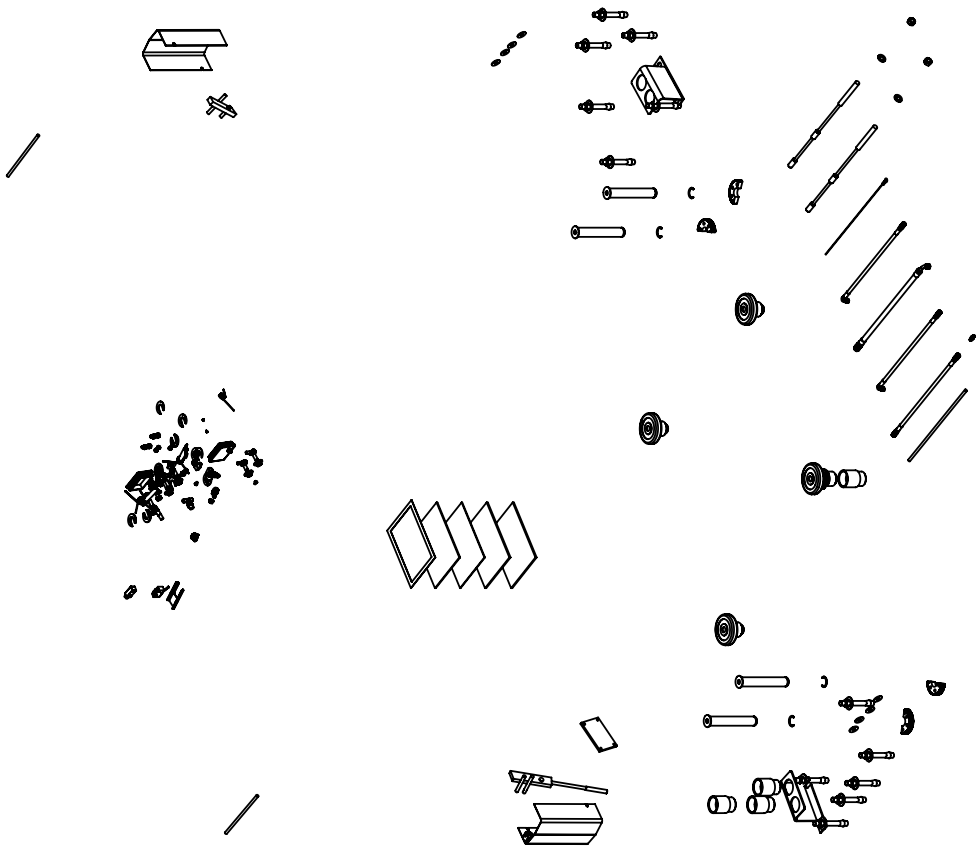

ITEM NO	PART NUMBER	DESCRIPTION	QTY	REV
1	5174218	XPR CLEARFLOOR EXTENDED PARTS BAG	1	J
2	5505116	XPR-9/10 LIFT HEAD PIN WELDMENT	4	D
3	5595837	XPR-10A EXTENDED CABLE ASSY Ø10 x 11219mm DBST	1	B
4	5595923	XPR-10A EXTENDED CABLE ASSY Ø10 x 11335mm DBST	1	B
5	5570065	XPR-10A HYDRAULIC HOSE EXTENSION ASSY Ø6.35 x 203mm DS	1	C
6	5570832	XPR CLEARFLOOR HYDRAULIC HOSE ASSY Ø6.35 x 299mm SB	1	E
7	5570017	XPR HYDRAULIC HOSE ASSY Ø10 x 1219mm SB	1	C
8	5595104	XPR-10/10A EXTENDED Ø2.4 X 8839 SAFETY CABLE	1	E
9	5570059	XPR-10A EXTENDED HYDRAULIC HOSE ASSY Ø6.35 x 9308 SB	1	B
10	5210007	XPR POWER SIDE SAFETY ASSEMBLY	1	F
11	5210010	XPR OFF SIDE SAFETY WELDMENT	1	F
12	5715003	POWER UNIT VIBRATION DAMPENER	1	E
13	5215704	ROUND ADJUSTABLE LIFT PAD ASSEMBLY	4	B
14	5601058	XPR-10 SERIES POST ASSEMBLY LIFT HEAD FOOT GUARD	2	A
15	5736604	TWO POST LIGHT DUTY BOLT ON ARM RESTRAINT GEAR	4	E
16	5600163	XPR CLEARFLOOR POWER SIDE SAFETY COVER	1	E
17	5210009	XPR-9D/10/12/12ED/15/18C OFF SIDE SAFETY COVER	1	E
18	5746192	ARM ADAPTER-MEDIUM	4	C
19	5545342	WASHER M18 FLAT	2	--
20	5535358	NUT M18 x 2.5 NL	2	--
21	5540281	C RING Ø38mm OD 5103-150	4	--
22	5746167	DOUBLE THREADED ROD M10 x 1.5 x 275	2	B
23	5716634	XPR MICRO SWITCH COVER-PLASTIC	1	A
24	5550095	FIG NPL-04 JIC X-04 JIC	1	--
25	5530307	AB 3/4" x 5"	12	--
26	5905151	SAFETY TRS CARD A11ST 90	1	--
27	5900147	SAFETY MANUAL A11/SM 93-1	1	--
28	5900152	ALIGN OIM OPERATION INSPECTION & MAINTENANCE	1	--
29	5900280	ALI/LP FRAME ENGAGING LIFTS GUIDE	1	--
30	5900958	XPR-10 CE INSTALLATION MANUAL	1	G
31	5525150	SPDT MICRO SWITCH-25A@125VAC	1	A
32	5525112	MICRO SWITCH COVER-SPA2	1	A
33	5520116	14-4 S10 UL 62 CABLE 300YGC	4275mm*	A

BendPak 1645 LEMONWOOD DR.
SANTA PAULA, CA 93060

TITLE: XPR-10AS EXTENDED PARTS BOX

SIZE DWG. NO. **A** 5250040 REV **A**



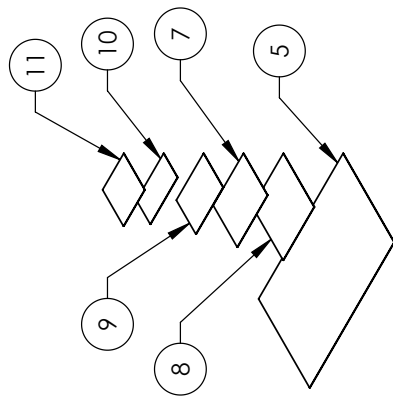
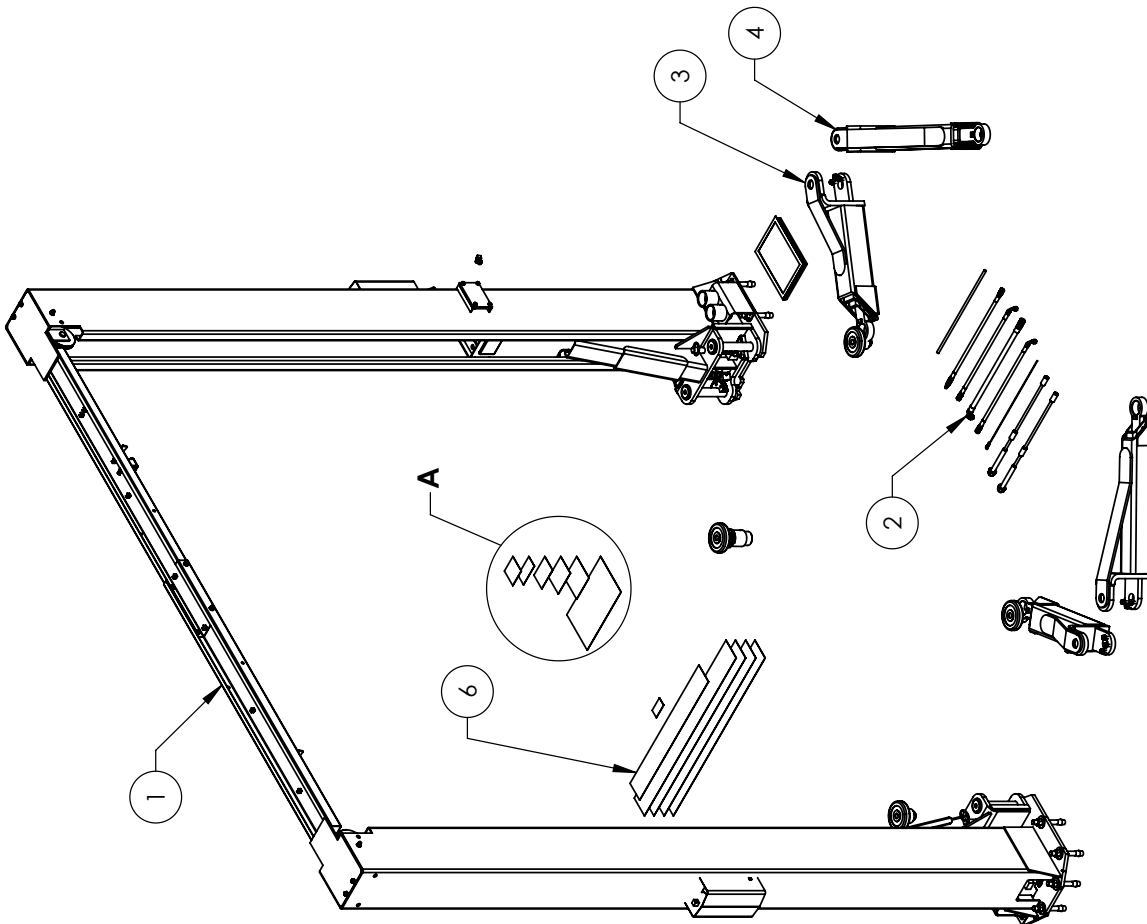

DETAIL A
SCALE 1 : 12

ITEM NO	PART NUMBER	DESCRIPTION	QTY	REV
1	5245227	XPR-10 LIFT SUPERSTRUCTURE	1	R
2	5250048	XPR-10S PARTS BOX	1	A
3	5215287	XPR-9S/9DS/10S LOW PROFILE TRIPLE TELESCOPING ARM ASSEMBLY	2	C
4	5215700	XPR-9S/9DS/10S LOW PROFILE MEDIUM ARM ASSEMBLY	2	C
5	5905109	WARNING ALI/WL 101	1	C
6	5905131	2 POST DECAL KILLESS ALI	1	C
7	5905403	MAX CAP DANGER TOK	1	---
8	5905465	MANUFACTURER LABEL	1	---
9	5905655	MAX CAP NRTL DANGER TOK	1	---
10	5905940	PRODUCT DATA LABEL	1	---
11	5905950	2015 SERIAL TAG-A-5905950	1	---

BendPak 1645 LEMONWOOD DR.
SANTA PAULA, CA 93060

TITLE: XPR-10S PRODUCTION
LIFT VER E

SIZE DWG. NO. **A** 5260575 REV **A**

SCALE: 1:30 SHEET 1 OF 2

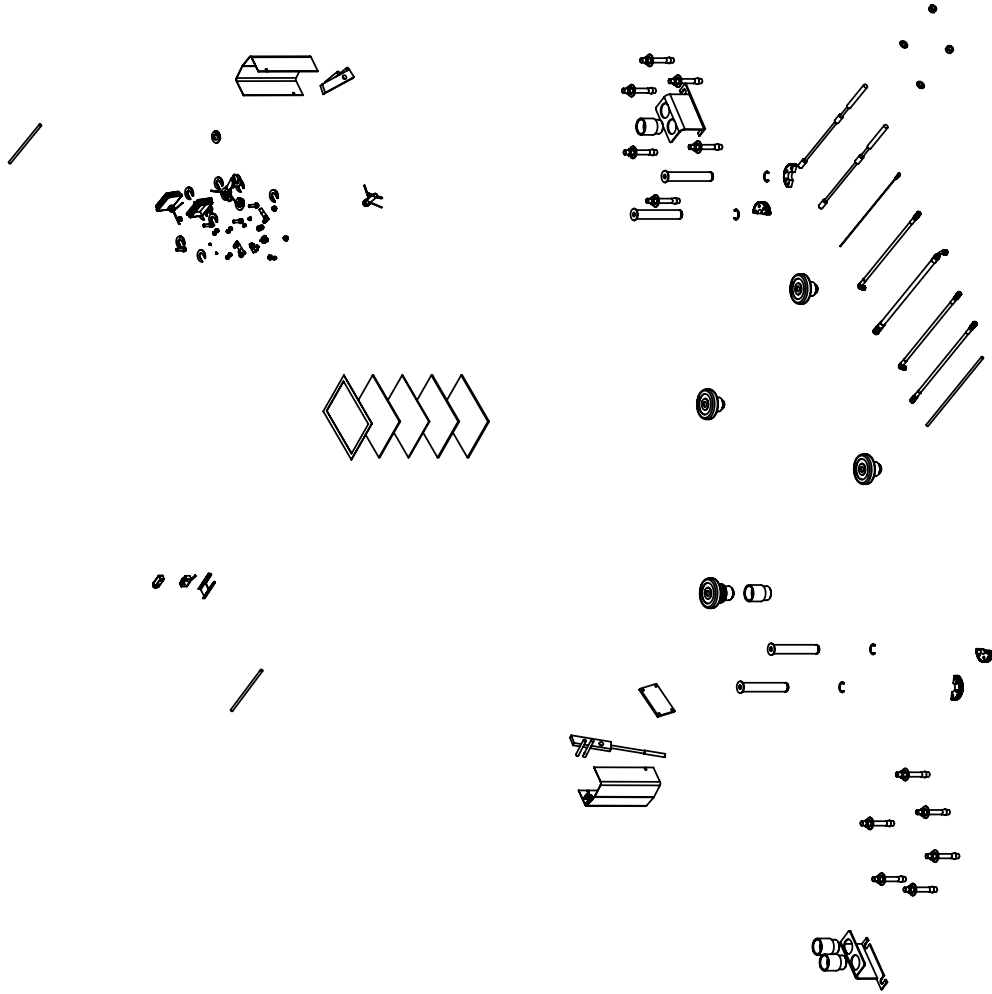

ITEM NO	PART NUMBER	DESCRIPTION	QTY	REV
1	5174518	XPR CLEARFLOOR PARTS BAG	1	J
2	5505116	XPR-9/10 LIFT HEAD PIN WELDMENT	4	D
3	5595367	XPR-10 CABLE ASSEMBLY Ø10 x 1007.6mm DBST	2	A
4	5570832	XPR CLEARFLOOR HYDRAULIC HOSE ASSY Ø6.35 x 2299mm SB	1	E
5	5570017	XPR HYDRAULIC HOSE ASSY 10 x 1219mm SB	1	C
6	5595047	XPR-10/10A Ø2.4 x 7747 SAFETY CABLE	1	E
7	5570038	XPR-10 HYDRAULIC HOSE ASSY Ø6.35 x 801.5 SB	1	F
8	5210007	XPR POWER SIDE SAFETY ASSEMBLY	1	F
9	5210010	XPR OFF SIDE SAFETY WELDMENT	1	E
10	5715003	POWER UNIT VIBRATION DAMPENER	1	B
11	5215704	ROUND ADJUSTABLE LIFT PAD ASSEMBLY	4	B
12	5601058	XPR-10 SERIES POST ASSEMBLY LIFT HEAD FOOT GUARD	2	A
13	5736604	TWO POST LIGHT DUTY BOLT ON ARM RESTRAINT GEAR	4	E
14	5600163	XPR CLEARFLOOR POWER SIDE SAFETY COVER	4	E
15	5210009	XPR-9D/10/12/12FD/15/18C OFF SIDE SAFETY COVER	1	E
16	5746192	ARM ADAPTER, MEDIUM	4	C
17	5545342	WASHER M18 FLAT	2	-
18	5535358	NUT M18 x 2.5 NL	2	-
19	5540281	C RING Ø38mm OD 5103-150	4	-
20	5546167	DOUBLE THREADED ROD M10 x 1.5 x 275	2	B
21	5716634	XPR MICROSWITCH COVER PLASTIC	2	A
22	5570176	XPR-9D/10 HYDRAULIC HOSE EXTENSION ASSY Ø6.35 x 330mm DS	1	D
23	5550095	FIG NPL-04 JIC X-04 JIC	1	-
24	5530307	AB 374" x 5"	12	-
25	5905151	SAFETY TIPS CARD AL1-ST 90	-	-
26	5900147	SAFETY MANUAL AL1/SM 93-1	-	-
27	5900152	ALIGN OIM OPERATION INSPECTION & MAINTENANCE	1	-
28	5900280	ALI/PL FRAME ENGAGING LIFTS GUIDE	1	-
29	5900958	XPR-10 CE INSTALLATION MANUAL	1	-
30	5525150	SPDT MICRO SWITCH 25A@125VAC	1	-
31	5525112	MICRO SWITCH COVER 5PA2	1	-
32	5520116	14-4 SJO UL 62 CABLE 300VAC	3635mm*	-

BendPak 1645 LEMONWOOD DR.
SANTA PAULA, CA 93060

TITLE: XPR-10S PARTS BOX

SIZE DWG. NO. **A** 5250048 REV **A**

SCALE: 1:30 SHEET 1 OF 2

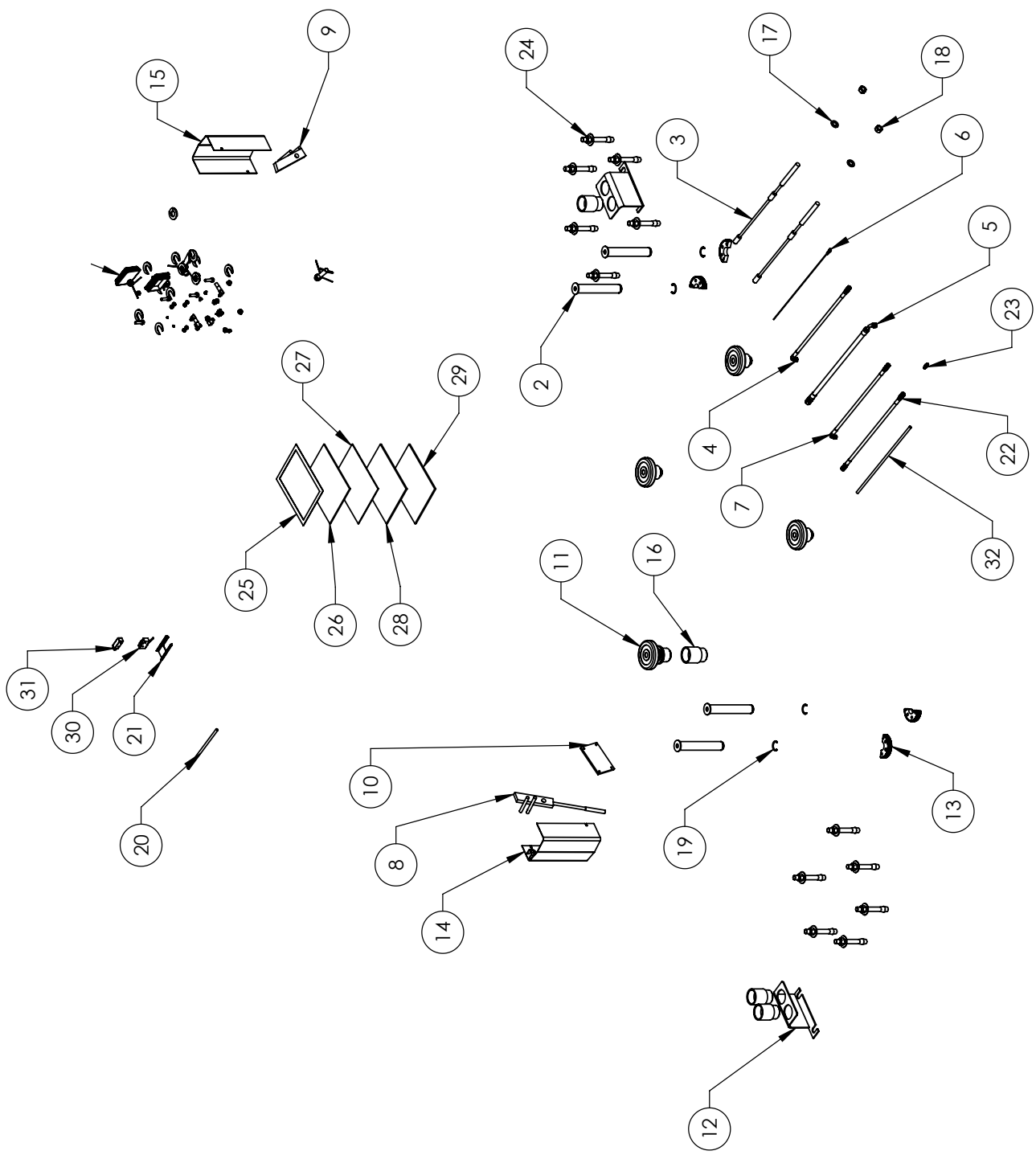

• 1
• 1

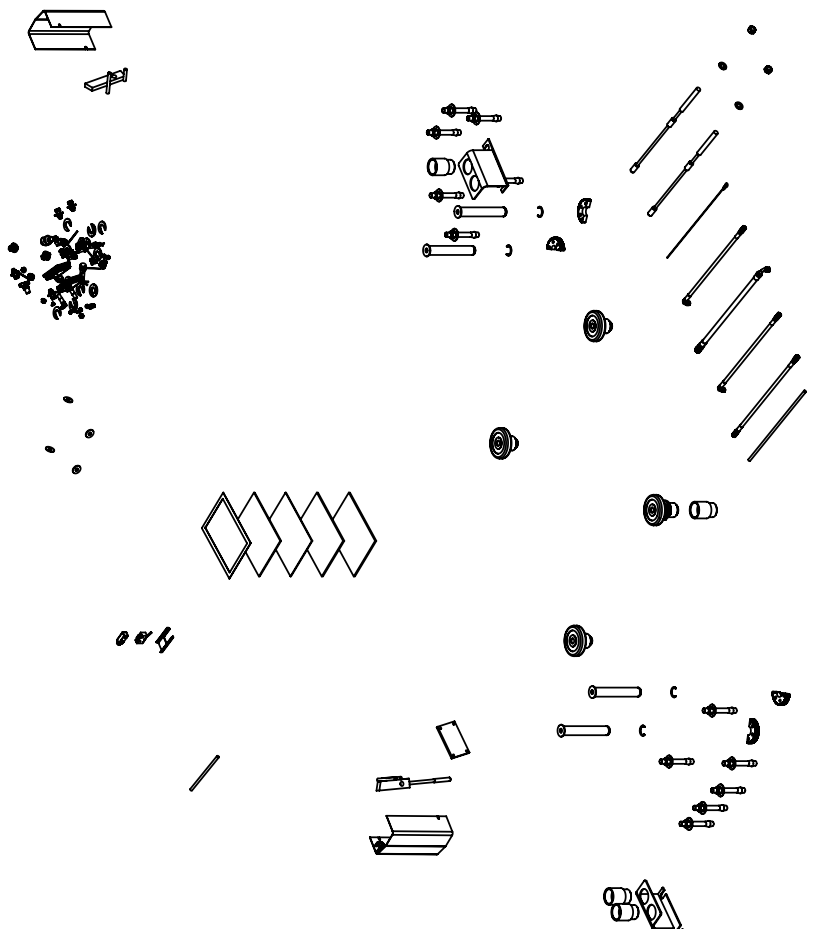

ITEM NO	PART NUMBER	DESCRIPTION	QTY	REV
1	5174218	XPR CLEARFLOOR EXTENDED PARTS BAG	1	J
2	5505116	XPR-9710 LIFT HEAD PIN WEDMENT	4	D
3	5595368	XPR-10 EXTENDED CABLE ASSY Ø10 x 11296mm DBST	2	A
4	5570832	XPR CLEARFLOOR HYDRAULIC HOSE ASSY Ø6.35 x 2299mm SB	1	E
5	5570017	XPR HYDRAULIC HOSE ASSY Ø10 x 1219mm SB	1	C
6	5595104	XPR-10/10A EXTENDED Ø2.4 x 8839 SAFETY CABLE	1	E
7	5570005	XPR-10 EXTENDED HYDRAULIC HOSE ASSY Ø6.35 x 9283 SB	1	E
8	5210007	XPR POWER SIDE SAFETY ASSEMBLY	1	F
9	5210010	XPR OFF SIDE SAFETY WELDMENT	1	F
10	5715003	POWER UNIT VIBRATION DAMPENER	1	B
11	5215704	ROUND ADJUSTABLE LIFT PAD ASSEMBLY	4	B
12	5601058	XPR-10 SERIES POST ASSEMBLY LIFT HEAD FOOT GUARD	2	A
13	5736604	TWO POST LIGHT DUTY BOLT ON ARM RESTRAINT GEAR	4	E
14	5600163	XPR CLEARFLOOR POWER SIDE SAFETY COVER	1	F
15	5210009	XPR-9D/10/12/12FD/1578C OFF SIDE SAFETY COVER	1	F
16	5746197	ARM W/ADAPTER MEDIUM	4	C
17	5574634	WASHER M18x14	2	-
18	5574636	NUT M18 x 7.5 N	2	-
19	5574637	C RING Ø38mm OD 5103-150	2	-
20	5746167	DOUBLE THREADED ROD M10 x L5 x 275	4	B
21	5525150	SPDT MICRO SWITCH 2SA@125VAC	1	-
22	5525112	MICRO SWITCH COVER 5PA2	1	-
23	5520116	4-4 SJ UL 62 CABLE 300VGC	4275mm*	-
24	5716634	XPR MICRO SWITCH COVER PLASTIC	1	A
25	5570176	XPR-9D/10 HYDRAULIC HOSE EXTENSION ASSY Ø6.35 x 330mm DS	1	D
26	5550095	FIG NPL-04 JIC x-04 JIC	1	-
27	5530307	AB 374" x 5"	12	-
28	5905151	SAFETY TIPS CARD ALL-ST 90	1	-
29	5900147	SAFETY MANUAL ALL SM 93-1	1	-
30	5900152	ALIGN OIM OPERATION INSPECTION & MAINTENANCE	1	-
31	5900280	ALU IP FRAM ENGAGING LIFTS GUIDE	1	-
32	5900958	XPR-10 CE INSTALLATION MANUAL	1	-

BendPak
1645 LEMONWOOD DR.
SANTA PAULA, CA 93060

TITLE: XPR-10S EXTENDED PARTS BOX

SIZE DWG. NO. **A** 5250049 REV **A**

SCALE: 1:30 SHEET 1 OF 2

1645 LEMONWOOD DR. SANTA PAULA, CA 93060	
TITLE:	XPR-10S EXTENDED PARTS BOX
SIZE DWG. NO.	A 5250049
REV	A



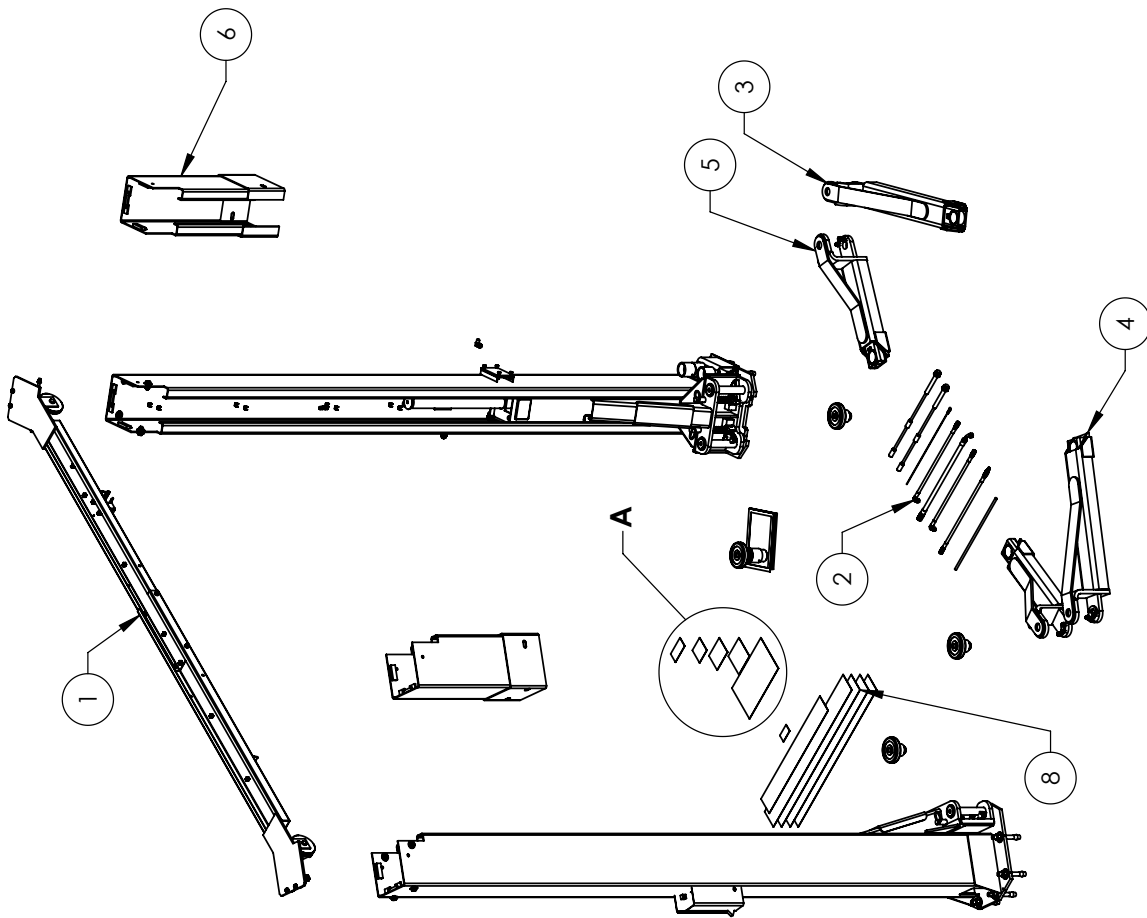

**DETAIL A
SCALE 1 : 12**

ITEM NO	PART NUMBER	DESCRIPTION	QTY	REV
1	5245044	XPR-10A LIFT SUPERSTRUCTURE	1	D
2	5250040	XPR-10AS EXTENDED PARTS BOX	1	A
3	5215278	XPR-10AS-1P LONG ARM ASSEMBLY R.H.	1	C
4	5215277	XPR-10AS-1P LONG ARM ASSEMBLY L.H.	1	C
5	5215276	XPR-10AS-1P SHORT ARM ASSEMBLY	2	C
6	5210259	XPR-10 POST EXTENSION WELDMENT	2	E
7	5805109	WARNING SIGN (10)	1	-
8	5805131	2 POST EXTENSION WELDMENT	2	-
9	5805103	POST EXTENSION WELDMENT	1	C
10	5805103	MAXIMUM DANGER SIGN	1	-
11	5805103	MANUFACTURER LABEL	1	-
12	5805240	PRODUCT DATA LABEL	1	-
		2015 SERIAL TAG-A-5905950	1	-



TITLE: XPR-10AS-168-LP PRODUCTION LIFT VER F	
SIZE DWG. NO. A	REV A
SCALE: 1:35	SHEET 1 OF 2

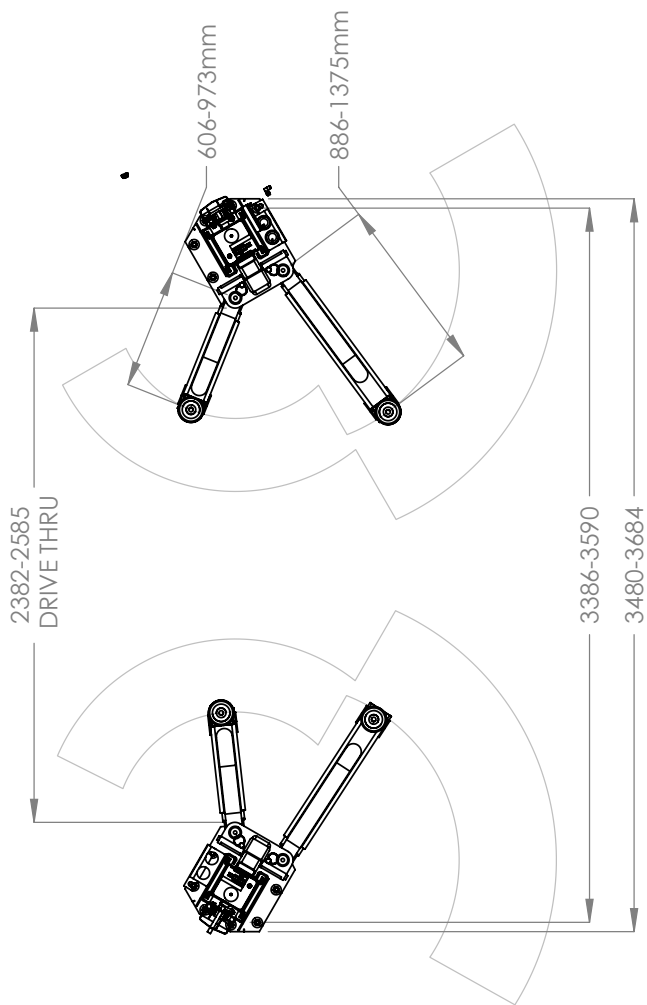

SECTION A-A
SCALE 1 : 35

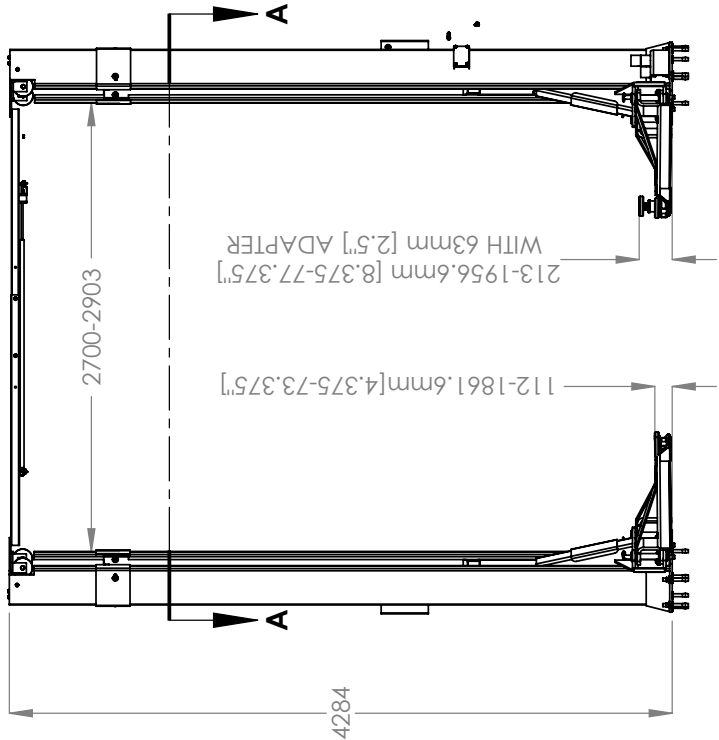

BendPak
1645 LEMONWOOD DR.
SANTA PAULA, CA 93060

TITLE:	XPR-10AS-168-LP PRODUCTION LIFT VER F		
SIZE:	DWG. NO.	REV	
A	5260559	A	
SCALE: 1:45			SHEET 2 OF 2

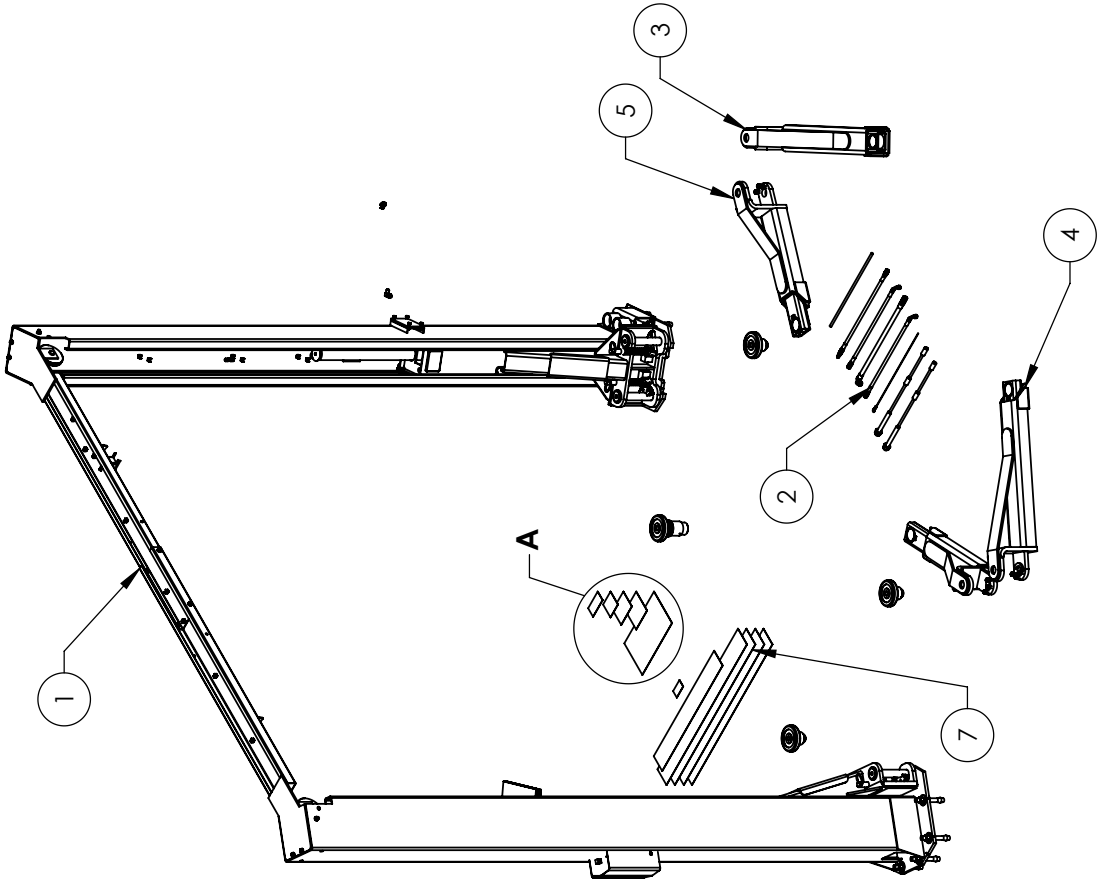

DETAIL A
SCALE 1 : 12

ITEM NO	PART NUMBER	DESCRIPTION	QTY	REV
1	5245044	XPR-10A LIFT SUPERSTRUCTURE	1	D
2	5250039	XPR-10AS PARTS BOX	1	A
3	5215278	XPR-10AS-LP LONG ARM ASSEMBLY, R.H.	1	C
4	5215277	XPR-10AS-LP LONG ARM ASSEMBLY, L.H.	1	C
5	5215276	XPR-10AS-LP SHORT ARM ASSEMBLY	2	C
6	5905109	WARNING ALI/WL 101	1	-
7	5905131	2 POST DECAL KIT, LESS ALL	1	C
8	5905403	MAX CAP DANGER 10K	1	-
9	5905465	MANUFACTURER LABEL	1	-
10	5905940	PRODUCT DATA LABEL	1	-
11	5905950	2015 SERIAL TAG-A-5905950	1	-

BendPak
1645 LEMONWOOD DR.
SANTA PAULA, CA 93060

TITLE: XPR-10AS-LP
PRODUCTION LIFT VER F
SIZE DWG. NO. 5260560
REV A
SCALE: 1:35
SHEET 1 OF 2

2382-2585
DRIVE THRU

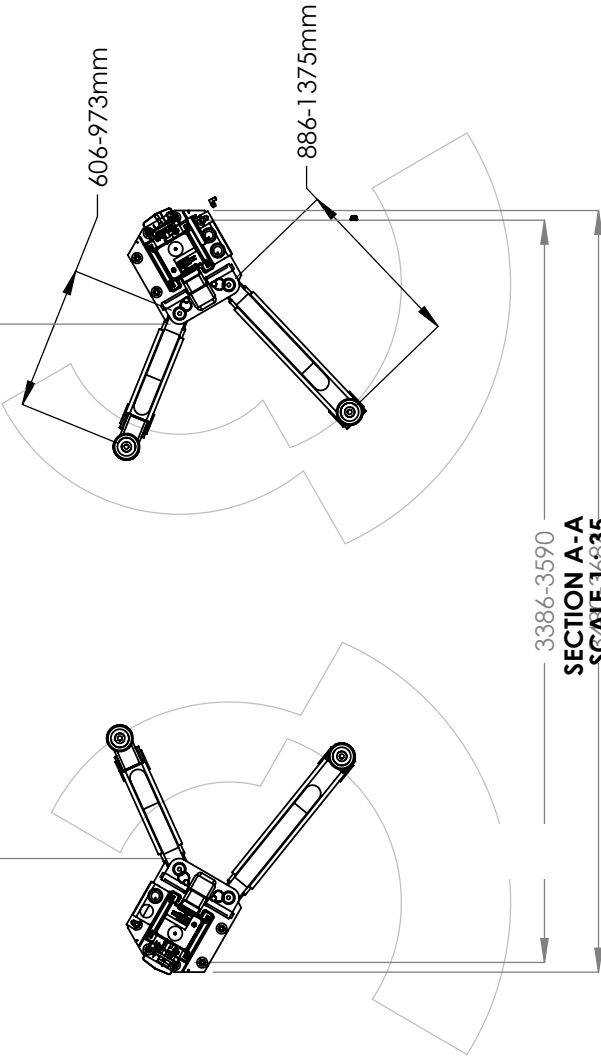

SECTION A-A
SCALE 1:45

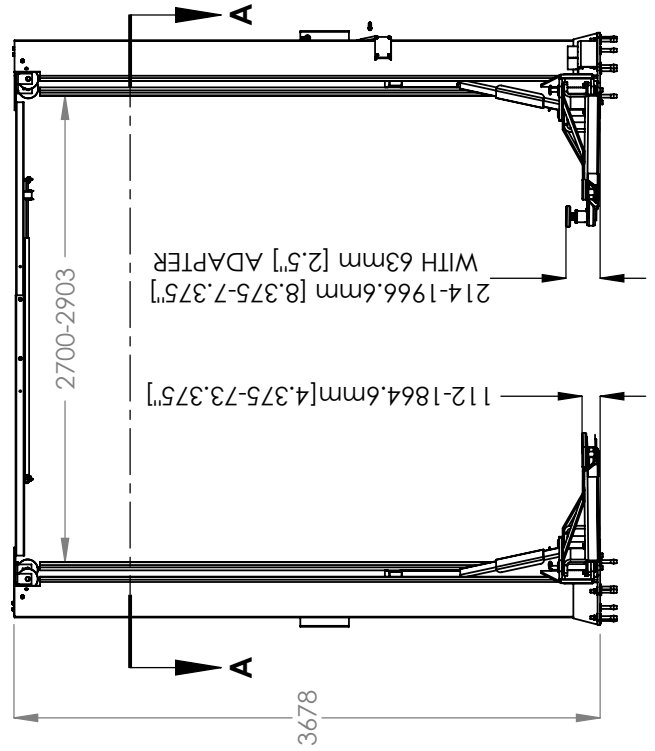

TITLE:		XPR-10AS-LP PRODUCTION LIFT VER F	
SIZE	DWG. NO.	REV	
A	5260560	A	
SCALE: 1:45			SHEET 2 OF 2

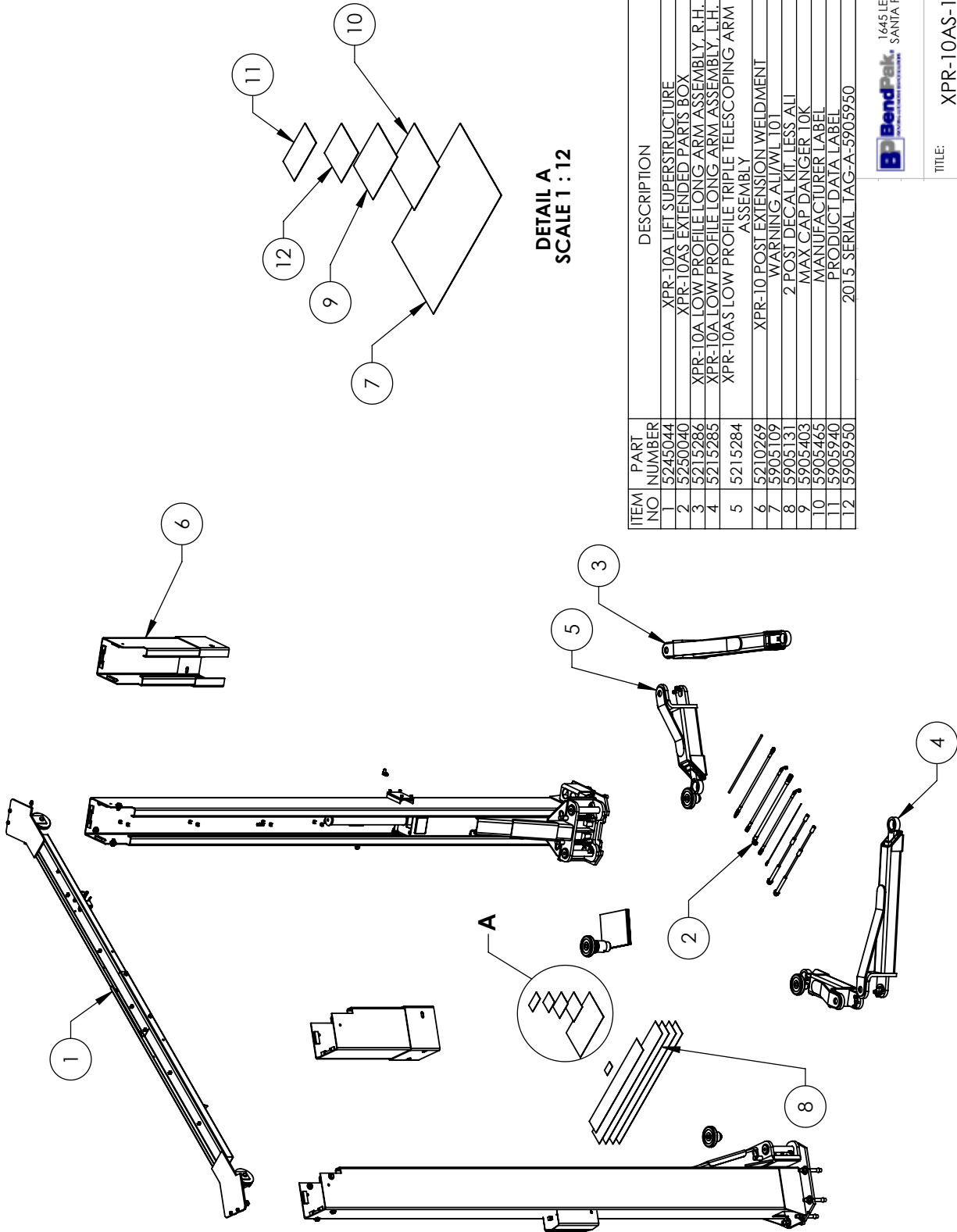

DETAIL A
SCALE 1 : 12

ITEM NO	PART NUMBER	DESCRIPTION	QTY	REV
1	5245044	XPR-10A LIFT SUPERSTRUCTURE	1	D
2	5250040	XPR-10AS EXTENDED PARTS BOX	1	A
3	5215286	XPR-10A LOW PROFILE LONG ARM ASSEMBLY, R.H.	1	C
4	5215285	XPR-10A LOW PROFILE LONG ARM ASSEMBLY, L.H.	1	C
5	5215284	XPR-10AS LOW PROFILE TRIPLE TELESCOPING ARM ASSEMBLY	2	C
6	5210269	XPR-10 POST EXTENSION WELDMENT	2	E
7	5905109	WARNING AL7WL101	1	---
8	5905131	2 POST DECAL KIT, LESS ALL	1	C
9	5905403	MAX CAP DANGER 10K	1	---
10	5905465	MANUFACTURER LABEL	1	---
11	5905940	PRODUCT DATA LABEL	1	---
12	5905950	2015 SERIAL TAG-A-5905950	1	---



TITLE: XPR-10AS-168
PRODUCTION LIFT VER F
REV A

SIZE DWG. NO. 5260561
REV A

SCALE: 1:35 SHEET 1 OF 2

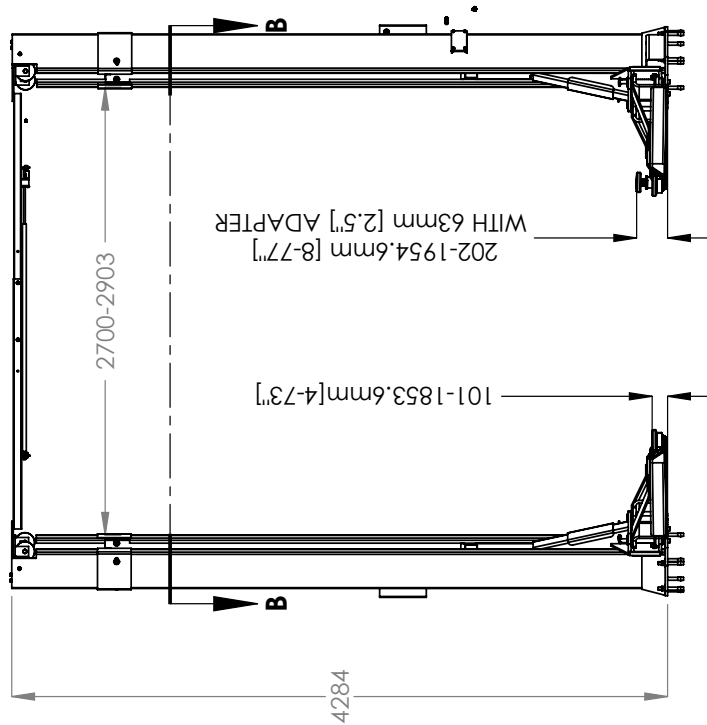
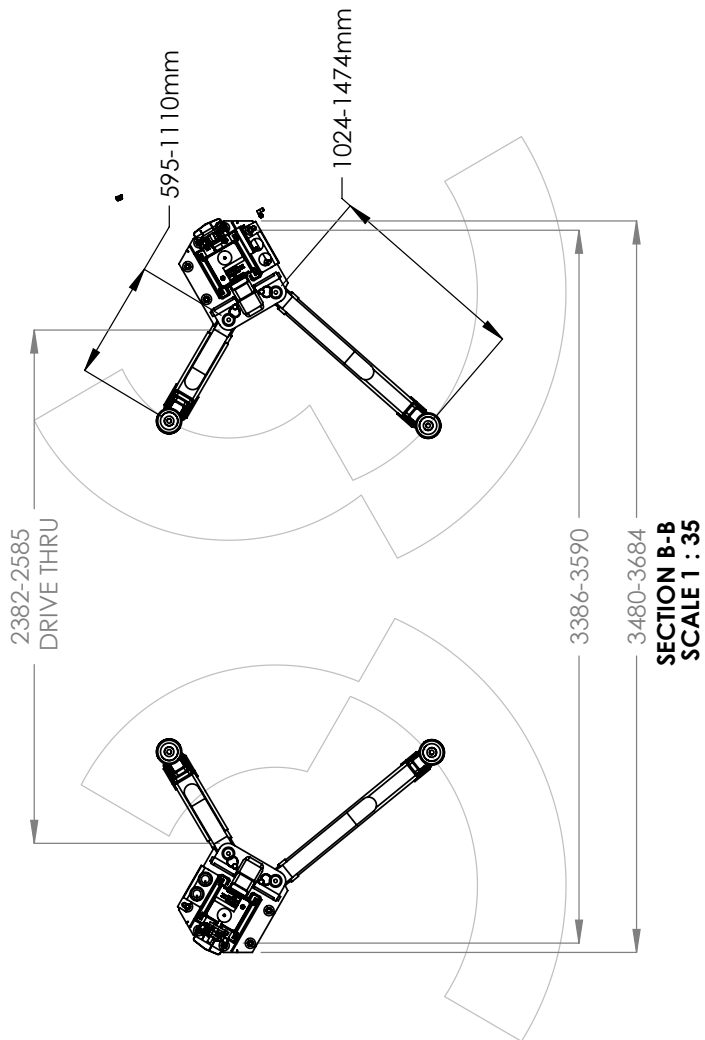

 1645 LEMONWOOD DR. SANTA PAULA, CA 93060	
TITLE:	XPR-10AS-168 PRODUCTION LIFT VER F
SIZE DWG. NO.	A 5260561
REV	A
SCALE: 1:45	
SHEET 2 OF 2	

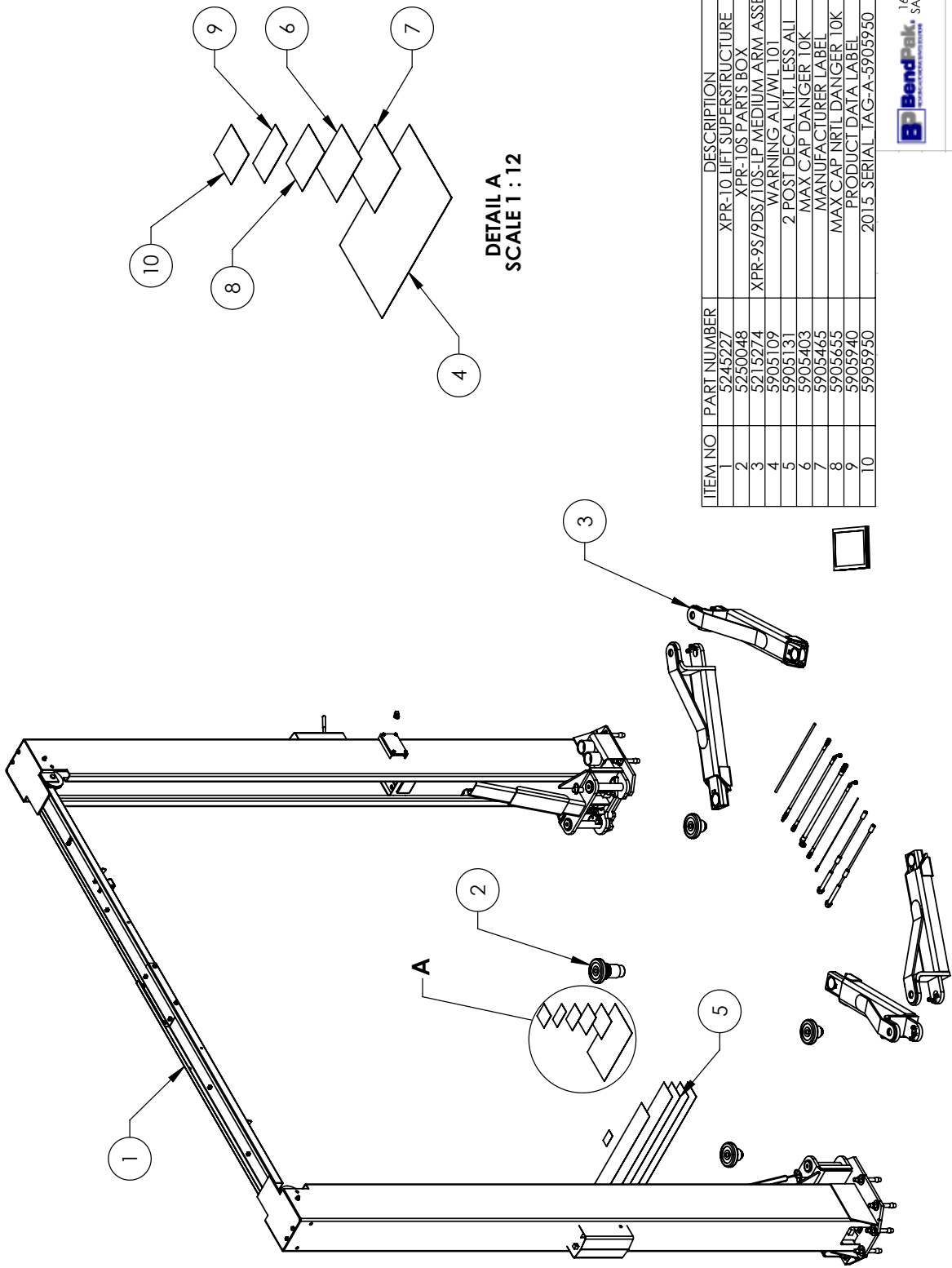

DETAIL A
SCALE 1 : 12

ITEM NO	PART NUMBER	DESCRIPTION	QTY	REV
1	5245227	XPR-10 LIFT SUPERSTRUCTURE	1	R
2	5250048	XPR-10S PARTS BOX	1	A
3	5215274	XPR-9S/9DS/10S-LP MEDIUM ARM ASSEMBLY	4	C
4	5905109	WARNING AL/WL 101	1	-
5	5905131	2 POST DECAL KIT, LESS ALI	1	C
6	5905403	MAX CAP DANGER 10K	1	-
7	5905465	MANUFACTURER LABEL	1	-
8	5905655	MAX CAP NRTL DANGER 10K	1	-
9	5905940	PRODUCT DATA LABEL	1	-
10	5905950	2015 SERIAL TAG-A-5905950	1	-

BendPak 1645 LEMONWOOD DR.
SANTA PAULA, CA 93060

TITLE: XPR-10S-LP
PRODUCTION LIFT VER E
SIZE DWG. NO. 5260566
REV A
SCALE: 1:30 SHEET 1 OF 2

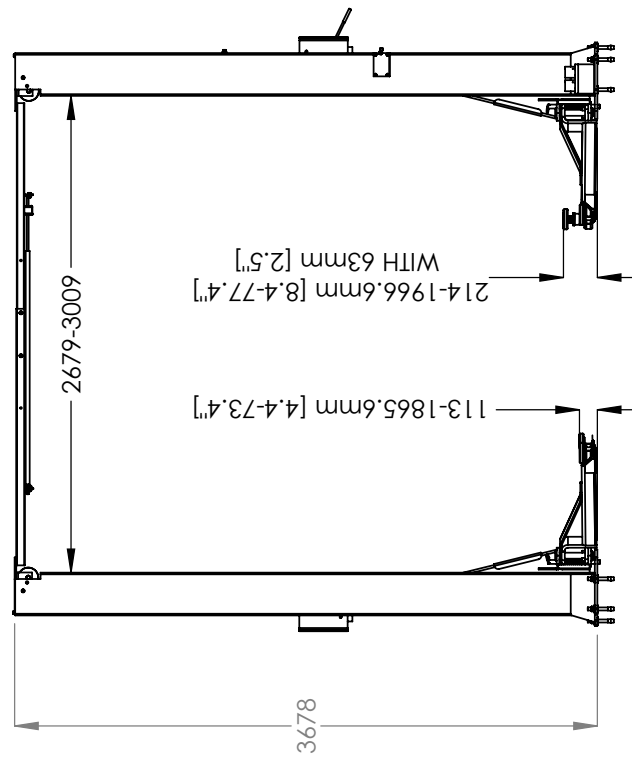
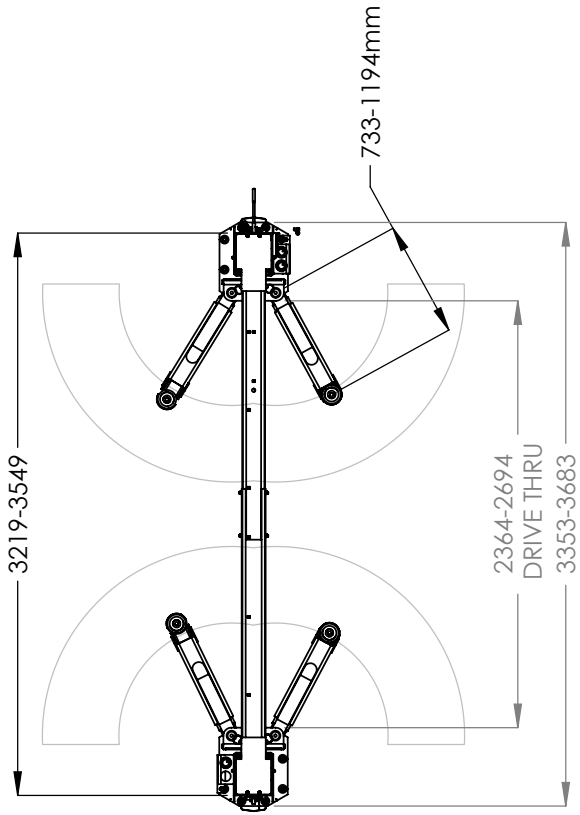

BendPak 1645 LEMONWOOD DR.
SANTA PAULA, CA 93060

TITLE:	XPR-10S-LP PRODUCTION LIFT VER E		
SIZE DWG. NO.	5260566	REV	A
SCALE: 1:45		SHEET 2 OF 2	

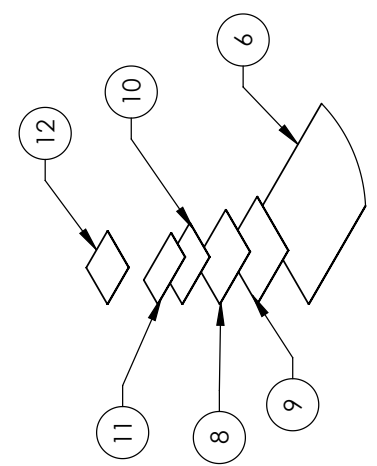
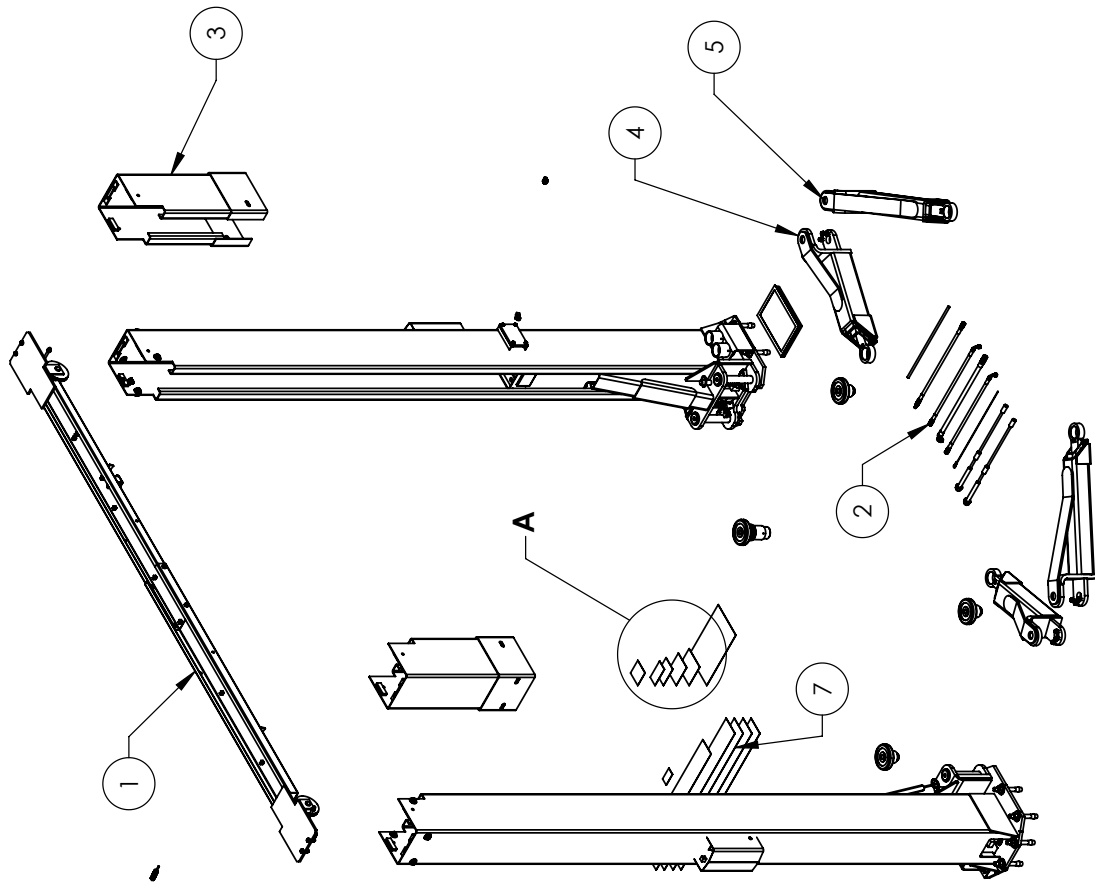

DETAIL A
SCALE 1 : 12

ITEM NO	PART NUMBER	DESCRIPTION	QTY	REV
1	5245227	XPR-10 LIFT SUPERSTRUCTURE	1	R
2	5250049	XPR-10S EXTENDED PARS BOX	1	A
3	5210269	XPR-10 POST EXTENSION WELDMENT	2	E
4	5215287	XPR-9S/9DS/10S LOW PROFILE TELESCOPING ARM ASSEMBLY	2	C
5	5215700	XPR-9S/9DS/10S LOW PROFILE MEDIUM ARM ASSEMBLY	2	C
6	5805109	WARNING ATTACHMENT	1	C
7	5805131	2 POST DECA KIT LESS ALL	1	C
8	5805403	MANUFACTURER LABEL	1	---
9	5805445	MANUFACTURER LABEL	1	---
10	5805642	MANUFACTURER LABEL	1	---
11	5805640	PRODUCT DANGER LABEL	1	---
12	5805950	2015 SERIAL TAG-A-5805950	1	---

BendPak 1645 LEMONWOOD DR.
SANTA PAULA, CA 93060

TITLE: XPR-10S-168
PRODUCTION LIFT VER E

SIZE DWG. NO. A 5260574 REV A

SCALE: 1:35 SHEET 1 OF 2

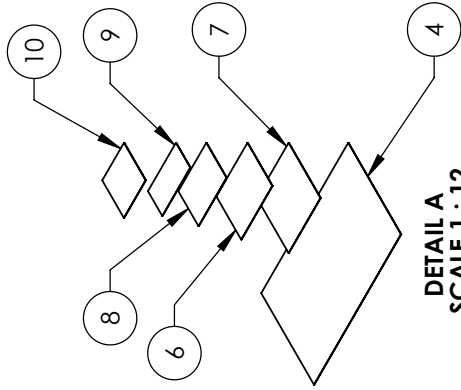
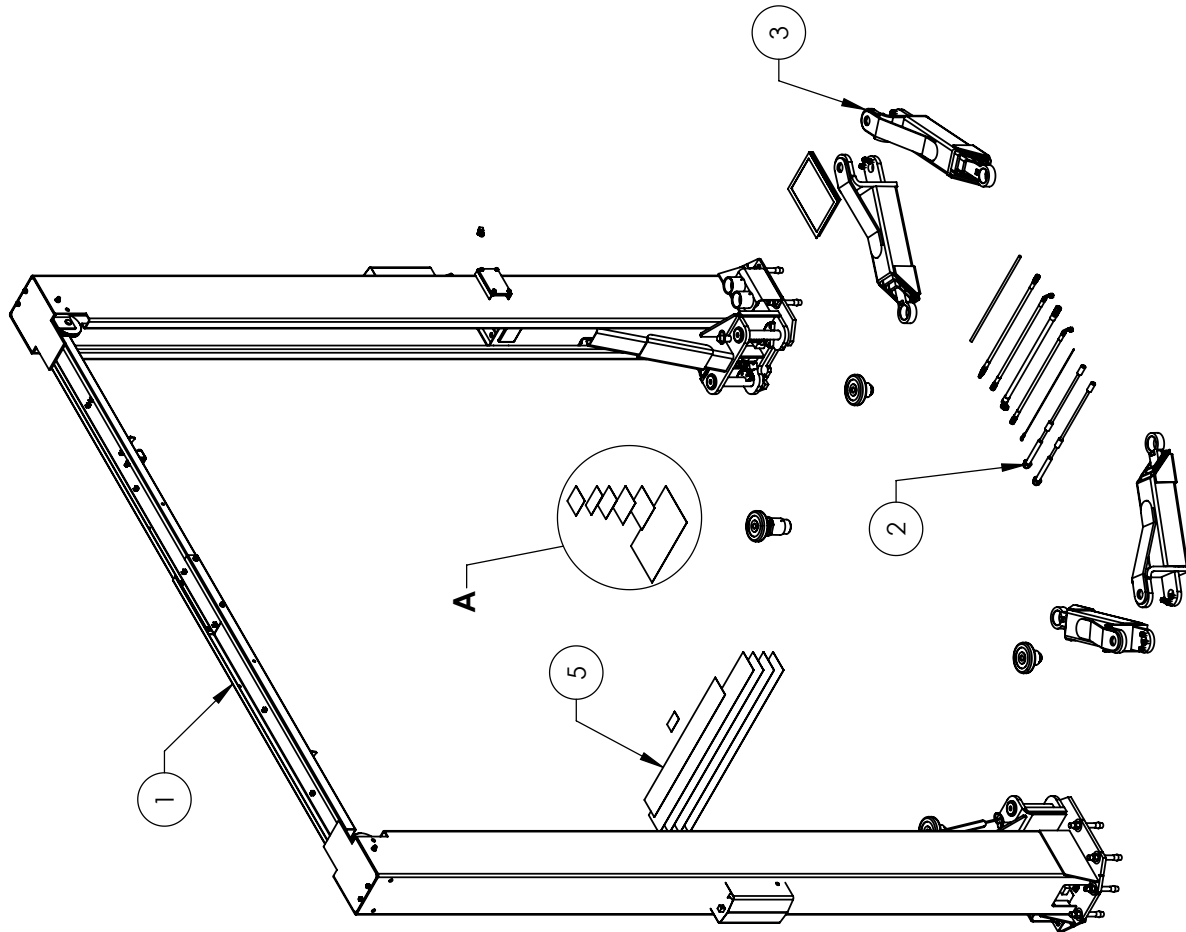

DETAIL A
SCALE 1:12

ITEM NO	PART NUMBER	DESCRIPTION	QTY	REV
1	5245227	XPR-10 LIFT SUPERSTRUCTURE	1	R
2	5250048	XPR-10TS PARTS BOX	1	A
3	5215287	XPR-9S79DS/10S LOW PROFILE TRIPLE TELESCOPING ARM ASSEMBLY	4	C
4	5905109	WARNING ARM KIT	1	---
5	5905197	POST DECAL KIT	1	---
6	5905181	2 POST DECAL KIT LESS ALI	2	C
7	5905403	MAX CAP DANGER LOK	1	---
8	5905465	MANUFACTURER LABEL	1	---
9	5905655	MAX CAP NR/DANGER TOK	1	---
10	5905940	PRODUCT DATA LABEL	1	---
10	5905950	2015 SERIAL TAG-A-5905950	1	---



TITLE: XPR-10TS PRODUCTION
LIFT VER E

SIZE DWG. NO. A 5260572 REV A

SCALE: 1:30 SHEET 1 OF 2

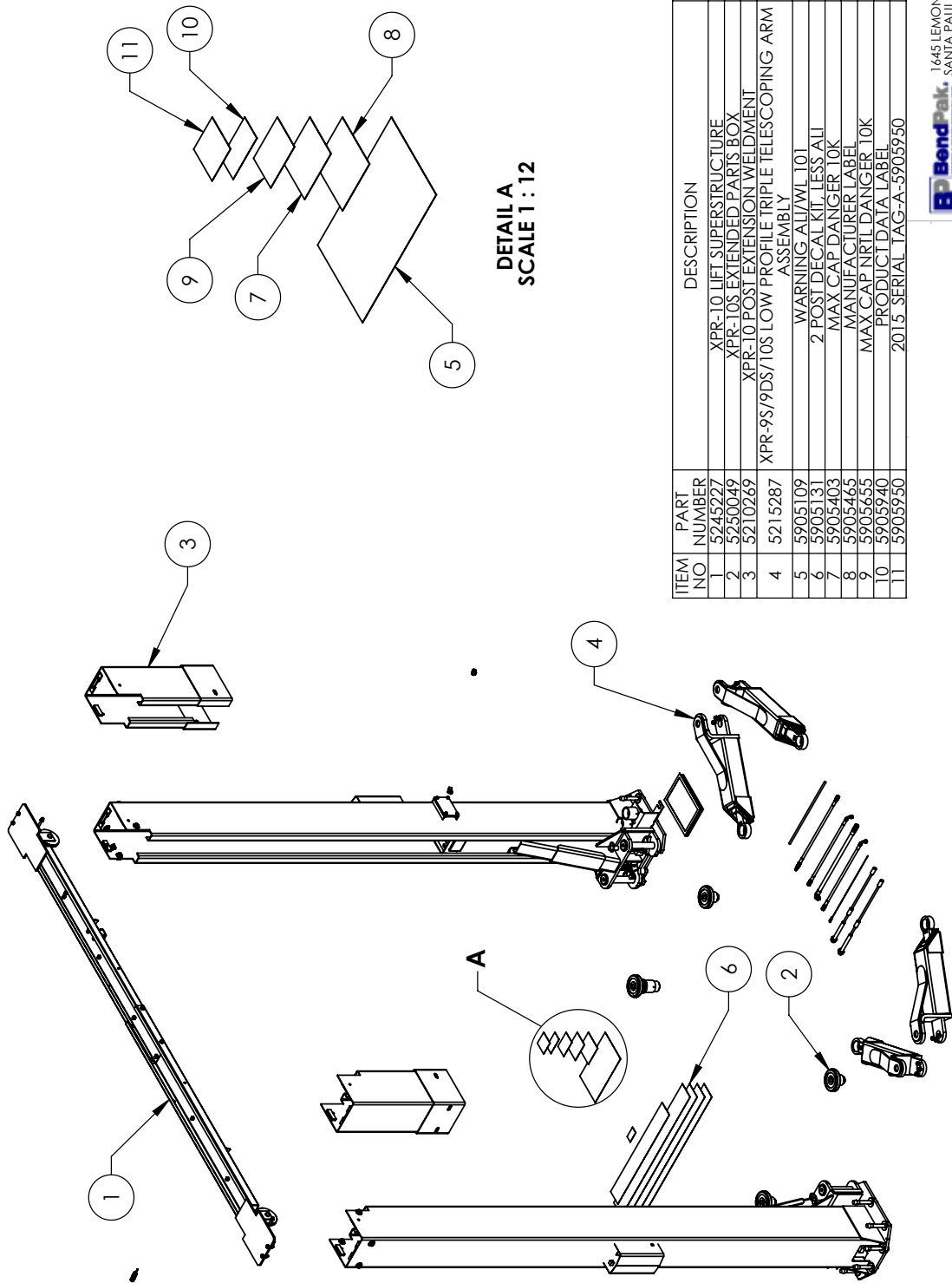

DETAIL A
SCALE 1:12

ITEM NO	PART NUMBER	DESCRIPTION	QTY	REV
1	5245227	XPR-10 LIFT SUPERSTRUCTURE	1	R
2	5250049	XPR-10S EXTENDED PARTS BOX	1	A
3	5210289	XPR-10 POST EXTENSION WELDMENT	2	E
4	5215287	XPR-9S/9DS/10S LOW PROFILE TRIPLE TELESCOPING ARM ASSEMBLY	4	C
5	5905109	WARNING ALI/ML 101	1	---
6	5905131	2 POST DECAL KIT LESS ALL	1	C
7	5905403	MAX CAP DANGER 10K	1	---
8	5905465	MANUFACTURER LABEL	1	---
9	5905655	MAX CAP NR1L DANGER 10K	1	---
10	5905940	PRODUCT DATA LABEL	1	---
11	5905950	2015_SERIAL TAG-A-5905950	1	---

BendPak
1645 LEMONWOOD DR.
SANTA PAULA, CA 93060

TITLE: XPR-10TS-168
PRODUCTION LIFT VER E
REV A
SIZE DWG. NO. 5260573
SCALE: 1:35 SHEET 1 OF 2



Certificate No: CE-GB-20120209-01-08-5C

Date of Issue: 2016.05.13

Date of Expiry: 2020.10.08



No. 0638

EC Type-Examination Certificate

For the requirements of the Machinery Directive 2006/42/EC

For Annex IV machinery

NAME AND ADDRESS OF THE MANUFACTURER: Bendpak Inc.
1645 E. Lemonwood Drive,
Santa Paula, CA,
United States of America

PRODUCT DESCRIPTION/ TYPE AND MODEL: Range of 10,000lb (4536kg) 2 post vehicle servicing lifts. Top bar

XPR-10S	Symmetric	145 H x 132/145W x 69Lift in + Extended
XPR-10S-LP	Symmetric	145 H x 132/145W x 69Lift in
XPR-10S-168	Symmetric	168 H x 132/145W x 69Lift in
XPR-10S-168-LP	Symmetric	168 H x 132/145W x 69Lift in
XPR-10TS	Symmetric	145 H x 132/145W x 69Lift in
XPR-10TS-168	Symmetric	168 H x 132/145W x 69Lift in
XPR-10AS	Asymmetric	145 H x 132/145W x 69Lift in + Extended
XPR-10AS-LP	Asymmetric	145 H x 132/145W x 69Lift in
XPR-10AS-168	Asymmetric	168 H x 132/145W x 69Lift in
XPR-10AS-168-LP	Asymmetric	168 H x 132/145W x 69Lift in

APPLICABLE STANDARDS: EN1493:2010 Vehicle Lifts
EN 60204-1:2006+A1:2009 Safety of machinery - Electrical equipment of machines - Part1:General requirements

TECHNICAL FILE REF. NO. TF-GB-20120209-01-08-5C

A COPY IS AVAILABLE FROM: CCQS UK Ltd., Level 7, Westgate House, Westgate Road,
London W5 1YY UK

The technical file, accompanying documentation and the equipment which they describe have been found to be in conformity with the requirements of the Machinery Directive 2006/42/EC.

The responsible person defined above has responsibility for ensuring that all future serial manufacture of the machinery conforms to the sample submitted for EC type-examination referenced above.

Any changes to the design of the machinery certified here must be advised to CCQS UK Ltd. for re-assessment.

A CE marking should not be fixed to the equipment until the requirements of all relevant directives have been met.

Approved by: Owen Bian – UK Office Manager

Date 13.05.2016

CCQS UK Ltd.,
Level 7, Westgate House,
Westgate Road,
London W5 1YY UK
Tel: +44 (0) 20 8991 3488
Email info@ccqs.co.uk

Notified Body
No. 1105
Appointed by
UK Government

If in any doubt about the integrity of this certificate,
please verify it on our website at
<http://www.ccqs.co.uk>

Declaration of Conformity

The equipment which accompanies this declaration is in conformity with EU Directive:
2006/42/EC Machinery Directive

Manufacturer

BendPak Inc.
1645 Lemonwood Dr
Santa Paula Ca, 93060
USA

A copy of the Technical file for this equipment is available from:
CCQS UK Ltd., Level 7, Westgate House, Westgate Rd., London W5 1YY UK

Description of Equipment
Two-Column Vehicle Service Lift

XPR-10S	10K Cap. / Clearfloor / Two-Post Lift	Serial Numbers 5175395-00000 to 99999-99999-99999
XPR-10S-LP	10K Cap. / Clearfloor / Two-Post Lift	Serial Numbers 5175396-00000 to 99999-99999-99999
XPR-10S-168	10K Cap. / Clearfloor / Two-Post Lift	Serial Numbers 5175399-00000 to 99999-99999-99999
XPR-10TS	10K Cap. / Clearfloor / Two-Post Lift	Serial Numbers 5175413-00000 to 99999-99999-99999
XPR-10TS-168	10K Cap. / Clearfloor / Two-Post Lift	Serial Numbers 5175414-00000 to 99999-99999-99999
XPR-10AS	10K Cap. / Asymmetric Clearfloor / Two-Post Lift	Serial Numbers 5175397-00000 to 99999-99999-99999
XPR-10AS-LP	10K Cap. / Asymmetric Clearfloor / Two-Post Lift	Serial Numbers 5175398-00000 to 99999-99999-99999
XPR-10AS-168	10K Cap. / Asymmetric Clearfloor / Two-Post Lift	Serial Numbers 5175401-00000 to 99999-99999-99999
XPR-10AS-168-LP	10K Cap. / Asymmetric Clearfloor / Two-Post Lift	Serial Numbers 5175402-00000 to 99999-99999-99999

A sample of this machinery has been presented to Notified Body number 1105.
CCQS UK Ltd., Level 7, Westgate House, Westgate Rd., London W5 1YY UK
Who have issued an EC type-examination certificate number CE-GB-20150427-01-5A dated 2015.12.10.
The equipment in respect of which this declaration is made conforms to the example to which that certificate relates, and that certificate remains valid.

This declaration of conformity is issued under the sole responsibility of the manufacturer.

The following harmonised standards have been used:
EN1493:2010 Vehicle Lifts

Authorised signatory of manufacturer



Signature:

Name of signatory:

Jeffrey S. Kritzer

Position in company: Senior Vice President of Marketing and Sales

Place signed: Santa Paula, CA, USA

Date signed: February 9, 2016



1645 Lemonwood Dr. ● Santa Paula, CA. 93060, USA
Toll Free: 1(800) 253-2363

FOR TECHNICAL SUPPORT
1-(800) 253-2363 Ext. 196
TO ORDER PARTS
1-(800) 253-2363 Ext. 191