

# ⚠ WARNING

## EUROPEAN USERS

400V 50Hz SUPPLY DETAILS ARE INCLUDED WITH ELECTRICAL CONTROL BOX. DISREGARD SUPPLY WIRING DETAILS IN THIS MANUAL

## IMPORTANT SAFETY INSTRUCTIONS SAVE THESE INSTRUCTIONS

PLEASE READ THE ENTIRE CONTENTS OF THIS MANUAL PRIOR TO INSTALLATION AND OPERATION. BY PROCEEDING WITH LIFT INSTALLATION AND OPERATION YOU AGREE THAT YOU FULLY UNDERSTAND AND COMPREHEND THE FULL CONTENTS OF THIS MANUAL. FORWARD THIS MANUAL TO ALL OPERATORS. FAILURE TO OPERATE THIS EQUIPMENT AS DIRECTED MAY CAUSE INJURY OR DEATH.

Manual Revision H7 - January 2021  
Manual Part Number 5900160

# INSTALLATION AND OPERATION MANUAL

## SUPER-DUTY FOUR-POST LIFTS

Models:  
HDS-18E  
HDS-27 / HDS-27X  
HDS-40 / HDS-40X

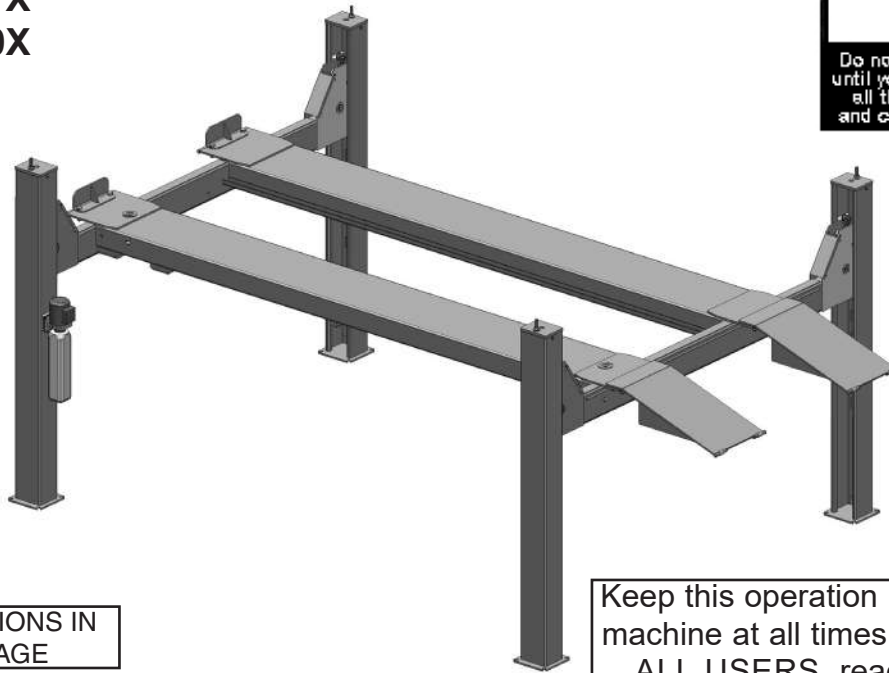

ORIGINAL INSTRUCTIONS IN ENGLISH LANGUAGE

Keep this operation manual near the machine at all times. Make sure that **ALL USERS** read this manual.

### RECEIVING

The shipment should be thoroughly inspected as soon as it is received. The signed Bill of Lading is acknowledgement by the shipping carrier as receipt of this product as listed in your invoice as being in a good condition of shipment. If any of these goods listed on this Bill of Lading are missing or damaged, do not accept goods until the shipping carrier makes a notation on the freight bill of the missing or damaged goods. Do this for your own protection.

### BE SAFE

Your new lift was designed and built with safety in mind. However, your overall safety can be increased with proper training and thoughtful operation on the part of the operator. DO NOT operate or repair this equipment without reading this manual and the important safety instructions shown inside. Keep this operation manual near the lift at all times. Make sure that **ALL USERS** read and understand this manual.

Copyright ©2021 by BendPak Inc. All rights reserved.



1645 Lemonwood Dr.  
Santa Paula, CA. 93060, USA  
Toll Free (800) 933-9970  
Tel: (805) 253-2363  
www.bendpak.com



## IMPORTANT NOTICE

Do not attempt to install this lift if you have never been trained on basic automotive lift installation procedures.

Never attempt to lift components without proper lifting tools such as forklift or cranes. Stay clear of any moving parts that can fall and cause injury. These instructions must be followed to insure proper installation and operation of your lift. Failure to comply with these instructions can result in serious bodily harm and void product warranty. Manufacturer will assume no liability for loss or damage of any kind, expressed or implied resulting from improper installation or use of this product.

PLEASE READ THE ENTIRE CONTENTS OF THIS MANUAL PRIOR TO INSTALLATION AND OPERATION. BY PROCEEDING YOU AGREE THAT YOU FULLY UNDERSTAND AND COMPREHEND THE FULL CONTENTS OF THIS MANUAL.

## DEFINITIONS OF HAZARD LEVELS

Identify the hazard levels used in this manual with the following definitions and signal words:



### DANGER

Watch for this symbol: It Means: Immediate hazards which will result in severe personal injury or death.



### WARNING

Watch for this symbol: It Means: Hazards or unsafe practices which could result in severe personal injury or death.



### CAUTION

Watch for this symbol: It Means: Hazards or unsafe practices which may result in minor personal injury or product or property damage.

## OWNER'S RESPONSIBILITY

To maintain the lift and user safety, the responsibility of the owner is to read and follow these instructions:

- ◆ Follow all installation and operation instructions.
- ◆ Make sure installation conforms to all applicable Local, State, and Federal Codes, Rules, and Regulations; such as State and Federal OSHA Regulations and Electrical Codes.
- ◆ Carefully check the lift for correct initial function.
- ◆ Read and follow the safety instructions. Keep them readily available for machine operators.
- ◆ Make certain all operators are properly trained, know how to safely and correctly operate the unit, and are properly supervised.
- ◆ Allow unit operation only with all parts in place and operating safely.
- ◆ Carefully inspect the unit on a regular basis and perform all maintenance as required.
- ◆ Service and maintain the unit only with authorized or approved replacement parts.
- ◆ Keep all instructions permanently with the unit and all decal's on the unit clean and visible.

## BEFORE YOU BEGIN

### Receiving:

The shipment should be thoroughly inspected as soon as it is received. The signed bill of lading is acknowledgement by the carrier of receipt in good condition of shipment covered by your invoice. If any of the goods called for on this bill of lading are shorted or damaged, do not accept them until the carrier makes a notation on the freight bill of the shorted or damaged goods. Do this for your own protection.

**NOTIFY THE CARRIER AT ONCE** if any hidden loss or damage is discovered after receipt and request the carrier to make an inspection. If the carrier will not do so, prepare a signed statement to the effect that you have notified the carrier (on a specific date) and that the carrier has failed to comply with your request.

**IT IS DIFFICULT TO COLLECT FOR LOSS OR DAMAGE AFTER YOU HAVE GIVEN THE CARRIER A CLEAR RECEIPT.** File your claim with the carrier promptly. Support your claim with copies of the bill of lading, freight bill, invoice, and photographs, if available. Our willingness to assist in helping you process your claim does not make Ranger Products responsible for collection of claims or replacement of lost or damaged materials.

# TABLE OF CONTENTS

Contents	Page No.
Warranty . . . . .	2
Definitions of Hazard Levels . . . . .	3
Owner's Responsibility . . . . .	3
Before You Begin . . . . .	3
Protective Equipment . . . . .	5
Introduction / Safety / Warning Instructions . . . . .	6
Step 1 / Selecting Site . . . . .	7
Step 2 / Floor Requirements . . . . .	7
Concrete Specifications . . . . .	7
Assembly View / Description of Parts . . . . .	8
Floor Plan / Specifications . . . . .	9-10
Clearances / Shim Estimates . . . . .	11
Power Unit Location . . . . .	12
Step 3 / Column and Cross Tube Installation . . . . .	13-14
Step 4 / Raising the Cross Tubes . . . . .	14
Step 5 / Powerside Runway Installation . . . . .	15
Step 6 / Offside Runway Installation . . . . .	15
Step 7 / Cable / Sheave Installation . . . . .	15-18
Step 8 / Power Unit Installation . . . . .	19
Step 9 / Routing Hydraulic Hoses . . . . .	19-20
Step 10 / Routing Air Lines . . . . .	21-22
Wiring Diagram . . . . .	24
Step 11 / Power Unit Hook Up . . . . .	25
Step 12 / Installing Slack Safety Springs . . . . .	25
Step 13 / Lift Start Up/Final Adjustments . . . . .	25-26
Step 14 / Anchoring The Columns . . . . .	26-27
Step 15 / Final Assembly . . . . .	27
Step 16 / Leveling / Synchronizing . . . . .	27-28
Step 17 / Bleeding . . . . .	28
Optional Equipment Installation . . . . .	29-30
Step 19 / Operation Instructions . . . . .	31
Step 20 / Lift Operation Safety . . . . .	31-33
Wire Rope Inspection and Maintenance . . . . .	34
Safe Lift Operation . . . . .	37-38
Troubleshooting . . . . .	37-40
Lubrication Points . . . . .	41
Labels . . . . .	42-44
Parts Drawings . . . . .	45-52
CE Certificate . . . . .	53
Certificate of Compliance . . . . .	55

**INSTALLER / OPERATOR  
PLEASE READ AND FULLY  
UNDERSTAND. BY PROCEEDING  
YOU AGREE TO THE FOLLOWING:**

◆ I have visually inspected the site where the lift is to be installed and verified the concrete to be in good condition and free of cracks or other defects. I understand that installing a lift on cracked or defective concrete could cause lift failure resulting in personal injury or death.

◆ I understand that a level floor is required for proper installation and level lifting.

◆ I understand that I am responsible if my floor is of questionable slope and that I will be responsible for all charges related to pouring a new level concrete slab if required and any charges.

◆ I understand that BendPak lifts are supplied with concrete fasteners meeting the criteria of the American National Standard “Automotive Lifts - Safety Requirements for Construction, Testing, and Validation” ANSI/ ALI ALCTV-2011, and that I will be responsible for all charges related to any special regional structural and/ or seismic anchoring requirements specified by any other agencies and/ or codes such as the Uniform Building Code (UBC) and/ or International Building Code (IBC).

◆ I will assume full responsibility for the concrete floor and condition thereof, now or later, where the above equipment model(s) are to be installed. Failure to follow danger, warning, and caution instructions may lead to serious personal injury or death to operator or bystander or damage to property.

◆ I understand that Bendpak lifts are designed to be installed in indoor locations only. Failure to follow installation instructions may lead to serious personal injury or death to operator or bystander or damage to property or lift



Failure to follow danger, warning, and caution instructions may lead to serious personal injury or death to operator or bystander or damage to property.



Please read entire manual prior to installation. Do not operate this machine until you read and understand all the dangers, warnings and cautions in this manual. For additional copies or further information, contact:

BendPak Inc. / Ranger Products  
1645 Lemonwood Dr.,  
Santa Paula, CA. 93060  
1-805-933-9970  
www.bendpak.com

**INSTALLER / OPERATOR  
PROTECTIVE EQUIPMENT**

Personal protective equipment helps makes installation and operation safer, however, does not take the place of safe operating practices. Always wear durable work clothing during any installation and/ or service activity. Shop aprons or shop coats may also be worn, however loose fitting clothing should be avoided. Tight fitting leather gloves are recommended to protect technician hands when handling parts. Sturdy leather work shoes with steel toes and oil resistant soles should be used by all service personnel to help prevent injury during typical installation and operation activities.

Eye protection is essential during installation and operation activities. Safety glasses with side shields, goggles, or face shields are acceptable. Back belts provide support during lifting activities and are also helpful in providing worker protection. Consideration should also be given to the use of hearing protection if service activity is performed in an enclosed area, or if noise levels are high.



**THIS SYMBOL POINTS OUT IMPORTANT SAFETY INSTRUCTIONS WHICH IF NOT FOLLOWED  
COULD ENDANGER THE PERSONAL SAFETY AND / OR PROPERTY OF YOURSELF AND OTHERS  
AND CAN CAUSE PERSONAL INJURY OR DEATH. READ AND FOLLOW ALL INSTRUCTIONS IN THIS  
MANUAL BEFORE ATTEMPTING TO OPERATE THIS MACHINE.**

## INTRODUCTION

1. Carefully remove the crating and packing materials. **CAUTION!** Be careful when cutting steel banding material as items may become loose and fall causing personal harm or injury.

2. Check the voltage, phase, and proper amperage requirements for the motor shown on the motor plate. Electrical work should be performed only by a certified electrician.

### IMPORTANT SAFETY INSTRUCTIONS

Read these safety instructions entirely. Do not attempt to install this lift if you have never been trained on basic automotive lift installation procedures. Never attempt to lift components without proper lifting tools such as forklift or cranes. Stay clear of any moving parts that may fall and cause injury. When using your garage equipment, basic safety precautions should always be followed, including the following:

1. Read and understand all instructions and all safety warnings before operating lift.
2. Care must be taken as burns can occur from touching hot parts.
3. Do not operate equipment with a damaged cord or if the equipment has been dropped or damaged until it has been examined by a qualified service person.
4. Do not let a cord hang over the edge of the table, bench, or counter or come in contact with hot manifolds or moving fan blades.
5. If an extension cord is necessary, a cord with a current rating equal to or more than that of the equipment should be used. Cords rated for less current than the equipment may overheat. Care should be taken to arrange the cord so that it will not be tripped over or pulled.
6. Always unplug equipment from electrical outlet when not in use. Never use the cord to pull the plug from the outlet. Grasp plug and pull to disconnect.
7. Let equipment cool completely before putting away. Loop cord loosely around equipment when storing.
8. To reduce the risk of fire, do not operate equipment in the vicinity of open containers of flammable liquids (gasoline).
9. Adequate ventilation should be provided when working on operating internal combustion engines.
10. Keep hair, loose clothing, fingers, and all parts of body away from moving parts. Keep feet clear of lift when lowering. Avoid pinch points.
11. **DANGER!** To reduce the risk of electric shock, do not use on wet surfaces or expose to rain. The power unit used on this lift contains high voltage. Disconnect power at the receptacle or at the circuit breaker switch before performing any electrical repairs. Secure plug so that it cannot be accidentally plugged in during service, or mark the circuit breaker so that it cannot be accidentally switched on during service.
12. Use only as described in this manual. Use only manufacturer's recommended attachments.



13. **ALWAYS WEAR SAFETY GLASSES.** Everyday eye-glasses only have impact resistant lenses, they are not safety glasses.
14. Consider work environment. Keep work area clean. Cluttered work areas invite injuries. Keep areas well lit.
15. Guard against electric shock. This lift must be grounded while in use to protect operator from electric shock. Never connect the green power cord wire to a live terminal. This is for ground only.
16. Only trained operators should operate this lift. All non-trained personnel should be kept away from the work area. Never let non-trained personnel come in contact with, or operate lift.
17. **DO NOT** override self-closing lift controls.
18. Clear area if vehicle is in danger of falling.
19. **ALWAYS** make sure the safeties are engaged before attempting to work on or near a vehicle.
20. **WARNING! RISK OF EXPLOSION.** This equipment has internal arcing or sparking parts which should not be exposed to flammable vapors. This machine should not be located in a recessed area or below floor level.
21. **MAINTAIN WITH CARE.** Keep lift clean for better and safer performance. Follow manual for proper lubrication and maintenance instructions. Keep control handles and/or buttons dry, clean and free from grease and oil.
22. Check for damaged parts. Check for alignment of moving parts, breakage of parts or any condition that may affect operation of lift. Do not use lift if any component is broken or damaged.
23. **NEVER** remove safety related components from the lift. Do not use lift if safety related components are missing or damaged.
24. **STAY ALERT.** Use common sense and watch what you are doing. Remember, **SAFETY FIRST.**



**SAVE THESE INSTRUCTIONS**

## TOOLS REQUIRED

- |   |   |
|---|---|
| <ul style="list-style-type: none"> <li>◆ Rotary Hammer Drill Or Similar</li> <li>◆ 3/4" Masonry Bit</li> <li>◆ Hammer</li> <li>◆ 4 Foot Level</li> <li>◆ Open-End Wrench Set: SAE/ Metric</li> <li>◆ Socket And Ratchet Set: SAE/ Metric</li> <li>◆ Hex-Key / Allen Wrench Set</li> </ul> | <ul style="list-style-type: none"> <li>◆ Large Crescent Wrench</li> <li>◆ Large Wrench</li> <li>◆ Crow Bar</li> <li>◆ Chalk Line</li> <li>◆ Medium Flat Screwdriver</li> <li>◆ Tape Measure: 25 Foot Minimum</li> <li>◆ Needle Nose Pliers</li> </ul> |
|---|---|

**NOTE:**

**An air supply (30 PSI Min. / 3 CFM Min.) will be required for the safety-lock mechanisms. See Step 10.**

### IMPORTANT NOTICE !

These instructions must be followed to insure proper installation and operation of your lift. Failure to comply with these instructions can result in serious bodily harm and void product warranty. Manufacturer will assume no liability for loss or damage of any kind, expressed or implied resulting from improper installation or use of this product.

### PLEASE READ ENTIRE MANUAL PRIOR TO INSTALLATION !

#### STEP 1

(Selecting Site)



Before installing your new lift, check the following.

1. **LIFT LOCATION:** Always use architects plans when available. Check clearance dimensions against floor plan requirements making sure adequate space is available.
2. **OVERHEAD OBSTRUCTIONS:** The area where the lift will be located should be free of overhead obstructions such as heaters, building supports, electrical lines etc.
3. **DEFECTIVE FLOOR:** Visually inspect the installation site and check for cracked or defective concrete.
4. **OPERATING TEMPERATURE.** Operate lift only between temperatures of 41° -104° F.
5. Lift is designed for **INDOOR INSTALLATION ONLY.** Outdoor use is prohibited. Always follow warnings illustrated on equipment labels.

- ◆ **DO NOT** install or use this lift on any asphalt surface or any surface other than concrete.
- ◆ **DO NOT** install or use this lift on expansion seams or on cracked or defective concrete.
- ◆ **DO NOT** install or use this lift on a second / elevated floor without first consulting building architect.
- ◆ **DO NOT** install this lift outside. It is only approved for indoor installations.
- ◆ Refer to ANSI/ALI ALIS Standard (R2015) *Safety Requirements for Installation and Service* for more information about safely installing your Lift.

#### CONCRETE SPECIFICATIONS

LIFT MODEL	CONCRETE REQUIREMENT
HDS-18E	4.25" Min. Thickness / 3,000 PSI Min.
HDS-27 / HDS-27X	4.25" Min. Thickness / 3,000 PSI Min.
HDS-40 / HDS-40X	6.5" Min. Thickness / 3,000 PSI Min.

#### STEP 2

(Floor Requirements)



This lift must be installed on a solid level concrete floor with no more than 3-degrees of slope. Failure to do so could cause personal injury or death.

A level floor is suggested for proper use and installation and level lifting. If a floor is of questionable slope, consider a survey of the site and/ or the possibility of pouring a new level concrete slab.



#### DANGER !

All models **MUST** be installed on 3,000 PSI concrete only conforming to the minimum requirements shown above. New concrete must be adequately cured by at least 28 days minimum.

#### IMPORTANT NOTE:

BendPak lifts are supplied with installation instructions and concrete fasteners meeting the criteria as prescribed by the American National Standard "Automotive Lifts - Safety Requirements for Construction, Testing, and Validation" ANSI/ ALI ALCTV-2011. Lift buyers are responsible for any special regional structural and/ or seismic anchoring requirements specified by any other agencies and/or codes such as the Uniform Building Code (UBC) and/ or International Building Code (IBC).

**⚠ DANGER**

When removing the lift from shipping angles pay close attention as the posts can slide and can cause injury. Prior to removing the bolts make sure the posts are held securely by a fork lift or some other heavy lifting device.

**Assembly View  
HDS-18 / 27 / 40**

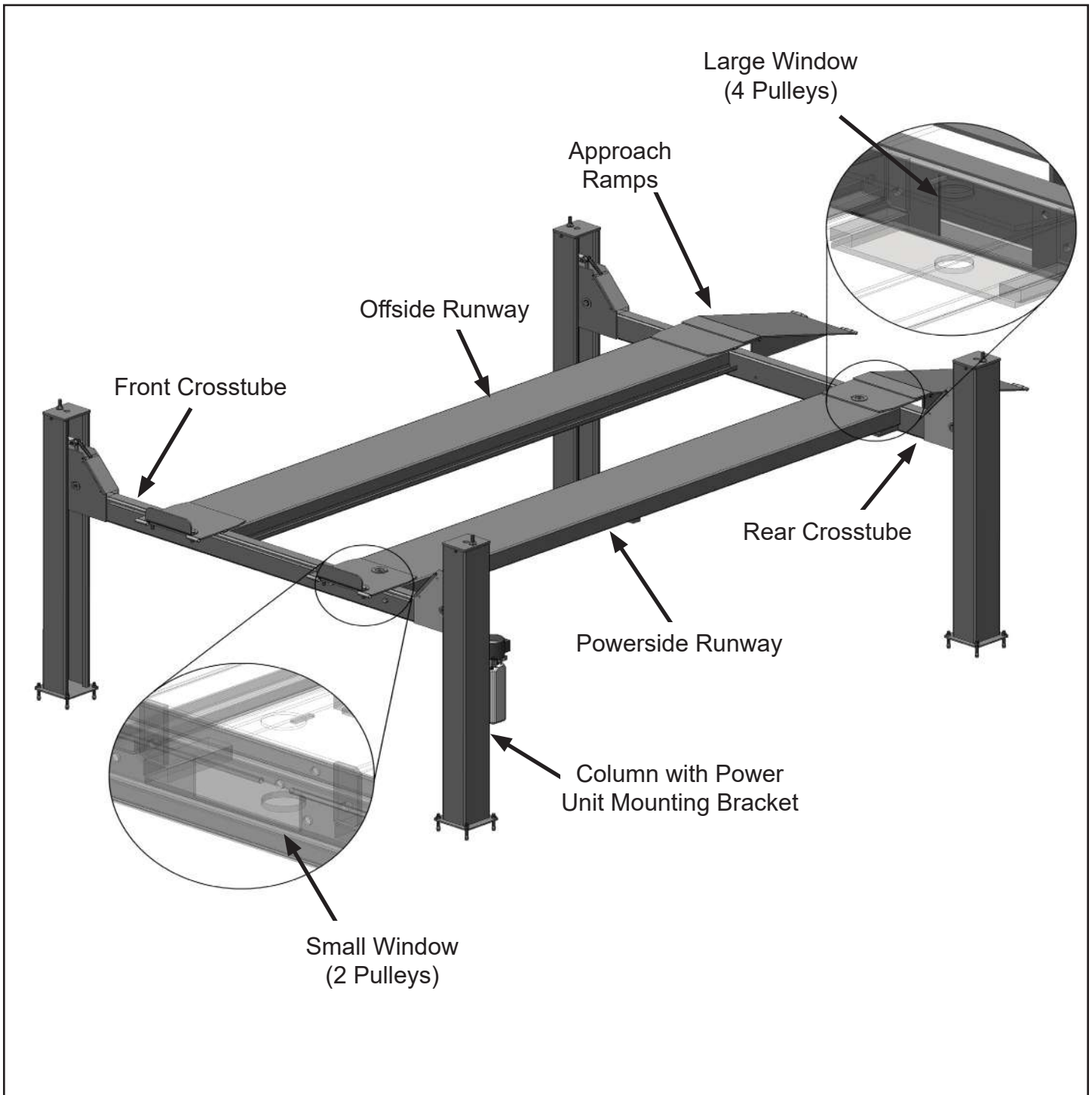



## FLOOR PLAN

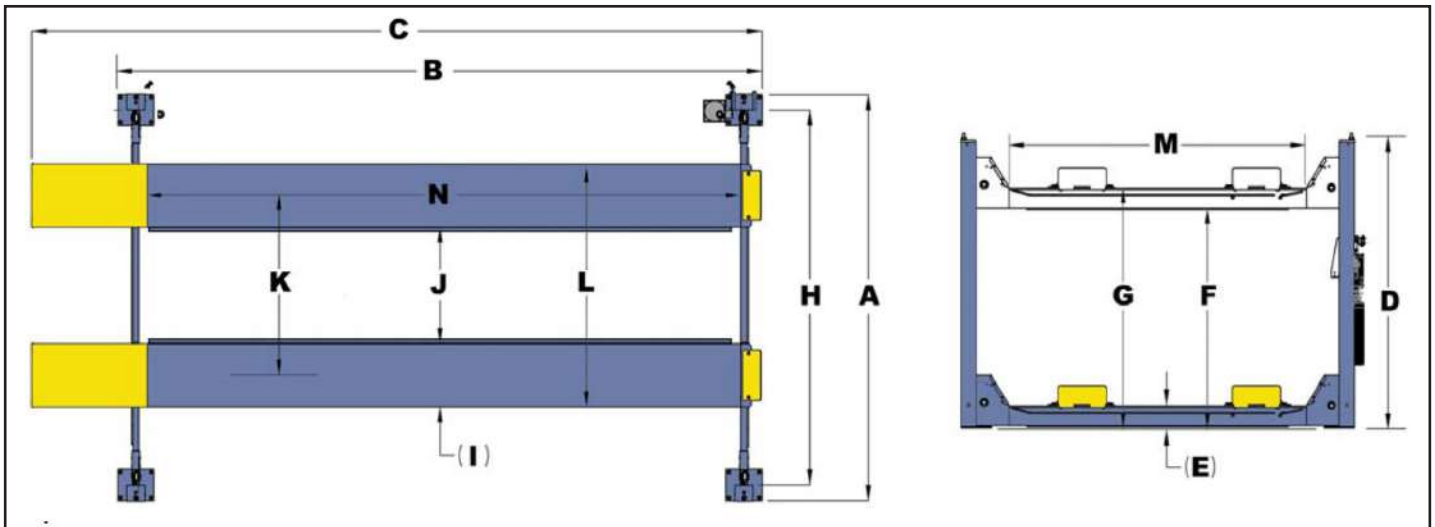

**\*IMPORTANT NOTE\***  
**Check Diagonal Measurements**  
**To Ensure Square Layout - Diagonal Measurements Must Be Equal.**

MODEL	HDS-18E	HDS-27	HDS-27X
Lifting Capacity*	18,000 lbs. / 8165 Kg.	27,000 lbs. / 12,247 Kg.	27,000 lbs. / 12,247 Kg.
*Max Capacity / Front Axle	9,000 lbs. / 4082 Kg.	13,500 lbs. / 6,124 Kg.	13,500 lbs. / 6,124 Kg.
*Max Capacity / Rear Axle	9,000 lbs. / 4082 Kg.	13,500 lbs. / 6,124 Kg.	13,500 lbs. / 6,124 Kg.
A -Overall Width	153-1/2" / 3899 mm	153-1/2" / 3899 mm	153-1/2" / 3899 mm
B -Outside Length	257" / 6528 mm	257" / 6528 mm	317" / 8052 mm
C -Overall Length	309-1/4" / 7856 mm	312-1/2" / 7940 mm	376-3/4" / 9569 mm
D -Height of Columns	91-1/4" / 2318 mm	91-1/4" / 2318 mm	91-1/4" / 2318 mm
E -Min. Runway Height	8-1/2" / 216 mm	9-1/2" / 240 mm	9-1/2" / 240 mm
F -Max. Rise	60" / 1526 mm	60" / 1524 mm	60" / 1524 mm
G -Max. Lifting Height	69-1/2" / 1766 mm	69-1/2" / 1764 mm	69-1/2" / 1764 mm
H -Width Between Columns	133-1/2" / 3391 mm	133-1/2" / 3391 mm	133-1/2" / 3391 mm
I -Runway Width	22" / 559 mm	22" / 559 mm	22" / 559 mm
J -Width Between Runways (*) MIN	40" / 1016 mm	40" / 1016 mm	40" / 1016 mm
J -Width Between Runways (*) MAX	45-1/4" / 1427 mm	45-1/4" / 1149 mm	45-1/4" / 1149 mm
K -Runway Centerline (*) MIN	67" / 1702 mm	67" / 1702 mm	67" / 1702 mm
K -Runway Centerline (*) MAX	72-1/4" / 1835 mm	72-1/4" / 1835 mm	72-1/4" / 1835 mm
L -Outside Edge of Runways (*) MIN	89" / 2261 mm	89" / 2261 mm	89" / 2261 mm
L -Outside Edge of Runways (*) MAX	94-1/4" / 2394 mm	94-1/4" / 2394 mm	94-1/4" / 2394 mm
M -Drive-Thru-Clearance	109" / 2769 mm	109" / 2769 mm	109" / 2769 mm
N -Length of Runways	257" / 6528 mm	256-1/2" / 6520 mm	318-3/4" / 8098 mm
Min. Wheelbase @ Rated Capacity	185" / 4699 mm	185" / 4699 mm	230" / 5842 mm
Min. Wheelbase @ 75% Capacity	160" / 4064 mm	160" / 4064 mm	195" / 4953 mm
Min. Wheelbase @ 50% Capacity	135" / 3429 mm	135" / 3429 mm	165" / 4191 mm
Min. Wheelbase @ 25% Capacity	110" / 2794 mm	110" / 2794 mm	130" / 3302 mm
Locking Positions	13	13	13
Lock Spacing	Every 4" / 100 mm	Every 4" / 100 mm	Every 4" / 100 mm
Lifting Time	75 Seconds	75 Seconds	75 Seconds
Standard Motor (**)	220 VAC / 60 Hz. 1Ph.	220 VAC / 60 Hz. 1Ph.	220 VAC / 60 Hz. 1Ph.
Emission sound pressure at Operator Position < 70 dB(A)			
* This dimension may be limited with the addition of rolling jacks. See Rolling Jack Specifications on Separate page.			
** For CE compliant countries see errata sheet included with control panel.			
The design, material and specifications are subject to change without notice.			

## FLOOR PLAN

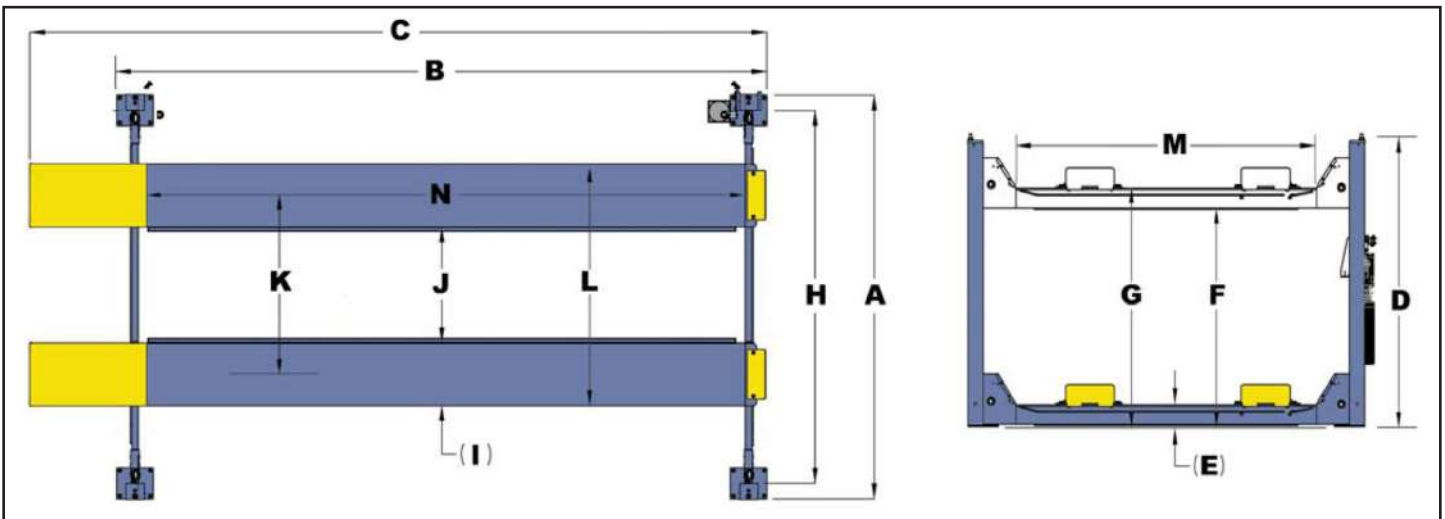

**\*IMPORTANT NOTE\***  
**Check Diagonal Measurements**  
**To Ensure Square Layout - Diagonal Measurements Must Be Equal.**

MODEL	HDS-40	HDS-40X
Lifting Capacity*	40,000 lbs. / 18,144 Kg.	40,000 lbs. / 18,144 Kg.
*Max Capacity / Front Axle	20,000 lbs. / 9,072 Kg.	20,000 lbs. / 9,072 Kg.
*Max Capacity / Rear Axle	20,000 lbs. / 9,072 Kg.	20,000 lbs. / 9,072 Kg.
A -Overall Width	154" / 3899 mm	154" / 3899 mm
B -Outside Length	257" / 6528 mm	317" / 8052 mm
C -Overall Length	313-1/2" / 7965 mm	373-1/2" / 9489 mm
D -Height of Columns	91-1/4" / 2318 mm	91-1/4" / 2318 mm
E -Min. Runway Height	9-1/2" / 240 mm	9-1/2" / 240 mm
F -Max. Rise	60" / 1524 mm	60" / 1524 mm
G -Max. Lifting Height	69-1/2" / 1764 mm	69-1/2" / 1764 mm
H -Width Between Columns	133-1/2" / 3391 mm	133-1/2" / 3391 mm
I -Runway Width	28" / 711 mm	28" / 711 mm
J -Width Between Runways (*) MIN	36" / 914 mm	36" / 914 mm
J -Width Between Runways (*) MAX	40-3/4" / 1035 mm	40-3/4" / 1035 mm
K -Runway Centerline (*) MIN	64" / 1625 mm	64" / 1625 mm
K -Runway Centerline (*) MAX	73-3/4" / 1873 mm	73-3/4" / 1873 mm
L -Outside Edge of Runways (*) MIN	92" / 2337 mm	92" / 2337 mm
L -Outside Edge of Runways (*) MAX	101-3/4" / 2585 mm	101-3/4" / 2585 mm
M -Drive-Thru-Clearance	109" / 2769 mm	109" / 2769 mm
N -Length of Runways	260-1/4" / 6610 mm	320-1/2" / 8141 mm
Min. Wheelbase @ Rated Capacity	185" / 4699 mm	230" / 5842 mm
Min. Wheelbase @ 75% Capacity	160" / 4064 mm	195" / 4953 mm
Min. Wheelbase @ 50% Capacity	135" / 3429 mm	165" / 4191 mm
Min. Wheelbase @ 25% Capacity	110" / 2794 mm	130" / 3302 mm
Locking Positions	13	13
Lock Spacing	Every 4" / 100 mm	Every 4" / 100 mm
Lifting Time	75 Seconds	75 Seconds
Standard Motor (***)	220 VAC / 60 Hz. 1Ph.	220 VAC / 60 Hz. 1Ph.
Emission sound pressure at Operator Position < 70 dB(A)		
* This dimension may be limited with the addition of rolling jacks. See Rolling Jack Specifications on Separate page.		
** For CE compliant countries see errata sheet included with control panel.		
The design, material and specifications are subject to change without notice.		

## CLEARANCES

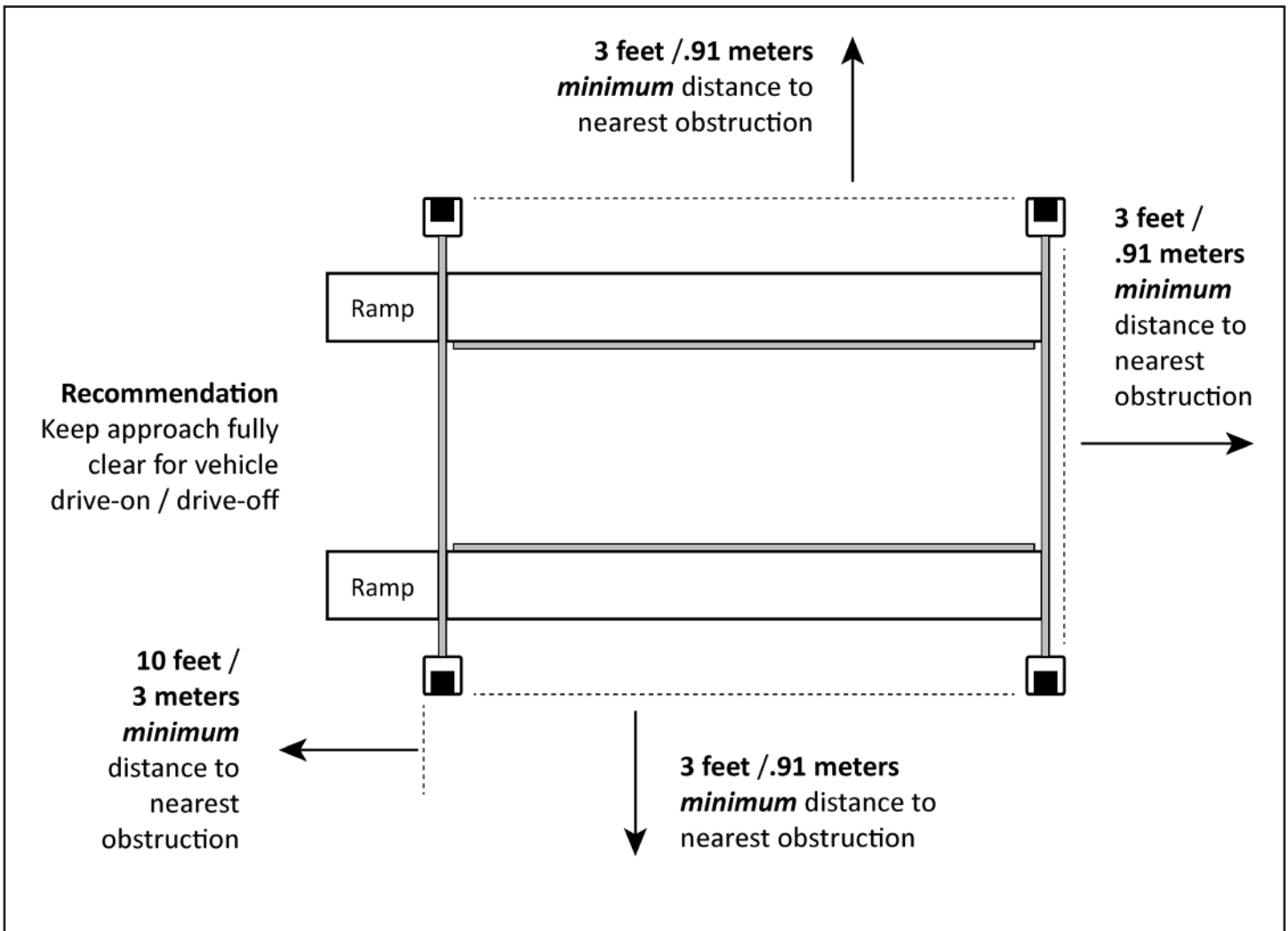

1. Lift Location: Use architects plan and Engineers automatic level (transit) when available to locate lift. The figure above shows clearances of a typical bay layout. Lift floor area should be level.

2. Ceiling or overhead clearance must be 80" plus height of tallest vehicle.

3. Estimating Column Shim requirements:  
In the following section, the terms "highest" and "lowest" refer to elevation of floor.

- A. Mark locations where lift columns will be positioned in bay.
- B. Place target on floor at column positions (NOT on column base plates) and record readings.
- C. Find the highest of the four locations. Find the difference between the readings at each of the remaining three columns and the highest reading.
- D. The difference is the estimated amount of shim thickness needed at each column.

Note: Maximum shim thickness is 1/2" per column using shims and anchors provided with lift.

If no transit is available, floor slope can be determined by using a chalk line and level.

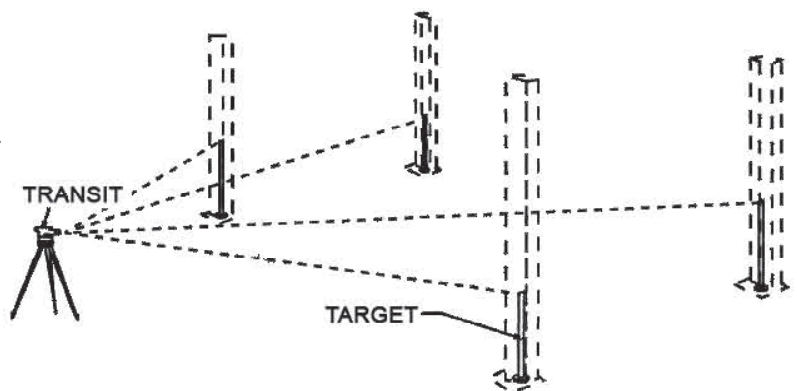

**COLUMN SHIM ESTIMATES**

# POWER UNIT LOCATION

## IMPORTANT NOTE !

The power unit can be located at either “ X ” location shown below. It is important to locate the POWERSIDE runway (with cylinder) on the SAME SIDE as the power unit location. Utility rails on the side of each runway MUST be installed facing the center. **For the remainder of this instruction the power unit will be illustrated mounted at the DRIVER-SIDE (LEFT) FRONT column - TOP ILLUSTRATION.** For power unit at right rear, rotate lift 180° leaving approach ramps and front tire stops in original position.

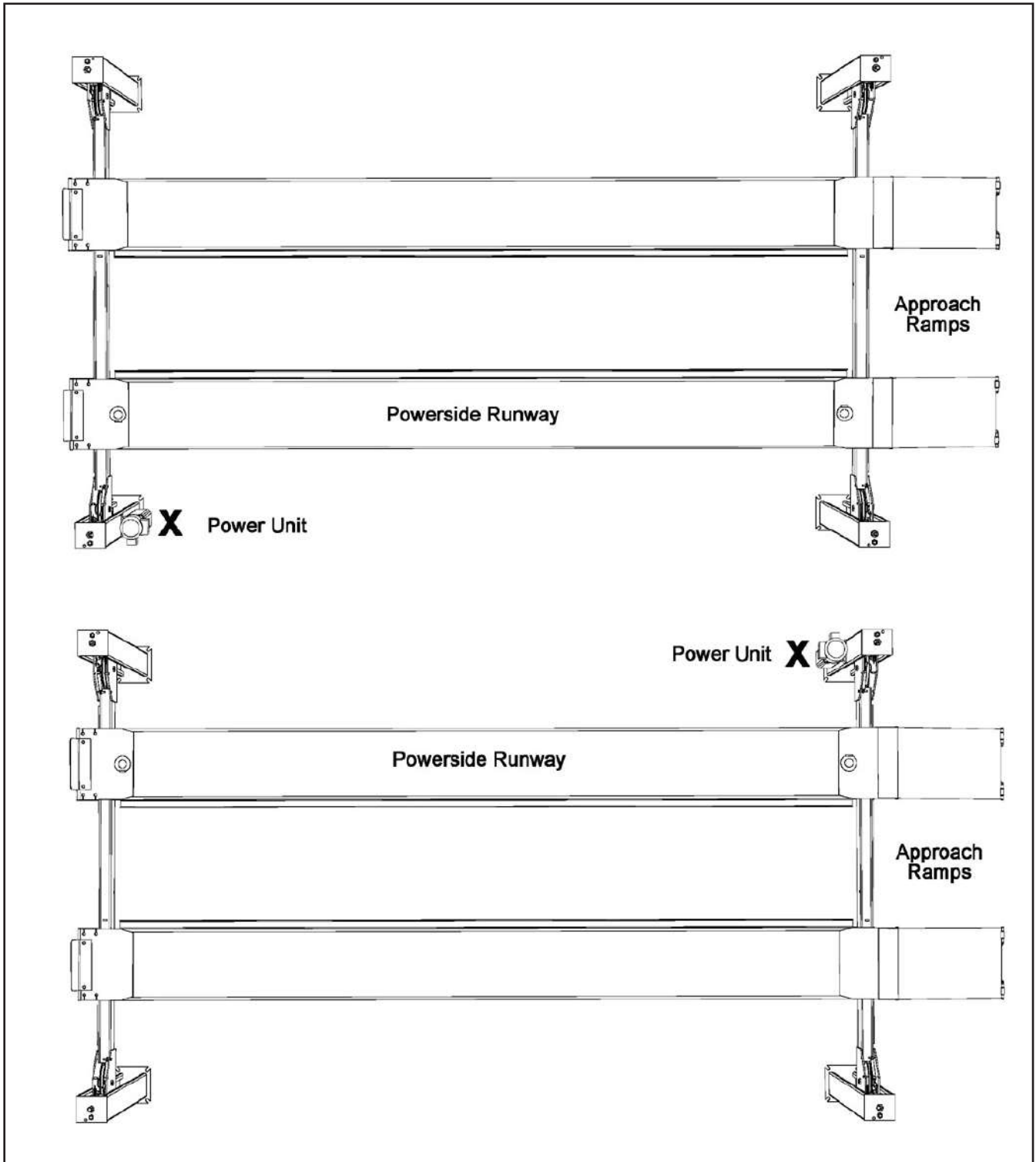

## STEP 3

(Column & Cross Tube Installation)

1. Place a chalk line on the floor according to the floor plan layout. Pay attention to the Power Unit location. Locate and stand the Columns at their respective locations. **DO NOT BOLT** Columns down at this time. Use caution to prevent the Columns from falling over. (See Fig. 3.1)

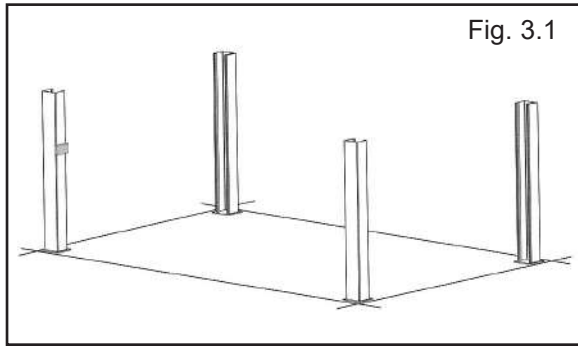

2. To estimate the shim requirements, place a target on floor at each Column position and record the readings. Find the highest of the four locations then find the difference between each of the remaining Columns. This difference is the estimated amount of shim thickness that will be required at each Column. (See Fig. 3.2)

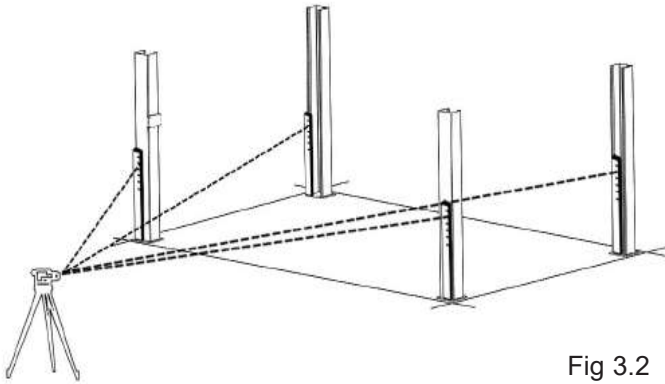

Note: The maximum shim thickness recommended by the factory is no more than 1/2" per Column using shims and anchors provided with the lift. A maximum shim thickness of 2" is possible by ordering optional Shim Plates. Contact your authorized BendPak Distributor for ordering information.

3. Using a forklift or crane, raise the Cross Tubes (making sure the Plastic Slide Blocks are still in position) and drop down into the top of the Columns. NOTE: The sheave windows should be positioned inward and adjacent the Power unit Column. (See Fig. 3.3)

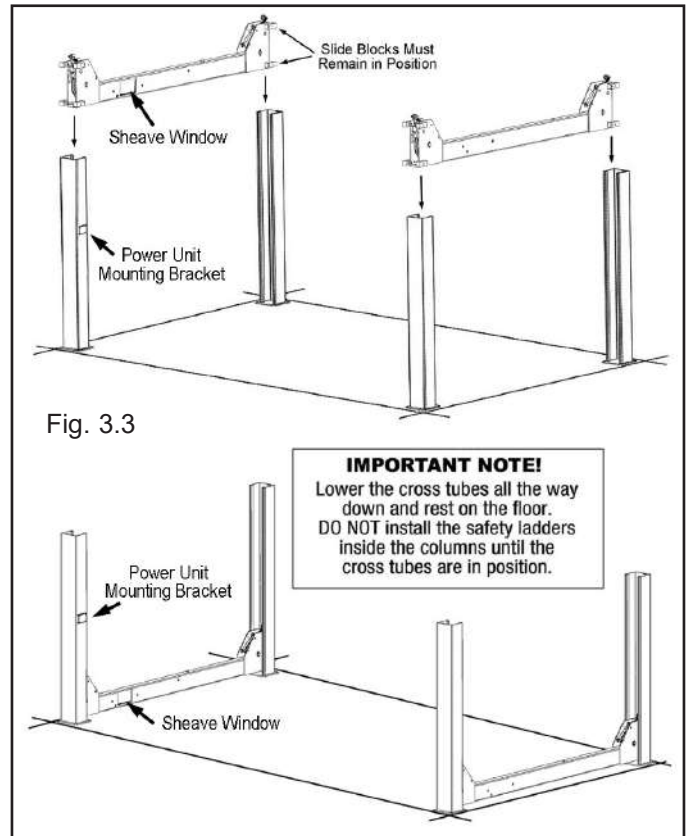

4. With the Columns standing and the Cross Tubes in position, install the Safety Ladders. Pass the Ladders through the Column openings and drop down through the Slide Block guide slots on the cross tube until the Ladders come to rest on the Base Plates. **DO NOT BOLT** Columns down at this time. (See Fig. 3.4 - 3.5)

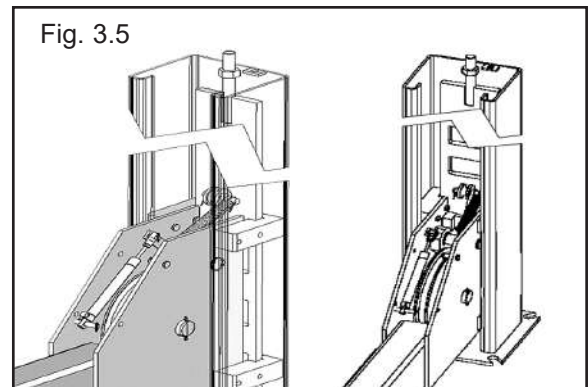
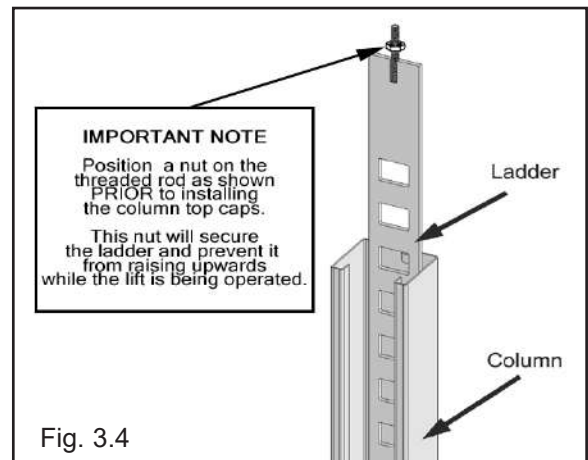

5. The Columns and Cross Tubes will now be in position and spaced properly for the runways.

6. Install the column TOP CAPS using the M16 X 2 Hex Bolts, nuts & washers. Install the nut on each Safety Ladder until 1/2" of threads are exposed and the Ladder is raised at least 1/2" off of the base of the Column.

**NOTE:** Raise the Ladder at least 1/2" off of the base of the column or damage to the lift will occur. Be sure to position the Cable hole INWARD. (See Fig. 3.6 - 3.7)

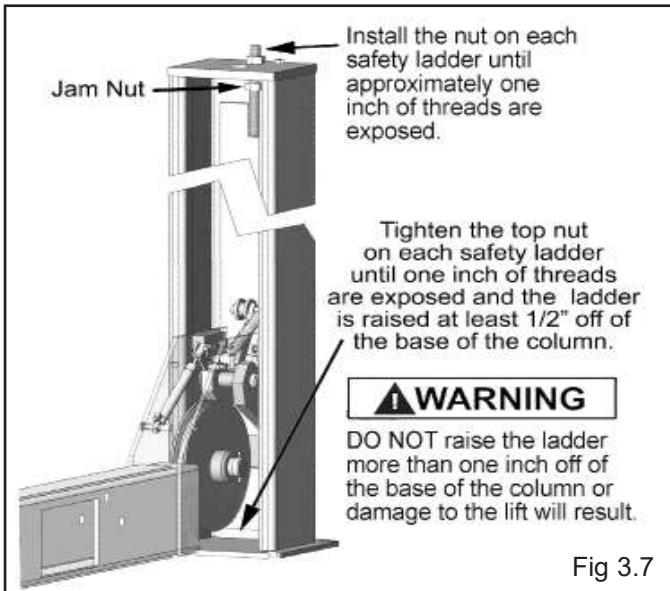
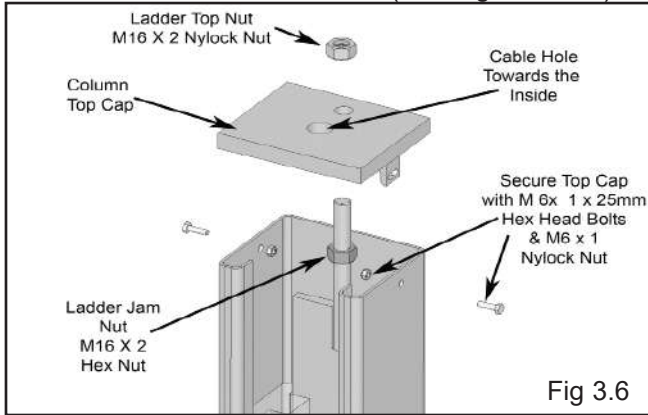

### STEP 4

(Raising The Cross Tubes)

1. Before proceeding it will be necessary to first raise the Cross Tubes off the ground to facilitate Cable routing and final assembly.



### DANGER !

Be careful not to disturb the Columns and Cross Tubes as they may tip over causing personal injury or harm.

### IMPORTANT NOTE !

It is important that the SLACK SAFETY LOCK IS CLEARED. The slack safety lock must never rest on the safety ladder.

2. Manually raise the Cross Tubes until the Primary Safety Locks engage and rest on the lock position second down from the top of the Ladder or approximately 66" off the ground. It is important that the SLACK SAFETY LOCK IS CLEARED. The Slack Safety Lock must never rest on the Safety Ladder. (See Fig. 4.1 -4.3)

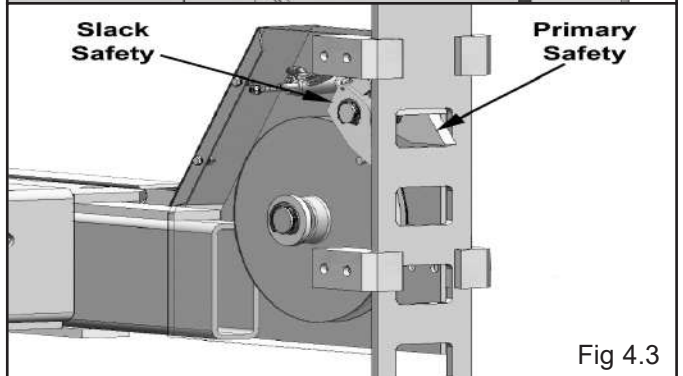
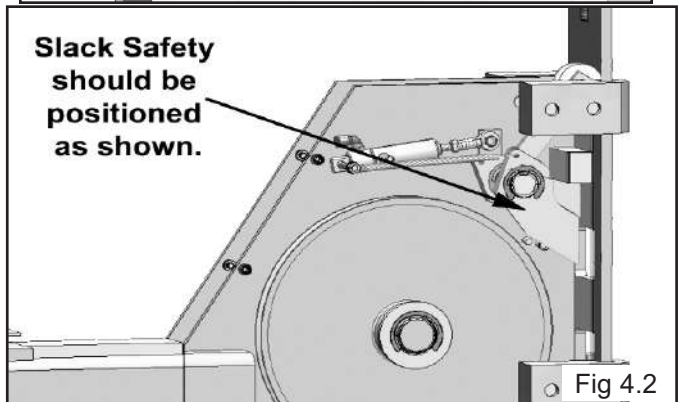
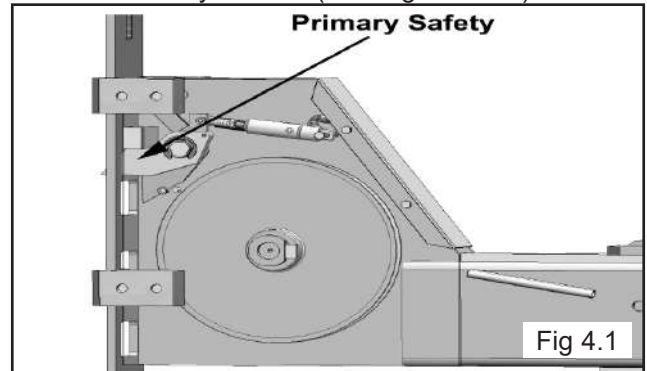

3. The Columns and Cross Tubes will now be in position and spaced properly for the Runways. Be very careful not to disturb the Columns and Cross Tubes at this time as they may tip over causing personal injury or harm.

(See Fig. 4.4)

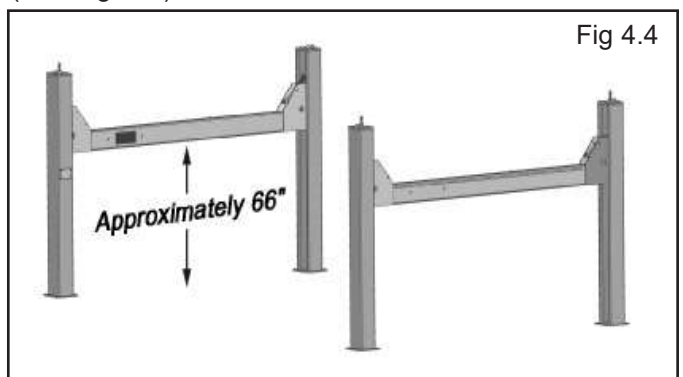

## STEP 5

(Powerside Runway Installation)

1. Locate the POWERSIDE RUNWAY, easily identified by the Cylinder and Sheave roller mounting structures welded on the underside. The Powerside Runway will be positioned on the side of the lift where the Power Unit is installed.

(See Fig. 5.1)

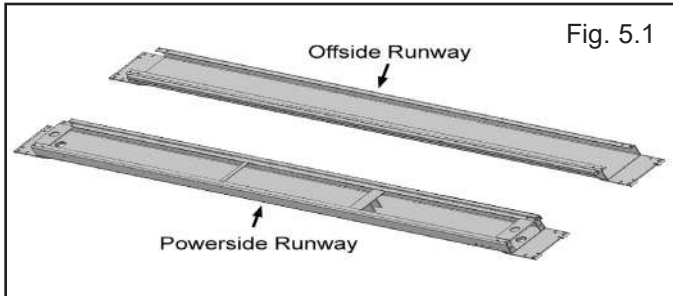

2. Install the Cylinder and Cable Block as shown. Ensure the snap ring is installed on the cylinder rod. (See Fig. 5.2 - 5.3)

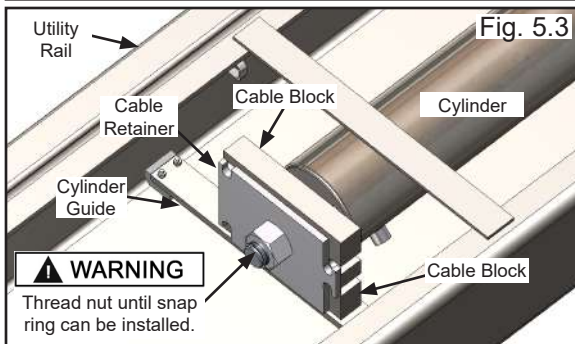
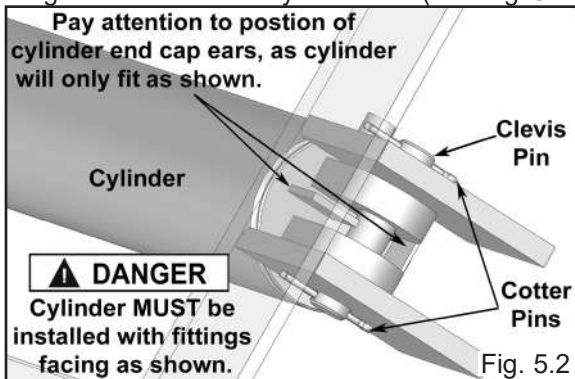

3. Remove any pre-installed CABLE SHEAVES and SPACERS from the POWERSIDE RUNWAY making sure to and pay attention to the order in which they are removed. (This will help at the time of re-installation.) First remove the Retaining Pin then press the Sheave Axle through the Runway completely until the Sheaves and Spacers are removed. (See Fig. 5.4)

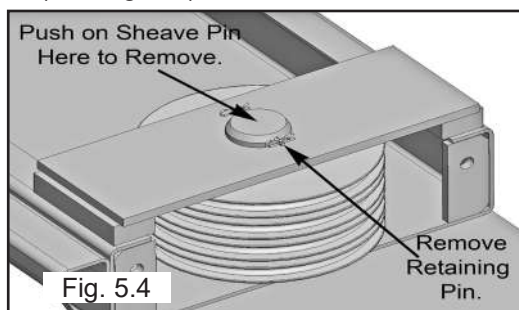

4. Position the POWERSIDE RUNWAY on top of the Cross Tubes with the UTILITY RAIL towards the center. The fitting holes located at the side of the Powerside Runway should be adjacent the POWER UNIT COLUMN. Align the holes in the Runway with the holes on the Cross Tubes and bolt together using four M18 x 2.5 hex bolts and washers. (See Fig. 5.5)

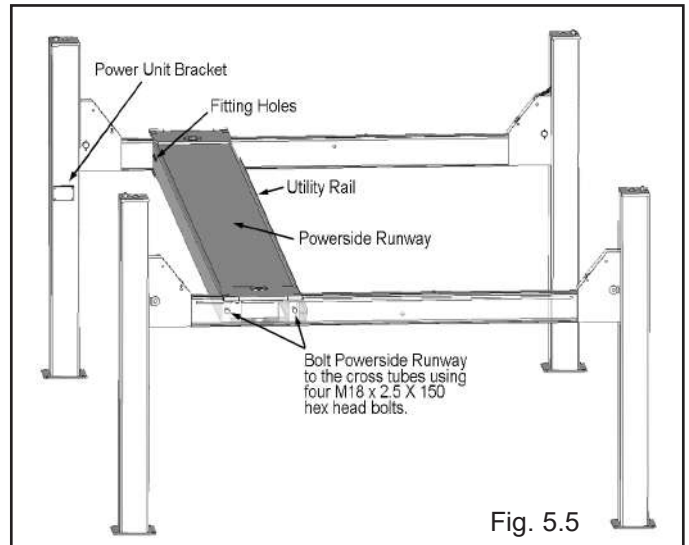

## STEP 6

(Offside Runway Installation)

1. Position the OFFSIDE RUNWAY on top of the Cross Tubes with the UTILITY RAIL located inside.

(See Fig. 6.1)

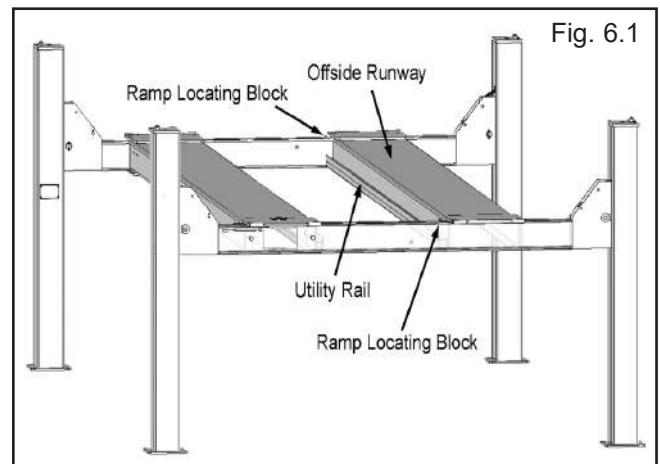

## STEP 7

(Sheave Installation)



### DANGER !

**DO NOT PROCEED** with Cable installation or go near the lift work area unless visual confirmation is made of ALL Safety Locks. ALL locks MUST be engaged before proceeding. Failure to comply with these instructions may result in severe personal injury or death. (See page 26.)

# ⚠ WARNING

**WARNING!**

WHEN THE CABLE ADJUSTING NUTS BOTTOM OUT ON THE THREADED END OF THE CABLE CONNECTOR AND THERE IS STILL SLACK IN THE CABLES, THE CABLES HAVE STRETCHED BEYOND THE SAFE USEFUL LENGTH AND NEED TO BE REPLACED WITH FACTORY APPROVED CABLE ASSEMBLIES. DO NOT PLACE WASHERS, SPACERS OR OTHER DEVICES TO "SHORTEN" THE EFFECTIVE CABLE LENGTH AS DAMAGE TO THE LIFT OR INJURY TO PERSONS MAY OCCUR.

1. Inspect cables to insure proper lengths. All CABLES should have ID tags showing proper Cable lengths.
2. In order to install the Cables it is necessary to first extend the HYDRAULIC CYLINDER. Remove both Cylinder port plugs then use an air gun or come-along to extend the Cylinder. **IMPORTANT!** - Be careful not to damage the chrome rod during this step. (See Fig. 7.1)

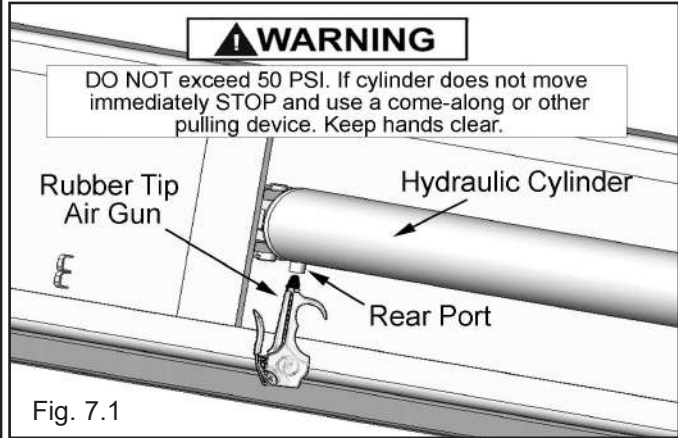

3. You must reinstall the SHEAVES, SPACERS AND PINS in the same order as they are removed. Note: Failure to install PLASTIC FRICTION SPACERS will result in premature sheave wear and void warranty. (See Fig. 7.2 & 7.3.)

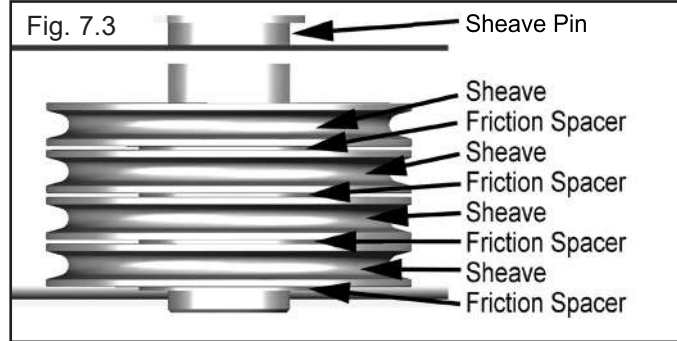
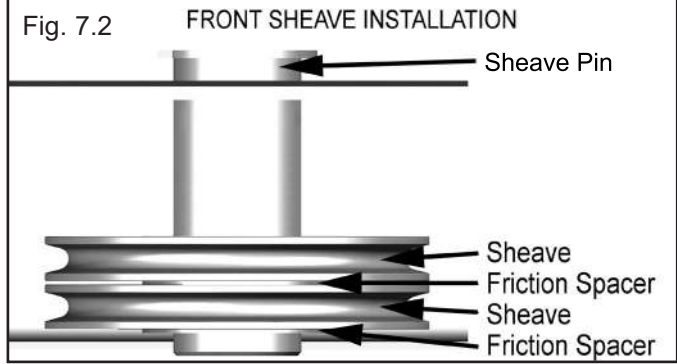

**HELPFUL TIP**

Install the Sheaves and Cables in the order as shown below starting from the SHORTEST (A) to the LONGEST (D).

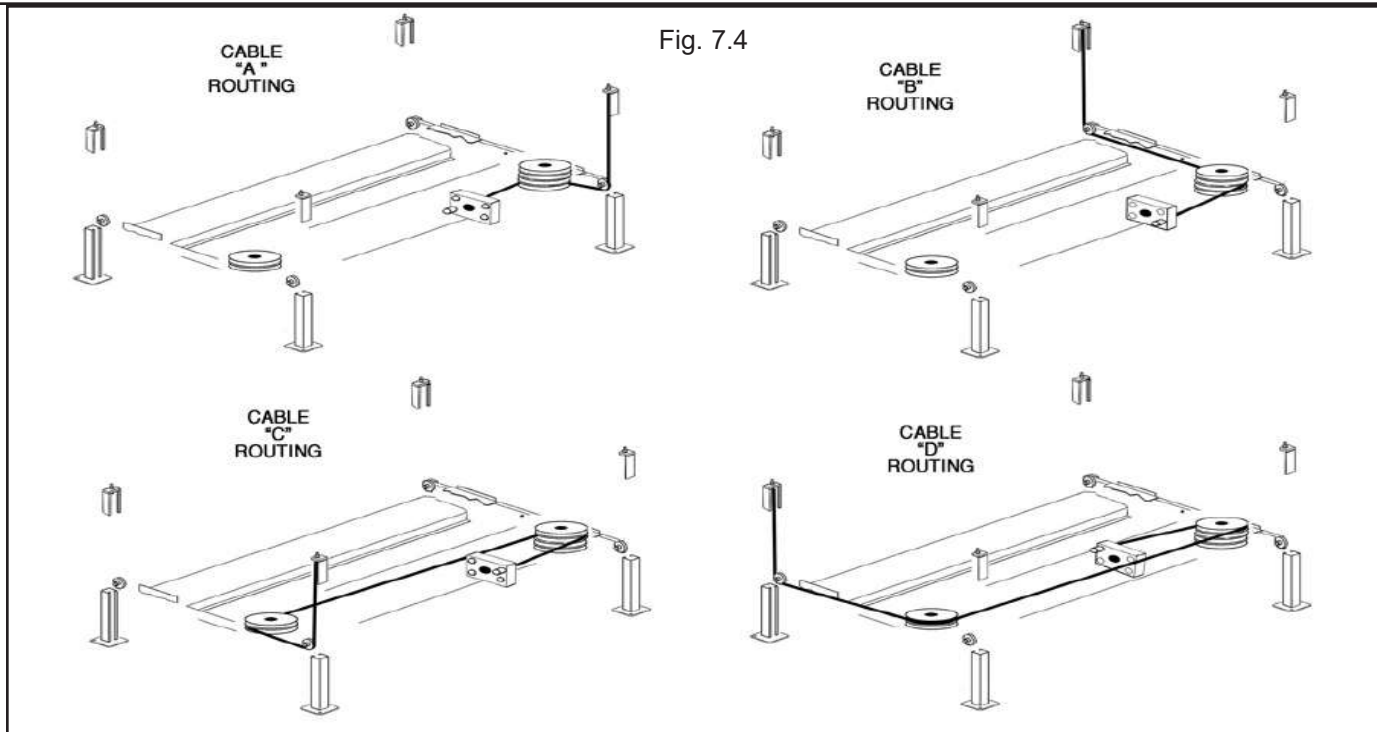



**! DANGER**

**DANGER !**  
**DO NOT PROCEED** unless visual confirmation is made of ALL Safety Locks. ALL locks **MUST** be engaged before proceeding. Failure to comply with these instructions may result in severe personal injury or death. (See page 25.)

4. With the CABLES properly routed, hold the Sheaves in position and install the SHEAVE PIN. (See Fig. 7.5)

Stack Cables and Sheaves in proper order and make ready for the Sheave Pin.

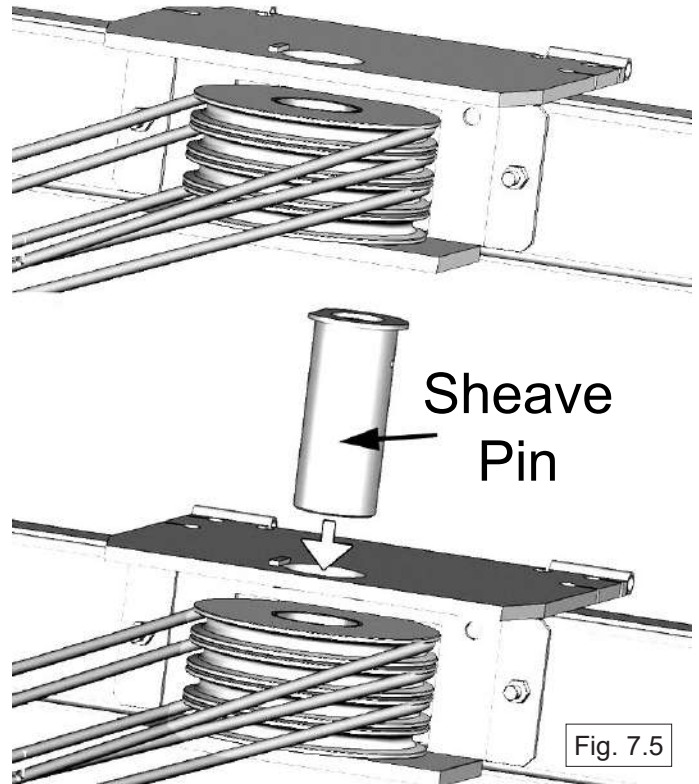
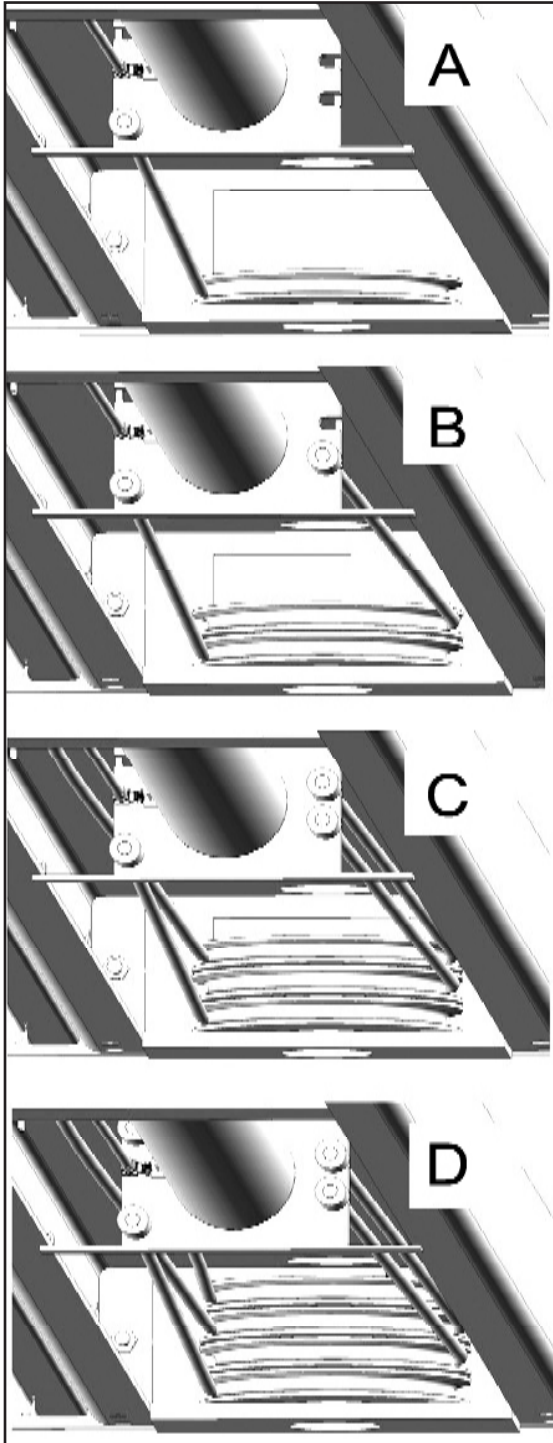

5. Repeat the same procedure at the other end of the lift starting with the bottom Sheave and Cable first. Be sure that you install the Sheaves, Spacers and Pins in the same order as they are removed.

6. Install the Sheave Pin Retaining Pin and Hair Pins through the bottom of the Sheave Pin.

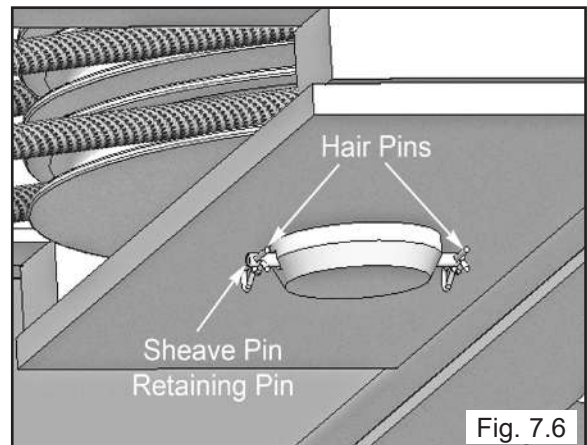

7. Each cable must be installed through the CABLE RETAINER first to keep Cables stowed in their proper position on the Cable Block. (See Fig. 7.7)

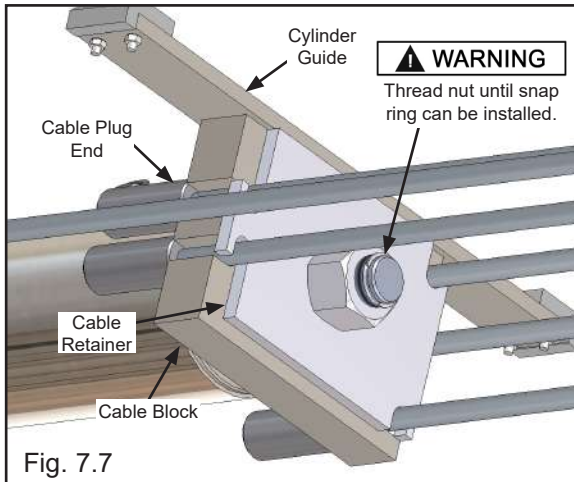

8. Route the Cable ends through the ends of each Cross Tube, over the SLACK SAFETY SHEAVE then to the top of each column. Secure using the M30 Hex Nuts and Flat Washers. Tighten each nut until there is at least one inch of threads protruding through the top of the nut. The Cables will remain loose until start up and final Cable adjustments are made. (See Fig. 7.8 & 7.9)

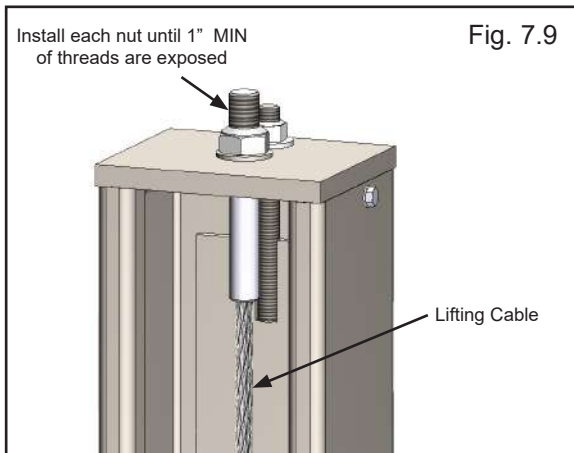
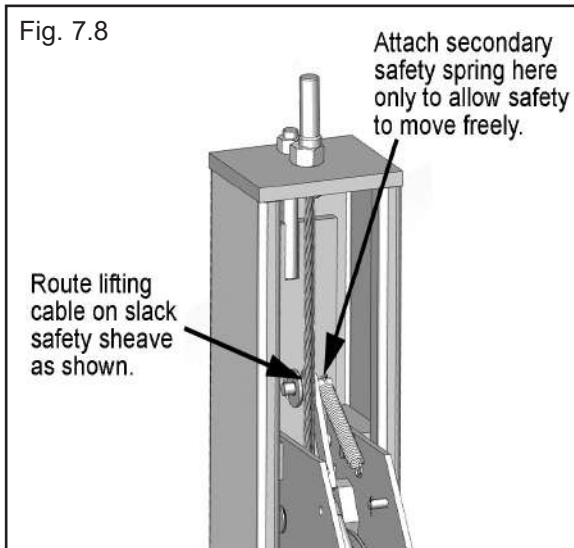

9. After routing the Cables double-check to make sure all are properly positioned and REMAIN WITHIN THE GROOVES of ALL Sheaves. (See Fig. 7.10. & 7.11)

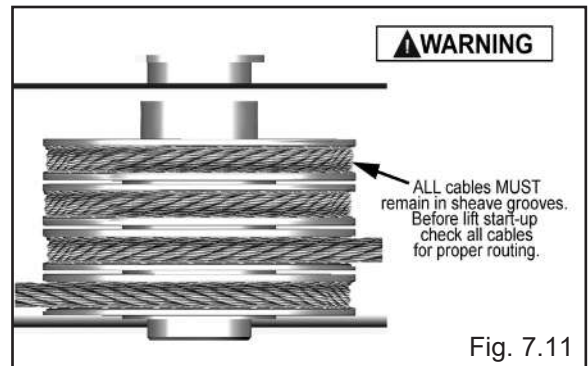
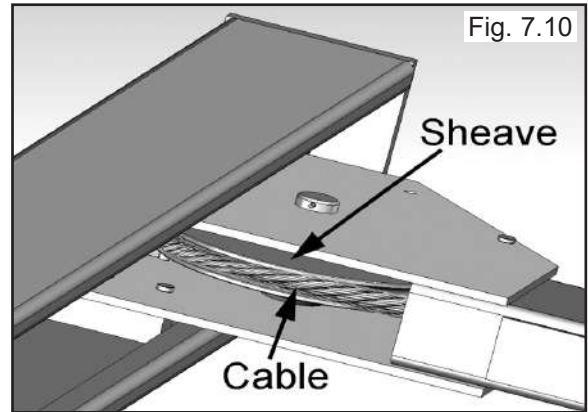

**! DANGER**

**DANGER!**  
Lifting Cables routed through the Cross Tubes must run BELOW the Cross Tube Mounting Bolts. Serious damages or injury can occur if Cables are not routed correctly. (See Fig 7.12)

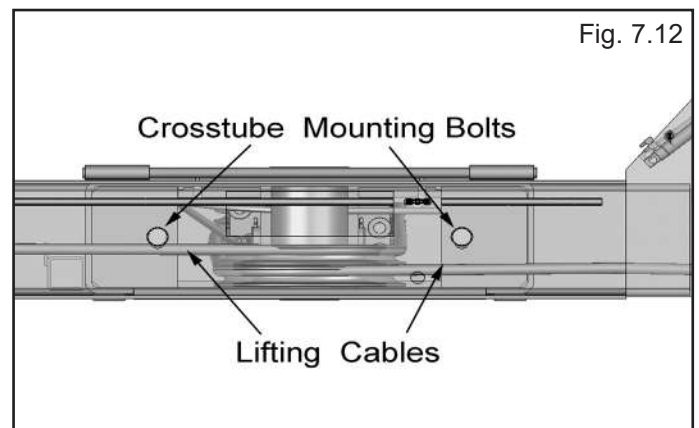

**! DANGER**

**DANGER !**  
Failure to route Lifting Cables as described may lead to serious personal injury and/ or death to operator or bystander and/ or may cause damage to property.

**⚠ DANGER**

**DANGER !**  
**ALL WIRING MUST BE PERFORMED**  
**BY A LICENSED ELECTRICIAN.**



**DANGER!**  
**DO NOT PERFORM ANY MAINTENANCE OR**  
**INSTALLATION OF ANY COMPONENTS WITH OUT**  
**FIRST ENSURING THAT ELECTRICAL POWER HAS**  
**BEEN DISCONNECTED AT THE SOURCE OR PANEL**  
**AND CANNOT BE RE-ENERGIZED UNTIL ALL**  
**MAINTENANCE AND/ OR INSTALLATION**  
**PROCEDURES ARE COMPLETED.**

**STEP 8**  
 (Power Unit Installation)

1. Mount the POWER UNIT to the Mounting Bracket using the M10 Hex Bolts and Nylock nuts then FILL THE RESERVOIR with 20-quarts of 10-WT hydraulic oil or Dexron automatic transmission fluid. (See Fig. 8.1)

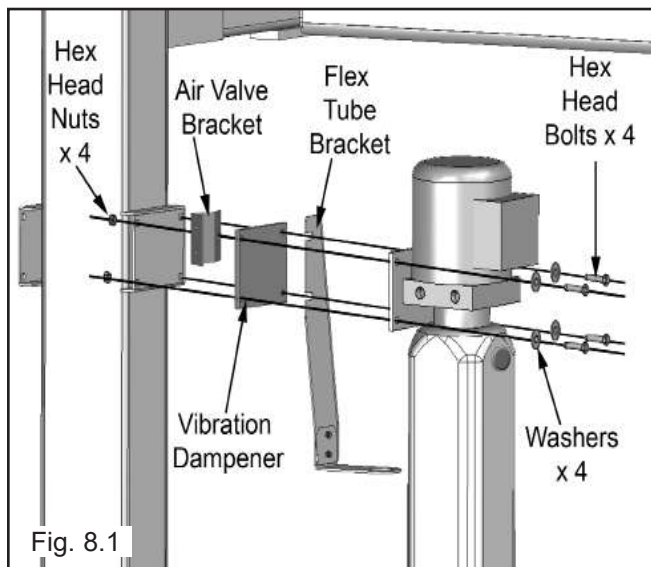

Fig. 8.1

**STEP 9**

(Routing Hydraulic Hoses)

**NOTE:**  
**POWER AND RETURN PORT LOCATIONS MAY**  
**VARY. CONFIRM POWER AND RETURN PORT**  
**LOCATIONS IN POWER UNIT DOCUMENTATION**  
**OR CONTACT TECHNICAL SUPPORT.**

1. Install the 90-degree Hydraulic Fitting to the POWER PORT and the 90° Air Line Compression Fitting to the RETURN PORT of the Power Unit and connect the Hoses as described below. It will be necessary to remove the shipping plugs from both ports prior to installing the Fittings. On the pipe thread side of the fitting it is recommended to use Teflon tape or pipe sealer. **DO NOT USE TEFLON TAPE** on the JIC flared end. It will be necessary to remove the shipping plugs from both ports prior to installing the fittings. (See Fig. 9.1 -9.2)

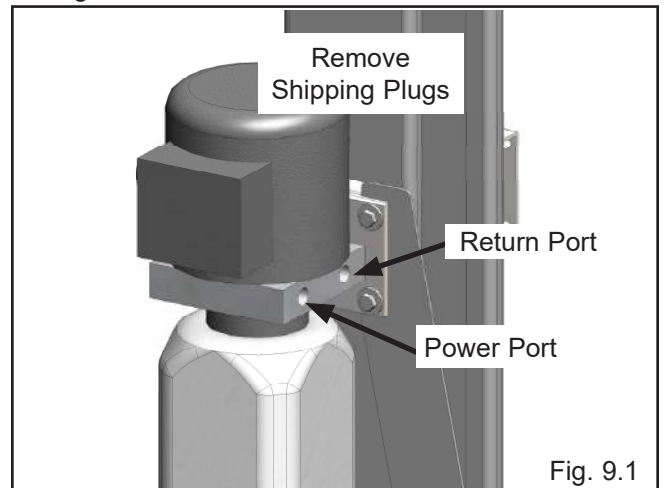

Fig. 9.1

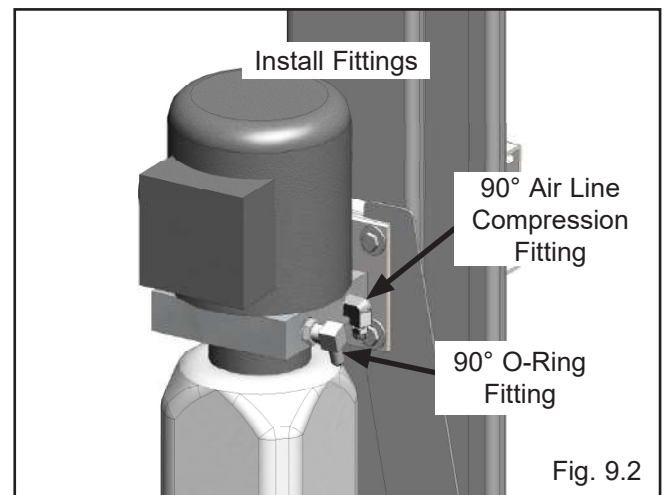

Fig. 9.2

2. Remove the captive nut on the Compression Fitting. Insert the Plastic Air line through the alignment sleeve and into the end of the fitting until it bottoms out. Then tighten the nut on the fitting. (See Fig 9.3)

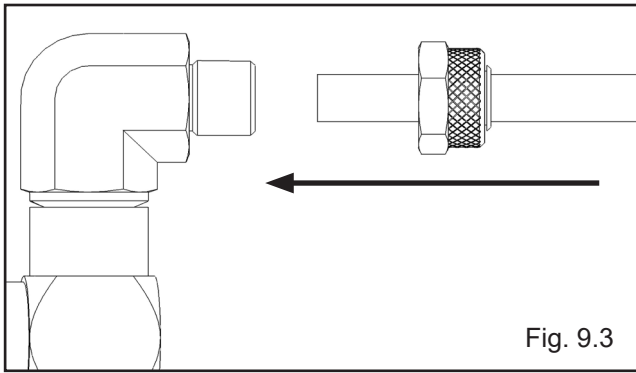

Fig. 9.3

3. Install the 90° Hydraulic Fittings in the port at the ram end of the cylinder. On the pipe thread side of the fitting it is recommended to use Teflon tape or pipe sealer. **DO NOT USE TEFLON TAPE** on the JIC flared end. (See Fig. 9.4 )

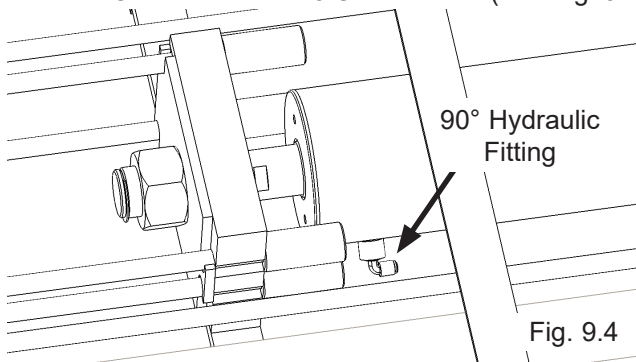

Fig. 9.4

4. Install the 90° Air Line Compression Fitting in the port at the base, pinned end of the Cylinder. On the pipe thread side of the Fitting, it is recommended to use Teflon Tape or pipe sealer. (See Fig. 9.5)

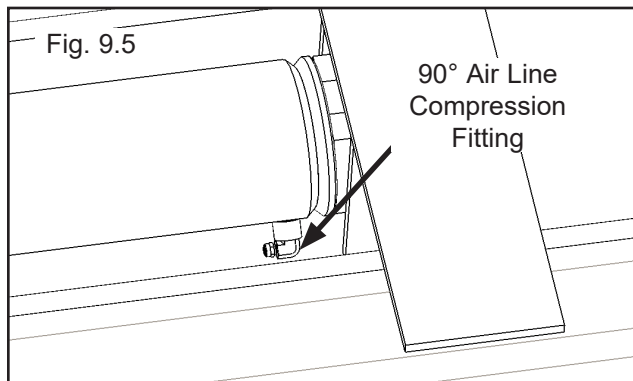

Fig. 9.5

5. Route both the Power Unit Hydraulic Hose and TWO (2) lengths of Air Line through the Flex Hose. (See Fig. 9.6)

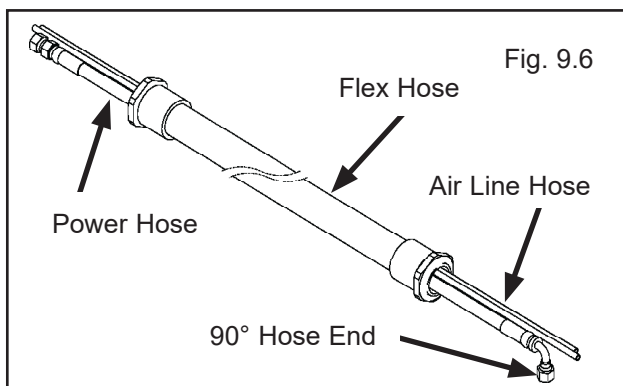

Fig. 9.6

6. Install the end of Flex Hose with the Straight Fitting on the Hydraulic Hose into the hole in the Powerside Runway adjacent to the Power Unit. Install the end of the Flex Hose with the 90° Fitting on the Hydraulic Hose in the Flex Hose Bracket Assy. Tighten the plastic nuts securely. (See Fig 9.7)

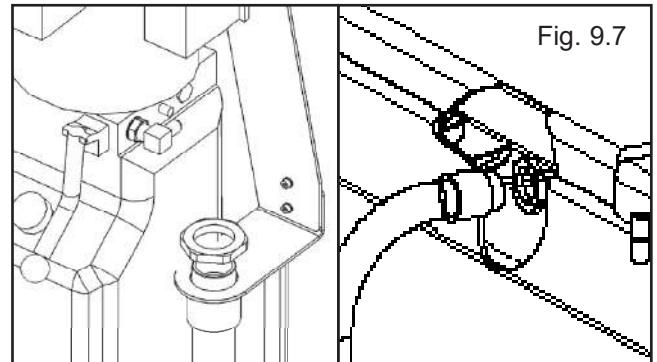

Fig. 9.7

7. Connect the hydraulic hose and air line as shown below making sure the hydraulic hose passes through the retaining rings. **MAKE SURE HOSES ARE KEPT CLEAR OF CABLES.** There will be one air line hose left unconnected in this step. This air line will be used to activate the pneumatic safety locks in the next step. See Fig 9.3 for Compression Fitting instructions. (See Fig. 9.8)

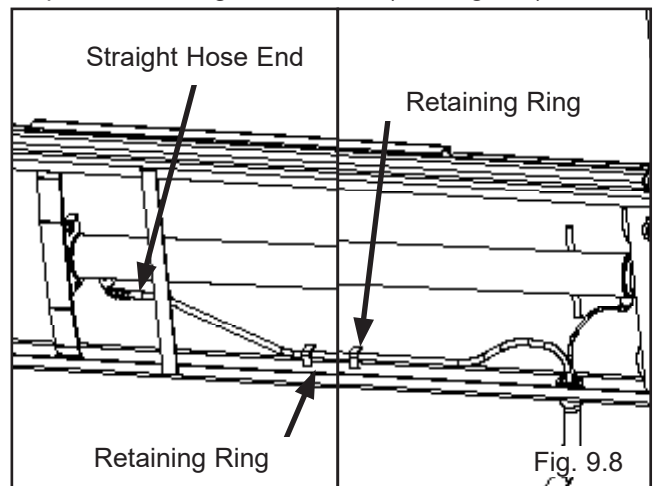

Fig. 9.8

8. Connect the 90° end of the Power Unit Hydraulic Line to the 90° Power Unit Fitting. Connect the Return Air Line to the 90° Air Line Compression Fitting. There will be one air line hose left unconnected at this time. This air line hose will be used to activate the pneumatic safety locks on the next page. (See Fig. 9.9)

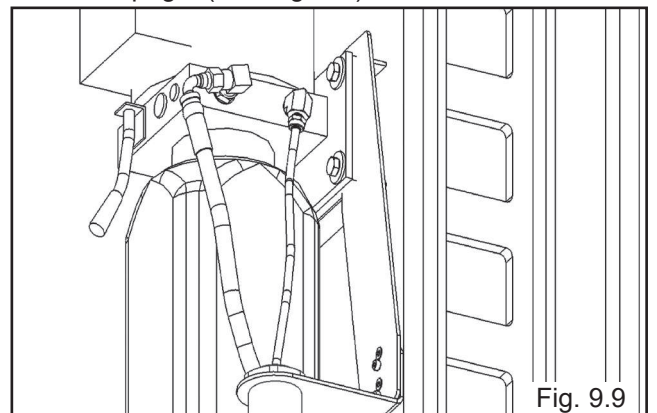
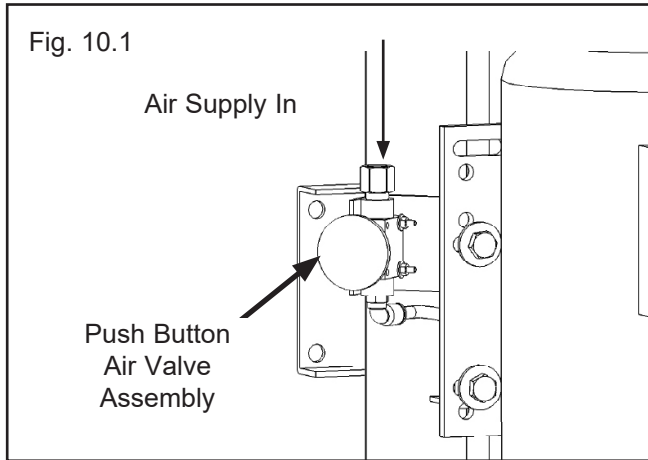

Fig. 9.9

## STEP 10

( Routing Air Lines)

1. Mount the Push Button Air Valve Assembly on to the power unit mounting bracket. The Push Button Air Valve should be positioned away from the Power Side Ramp on the “out” side of the lift for operator safety. (See Fig 10.1)



2. Route the air line that was left unconnected in Step 10 to the 90° Air Line Compression Fitting of the Push Button Air Valve Assembly. (See Fig 10.2)

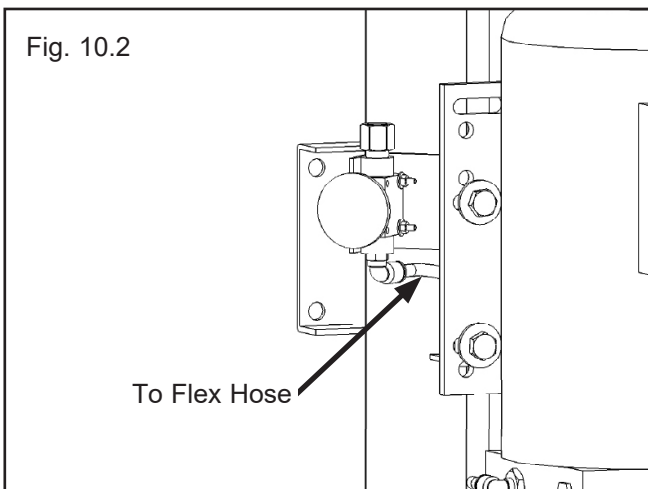

3. Once the air line has been connected with the Push Button Air Valve, cut the air lines to length by following the Safety Air Line Routing diagram located on Page 22 and connect female branch “tee” fittings where needed.

### NOTE:

MAKE SURE THE PUSH BUTTON AIR VALVE PORT MARKED “INLET” IS FACING TOWARDS THE SOURCE OF COMPRESSED AIR.

### NOTE:

A FILTER/REGULATOR/LUBRICATOR MUST BE INSTALLED ON AIR SUPPLY AT LIFT. FAILURE TO DO SO WILL VOID THE WARRANTY.

## SAFETY AIR LINE ROUTING

### NOTE:

CUT THE PROVIDED 1/4" AIR LINE TUBING WITH A SHARP BLADE TO LENGTHS AS REQUIRED. TUBING MUST BE CUT SQUARE WITH ALL PLASTIC BURRS REMOVED.

### AIR TUBING ASSEMBLY:

SEE PAGE 20 FOR ASSEMBLY OF AIR LINE TUBING INTO FITTING.

### CAUTION:

REMOVING THE AIR TUBING FROM THE COMPRESSION FITTINGS WILL CAUSE DAMAGE TO THE TUBING ITSELF. USE OF A DAMAGED AIR LINE MAY RESULT IN SAFETY LOCK FAILURE.

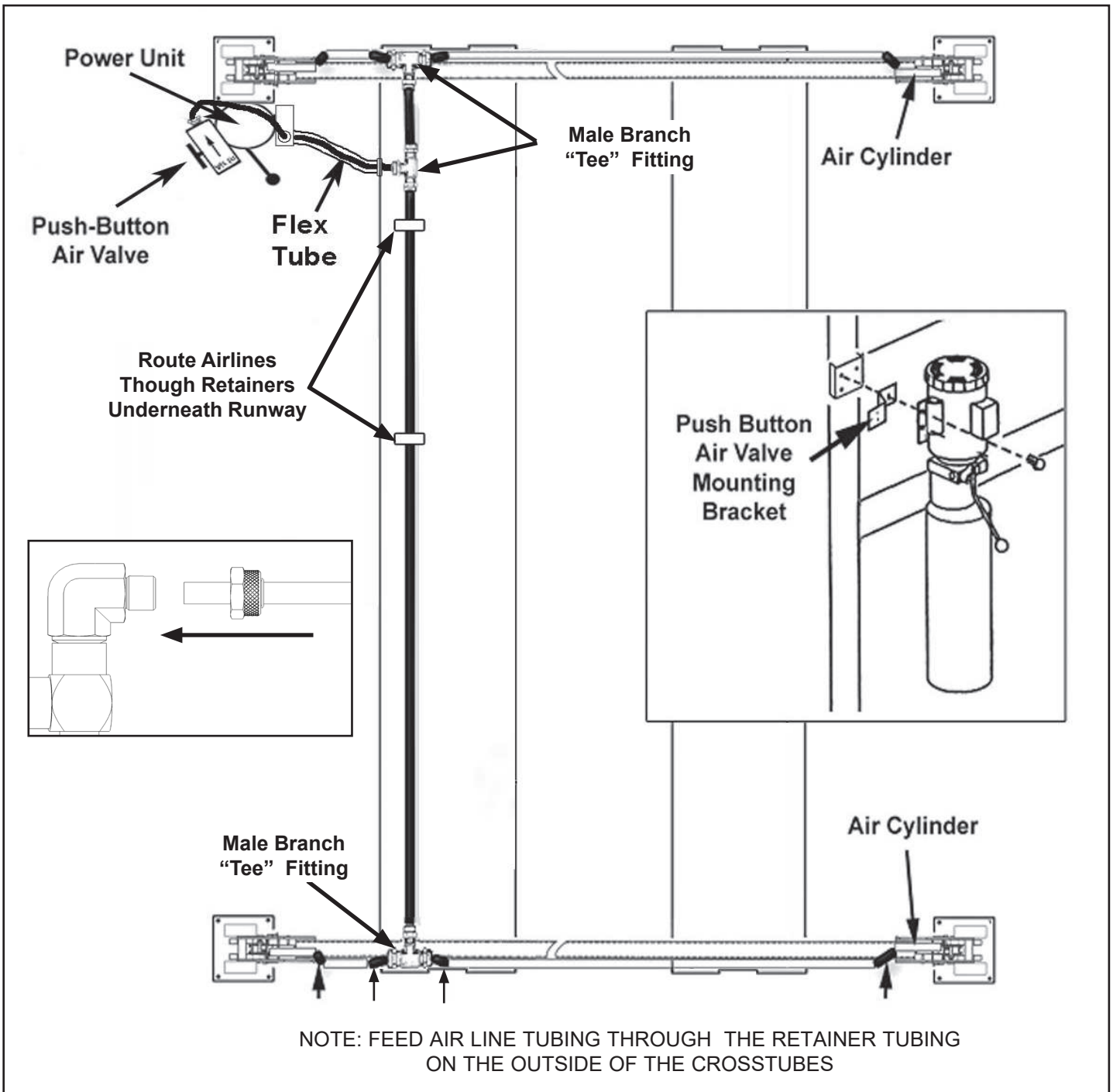



### **DANGER!**

**DO NOT PERFORM ANY MAINTENANCE OR INSTALLATION OF ANY COMPONENTS WITHOUT FIRST ENSURING THAT ELECTRICAL POWER HAS BEEN DISCONNECTED AT THE SOURCE OR PANEL AND CANNOT BE RE-ENERGIZED UNTIL ALL MAINTENANCE AND/OR INSTALLATION PROCEDURES ARE COMPLETED.**



## **IMPORTANT POWER-UNIT INSTALLATION NOTES**

- DO NOT run power unit with no oil. Damage to pump can occur.
- The power unit must be kept dry. Damage to power unit caused by water or other liquids such as detergents, acid etc., is not covered under warranty.
- Improper electrical hook-up can damage motor and will not be covered under warranty.
- Motor can not run on 50HZ without a physical change in motor.
- Use a separate breaker for each power unit.
- Protect each circuit with time delay fuse or circuit breaker.
- For 208-230 volt, single phase, use a 25 amp fuse.
- For 208-230 volt, three phase, use a 20 amp fuse.
- For 380-440 volt, three phase, use a 15 amp fuse.

Installation and adjustment.

DO NOT attempt to raise vehicle until a thorough operation check has been completed.

**All wiring must be performed by a certified electrician only.**

Identify which Power Unit the lift was shipped with by looking on the data tag affixed to the Power Unit motor head. If the model number begins with the letter "S" then use the "S" wiring diagrams. If the model number begins with the letter "E" or "F" then use the "E" or "F" wiring diagrams.

**SEE WIRING INSTRUCTIONS AFFIXED TO  
MOTOR FOR PROPER WIRING INSTRUCTIONS.**

# “S” MODEL

## Single Phase 220V

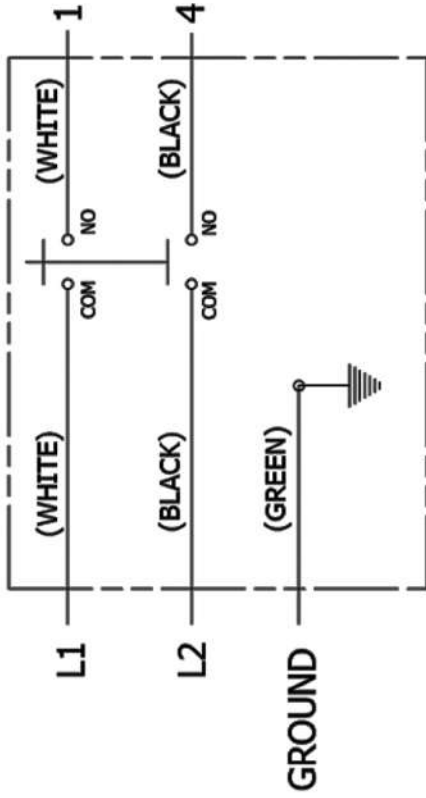

# “S” MODEL

## Three Phase 220V

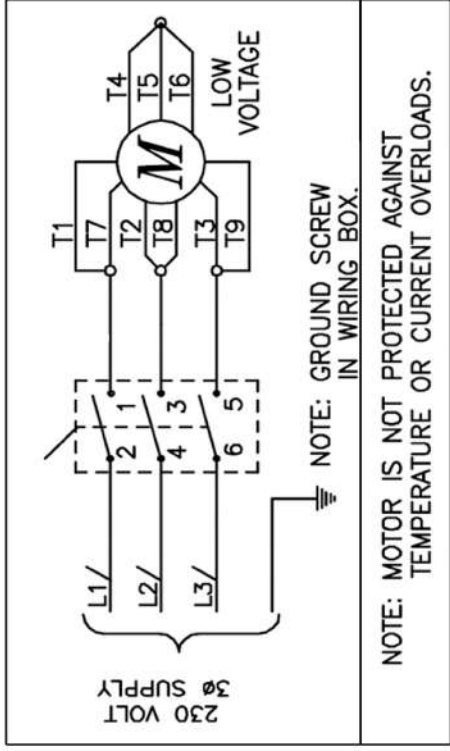

# “E” or “F” MODEL

## Single Phase 220V

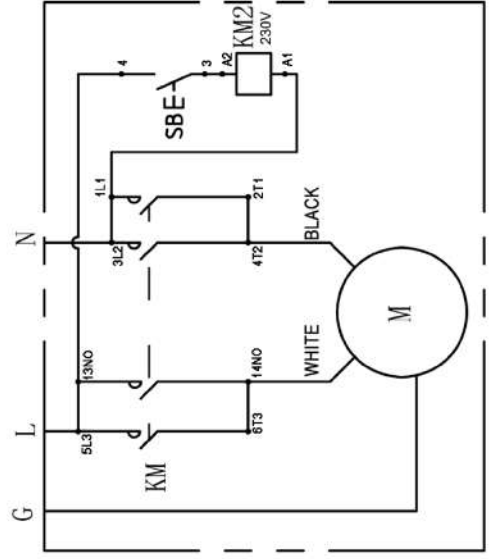



## STEP 11

(Power Unit Hook Up)

1. Have a CERTIFIED ELECTRICIAN run the power supply to motor. Refer to the data plate found on the motor for proper power supply and wire size.



### RISK OF EXPLOSION!

This equipment has internal arcing or PARTS THAT MAY SPARK and should not be exposed to flammable vapors. Motor should not be located in a recessed area or below floor level. NEVER expose motor to rain or other damp environments. DAMAGE TO MOTOR CAUSED BY WATER IS NOT COVERED UNDER WARRANTY.

#### IMPORTANT NOTE:

CAUTION Never operate the motor on line voltage less than 208V. Motor damage may occur which is not covered under warranty. Have a certified electrician run appropriate power supply to motor. Size wire for 25 amp circuit. See Motor Operating Data Table.

IMPORTANT: Use separate circuit for each power unit. Protect each circuit with time delay fuse or circuit breaker. For single phase 208-230V, use 25 amp fuse. Three phase 208-240V, use 25 amp fuse. For three phase 400V and above, use 15 amp fuse. All wiring must comply with NEC and all local electrical codes.

Fig. 11.1

### POWER UNIT

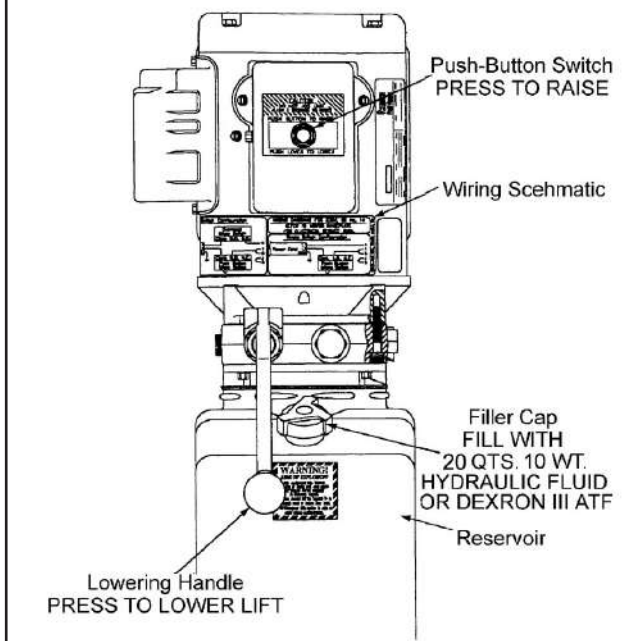

Typical Power Unit shown, controls and labels may vary.

## STEP 12

(Installing The Slack Safety Springs)



The following steps involve the SLACK CABLE SAFETY DEVICE and MAIN SAFETY. Failure to follow these steps could result in serious injury or death in the event of cable failure.

1. Install the unattached end of the ALL SAFETY LOCK SPRINGS as shown. Make sure the spring ends are secure at both ends. **DO NOT ATTEMPT TO RAISE THE LIFT UNTIL THE SLACK SAFETY SPRINGS ARE ATTACHED AND THE ROLLERS ARE PULLED CLEAR FROM THE LADDER.** (See Fig. 12.1)

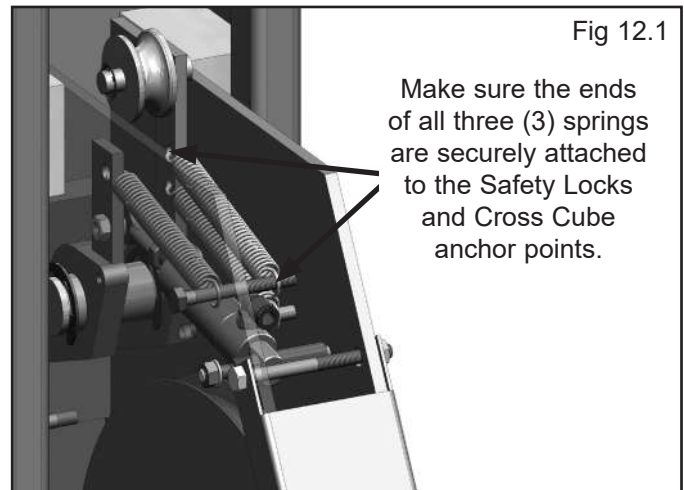

2. Repeat this step for each corner of the lift.

## STEP 13

(Lift Start Up / Final Adjustments)

1. Make sure the POWER UNIT RESERVOIR is full with 20-quarts of 10-WT hydraulic oil or Dexron automatic transmission fluid.
2. Spray the inside of the Columns where the Slide Blocks glide with a light lubricant or WD-40.
3. Test the Power Unit by pressing the push-button switch. If the motor sounds like it is operating properly, raise the lift and check all hose connections for leaks. If the motor gets hot or sounds peculiar, stop and check all electrical connections.
4. Before proceeding, double-check to make sure all Cables are properly positioned within the grooves of ALL sheaves. Make sure all cable sheave retaining pins and/ or clips are secure.

5. Check to make sure that all Slack Safety locks are cleared and free. (See Fig. 13.1)

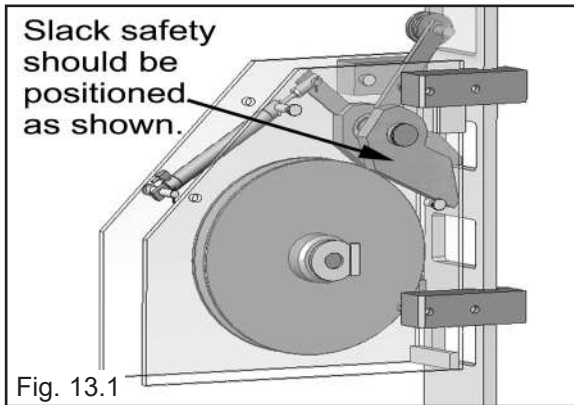

6. Continue pressing the raise button until the Cables get taugth and the lift starts to move.

7. Raise lift until the lift stops and lower until the Safeties engage the Top Locking Position. Adjust each ladder so that each Safety Lock rests on the corresponding Top Lock Position. Then adjust each Cable Nut so that each Safety Lock is ONE INCH (1") above the Top Lock Position. The Cable Nuts MUST be tightened until there is at least one inch of threads protruding through the nut. (See Fig. 13.2) Failure to do so could result in serious injury or death.

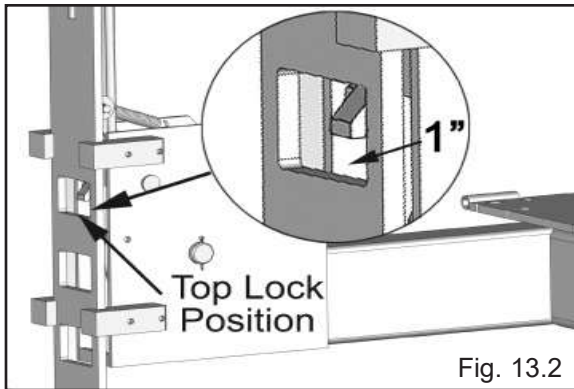

## WARNING

All cable nuts MUST be tightened on each end until there is at least one inch of threads protruding through the nut. Failure to do so could result in serious injury or death.

### NOTE:

There will be initial stretching of the cables in the beginning and/ or with increased loads. Adjust the cables as outlined above a week after first use, then every three to six months thereafter depending on usage and/ or to compensate for stretch.

8. After connecting the air supply, press the PUSH BUTTON AIR VALVE and check that all Safety Locks are functioning properly. Lower the lift by pressing the push button air valve and Power Unit lowering valve simultaneously.

## WARNING

**KEEP HANDS AND FEET CLEAR.** Remove hands and feet from any moving parts. Keep feet clear of lift when lowering. Avoid pinch points.

9. Check all MAIN SAFETY LOCKS to make sure they move freely and spring back to the lock position when released. Lubricate all SAFETY PIVOT points with WD-40 or equal.

10. Run the lift up and down a few times to insure that the locks are engaging uniformly and that the safety release mechanisms are functioning. Re-adjust if necessary.

## STEP 14

(Anchoring The Columns)

### IMPORTANT NOTE:

BendPak lifts are supplied with installation instructions and concrete fasteners meeting the criteria as prescribed by the American National Standard "Automotive Lifts - Safety Requirements for Construction, Testing, and Validation" ANSI/ ALI ALCTV-2011. Lift buyers are responsible for any special regional structural and/ or seismic anchoring requirements specified by any other agencies and/ or codes such as the Uniform Building Code (UBC) and/ or International Building Code (IBC).

1. Before proceeding, DOUBLE CHECK MEASUREMENTS and make certain that the bases of each column are square and aligned with the chalk line. Raise the lift up and down and make sure it operates properly at the locations prescribed by the markings on the floor. (See Fig. 14.1)

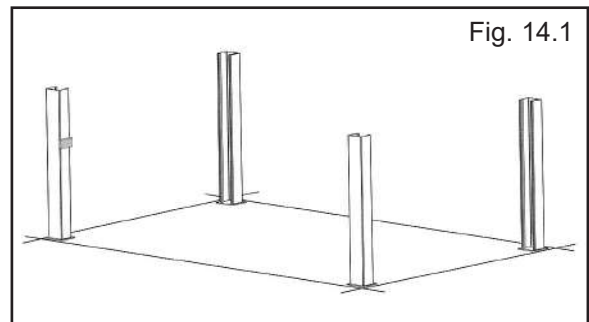

2. Using the BASE PLATE on each column as a guide, drill each anchor hole approximately 5" deep using a rotary hammer drill and 3/4" concrete bit. (See Fig. 14.2)

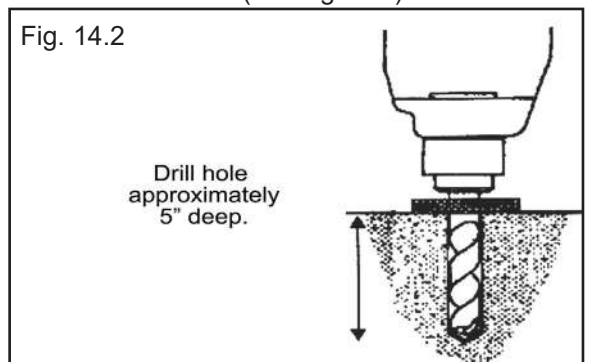

3. After drilling, REMOVE DUST thoroughly from each hole using compressed air and/ or bristle brush. Make certain that the Columns remain aligned with the chalk line.



**ALWAYS WEAR SAFETY GOGGLES.**

4. Assemble the washers and nuts on the anchors then tap into each hole with a sledge until the washer rests against the base plate. Be sure that if shimming is required, enough THREADS ARE LEFT EXPOSED. (See Fig. 14.3)

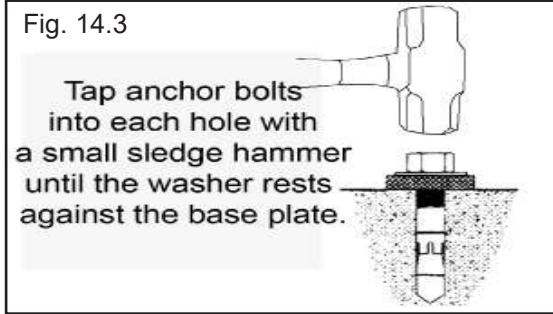

5. If shimming is required, insert the shims as necessary under the base plate so that when the anchor bolts are tightened, the columns will be plumb. (See Fig. 14.4)

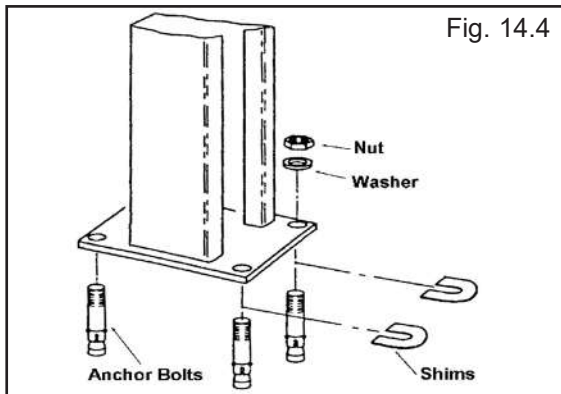

6. After any necessary shims are installed, tighten each anchor nut 3-5 turns past hand tight. **IMPORTANT** - If anchor bolts do not hold when torqued to required amount, concrete must be replaced. Saw cut and remove 24" x 24" square area under each column base then re-pour with reinforced 2500 PSI concrete to a depth of six inches minimum, keying new concrete under existing floor. (See Fig. 14.5)

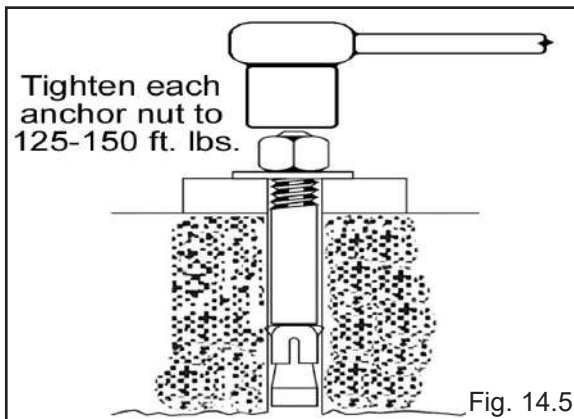

## STEP 15 (Final Assembly)

1. Install the approach ramps on the entry side of the lift. (See Fig. 15.1 & 15.2)

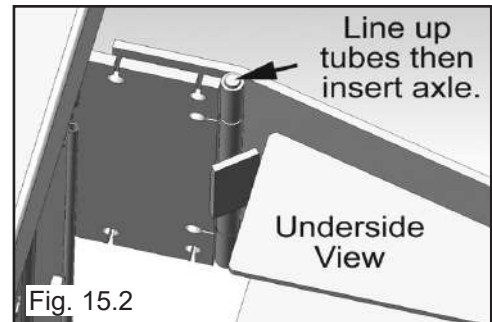
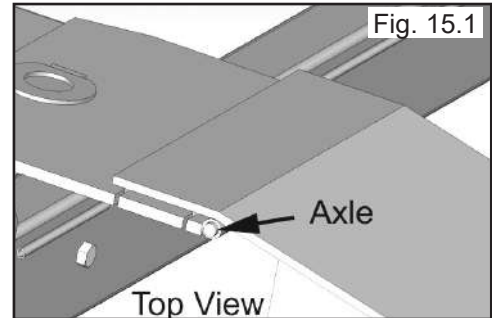

2. Install the front tire stops at the forward end of the lift using the hex bolts, nuts and washers. (See Fig. 15.3)

## STEP 16 (Leveling / Synchronizing)

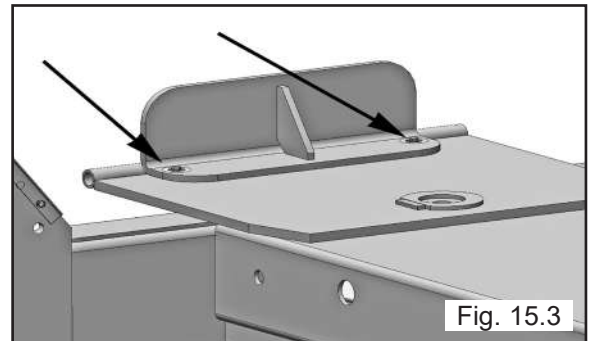

1. Using an engineer's automatic Level (transit), locate the Level, at a convenient location in the shop that allows an unobstructed view of all four corners of the runways.

2. Follow the Level manufacturer's instructions for proper setup of the Level. Be sure it is **ADJUSTED LEVEL** in all directions.

3. Raise the lift approximately 30" - 40" . Then lower lift until all locking latches are engaged in each column and the runways are in full down position on locks.

4. Place a Level target on the right/ front corner of the runway. (See Fig. 16.1)

5. Beginning with “ A ” position, sight the level to the target and mark the number or the graduation on the inch scale of the target that aligns to the cross hairs of the Level, (See Fig. 16.1)

Note:

Use a pencil, marking pen or attach a paper clip onto the target scale at the cross hair reference.

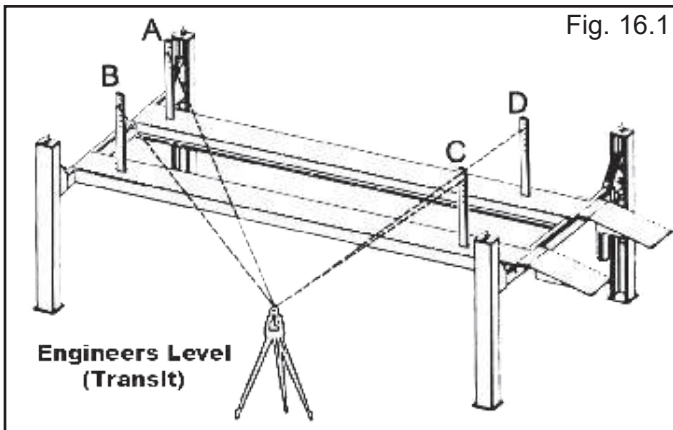

6. Next, move the target and place it at point “ B ” on the runway. (See Fig. 16.1)

7. Rotate the Level and focus on the target scale.

8. Adjust the adjustment nut on the safety ladder bar at the top of the Column at “ B ” until the cross hair of the Level align to reference mark on the target scale. (See Fig. 16.1)

9. Repeat steps locating the target assembly at points “ C ” and “ D ” and adjusting safety ladders at each corresponding Column until the reference mark on the target scale is on the cross hair of the Level. The runways are now level at all four points. (See Fig. 16.1)

10. To complete the leveling procedures, SNUG EACH SAFETY LADDER JAM NUT against the bottom of the Column Top Plate. (See Fig. 16.2)

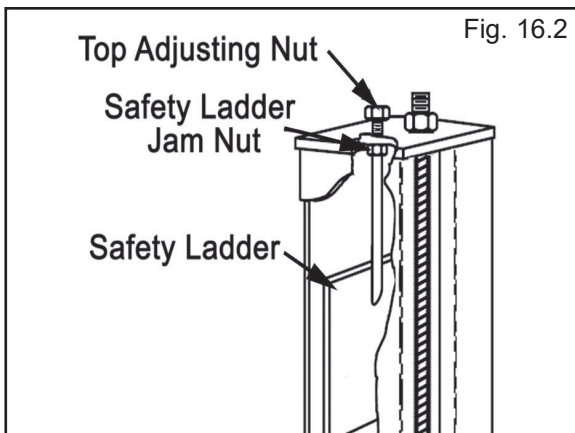

11. Next, load vehicle such as an RV onto the lift.

12. Raise the lift to full height. Listen and watch as the locking latches click in place. SYNCHRONIZE BY ADJUSTING THE CABLES so that all four latches click at the same time. Make necessary adjustments to the cables allowing COMPENSATION FOR STRETCH.



Safety locks may not click in at exactly the same time when vehicles are being raised. They should be close.

Be sure that all four corners have passed the SAME Safety Ladder Bar slot before lowering lift on the safety locks. NEVER lower lift on different safety lock position or damage to the lift may result.

## STEP 17 (Bleeding)

1. Lift must be fully lowered before changing or adding fluid.

2. Raise and lower lift six times. The cylinder is self-bleeding. After bleeding system, fluid level in power unit reservoir may be down. Add more fluid if necessary to raise lift to full height. It is only necessary to add fluid to allow full height raise.

3. To pressure test, run lift to full rise and run motor for approximately 3-seconds after lift stops. This will place pressure on the hydraulic system. Stop and check all fittings and hose connections. Tighten or reseal if required.

## POST-INSTALLATION CHECK-OFF

- Columns properly shimmed and stable
- Anchor Bolts tightened
- Pivot / Sheave Pins properly attached
- Electric power supply confirmed
- Cables adjusted properly
- Safety Locks functioning properly
- Check for hydraulic leaks
- Oil level
- Lubrication of critical components
- Check for overhead obstructions
- All Screws, Bolts, and Pins securely fastened
- Surrounding area clean
- Operation, Maintenance and Safety Manuals on site.
- Perform an Operational Test with a typical vehicle

## OPTIONAL EQUIPMENT INSTALLATION

**Rolling Jack maximum weight capacity for use with**  
**HDS-18E is 9,000 lb (4,082 kg) per unit**  
**HDS-27 or HDS-27X is 13,500 lb (6,124 kg) per unit**  
**HDS-40 or HDS-40X is 20,000 lb (9,072 kg) per unit**

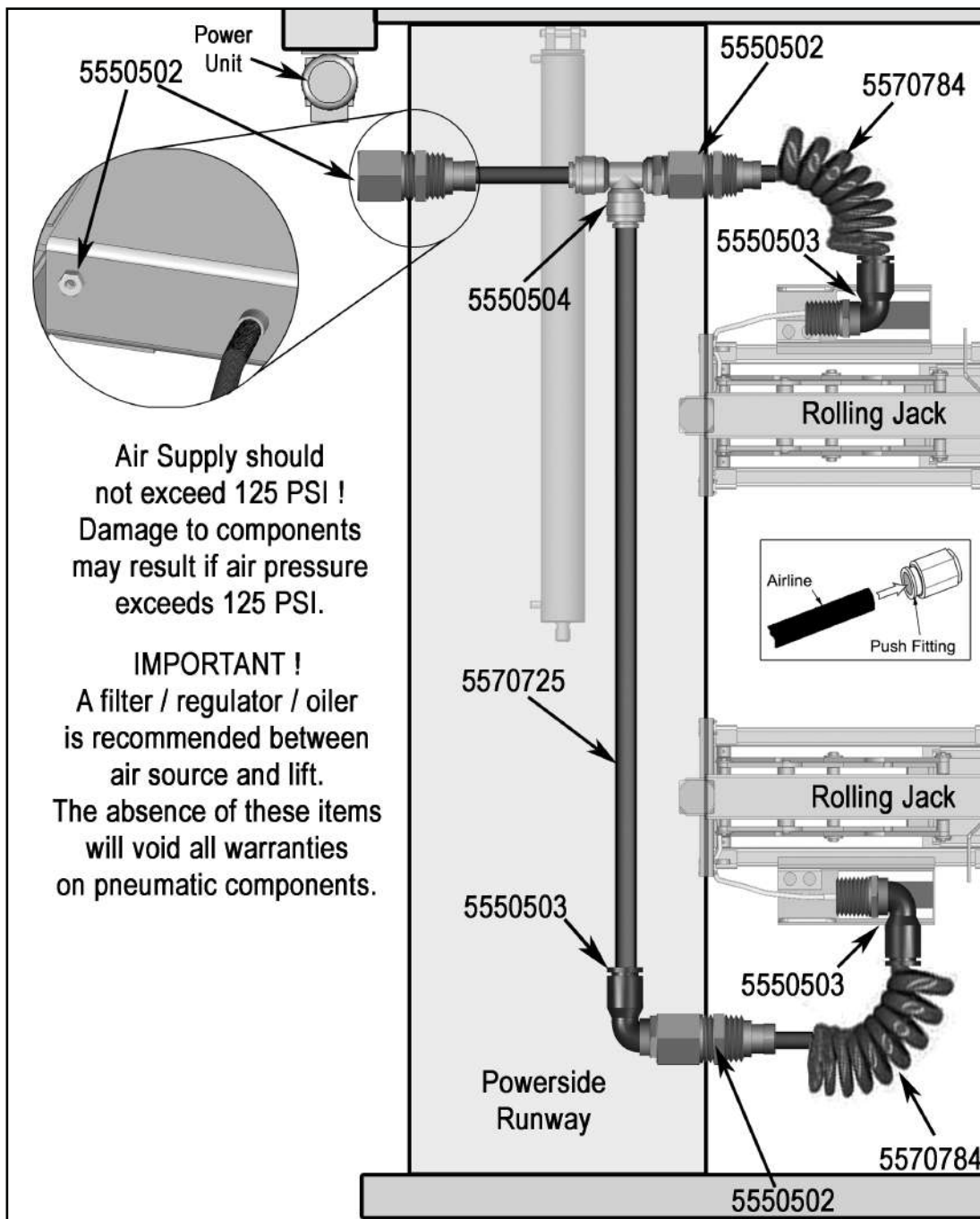

5174010 HD/ HDS-18E; 27; 40 AIR LINE KIT			5174011 HD/ HDS-27X; 40X AIR LINE KIT		
Part #	Description	Qty.	Part #	Description	Qty.
5550502	1/ 4 Bulkhead Female Straight 3/ 8 Tube	3	5550502	1/ 4 Bulkhead Female Straight 3/ 8 Tube	3
5550503	3/ 8 Tube Male Elbow 90° 1/ 4 NPT	3	5550503	3/ 8 Tube Male Elbow 90° 1/ 4 NPT	3
5550504	1/ 4 Male Run Tee 3/ 8 Tube #PST	1	5550504	1/ 4 Male Run Tee 3/ 8 Tube #PST	1
5570784	Ø3/ 8 x 10ft Long Poly Tube Coil Hose	2	5570784	Ø3/ 8 x 10ft Long Poly Tube Coil Hose	2
5570725	Ø10mm Poly Flow Tube	290"	5570725	Ø10mm Poly Flow Tube	340"

## OPTIONAL EQUIPMENT INSTALLATION

# Utility Air-Electric Workstation

Utility Station may be mounted on the vertical column of the lift or on a wall.

**IMPORTANT: Check State or Local codes for any height requirements for the electrical outlets before mounting.**

To mount the Utility Station on a Lift Column, use the Box as a template, mark and drill 11/32" diameter holes. Use 5/16" diameter bolts and lock nuts to secure to the side of the lift.

**IMPORTANT: The hole locations are critical to avoid interference with the carriage slide blocks.**

For Wall mounting, mount in the same fashion use appropriate hardware for either sheet rock or concrete.

**IMPORTANT: All electrical wiring shall comply with all State and Local Codes.**

Connect electrical wiring to single phase, 60Hz 115 volt electrical supply using suitable conduit (not supplied). The duplex receptacle must be connected through the GFCI with the input line to the box connected to a circuit breaker or time delay fuse rated at 20 amps. Both receptacles must be grounded to the box.

Connect main air supply to 1/4" ball valve inlet on the Utility Station (Run 3/8" line from compressor or main air system to Utility Station.)

Install Quick Couplers to the 1/4" male fittings on the box. The air supply between the filter and the lubricator will be non-lubricated, used for tire inflation or blowing off. The air outlet on the left side will be lubricated for air tool use.

### Regulator Instructions

- Regulate pressure by raising the knob, then turning clockwise to increase and counterclockwise to decrease. Push knob down to lock setting.
- Adjust the oil mist using the screwdriver slot located on top of the lubricator.
- To fill the lubricator, first depressurize the air system, remove the slotted screw plug in the body. Replace the screw before repressurizing.

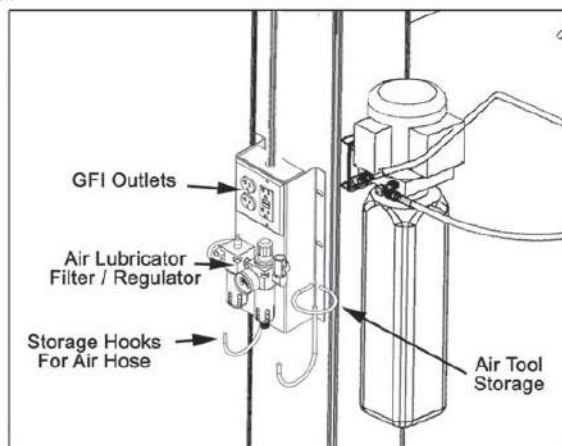
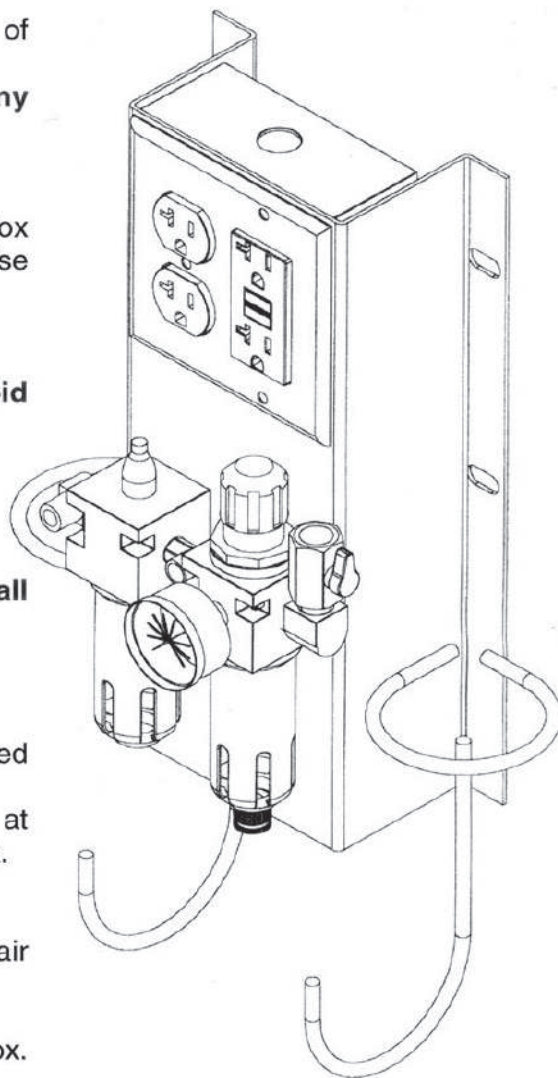

## STEP 19

(Operation Instructions)

### OWNER/EMPLOYER RESPONSIBILITIES

#### The Owner/Employer:

- Shall ensure that lift operators are qualified and that they are trained in the safe use and operation of the lift using the manufacturer's operating instructions; ALI/SM01-1, ALI Lifting it Right safety manual; ALI/ST-90 ALI Safety Tips card; ANSI/ALI ALOIM-2000, American National Standard for Automotive Lifts-Safety Requirements for Operation, Inspection and Maintenance; ALI/WL Series, ALI Uniform Warning Label Decals/Placards; and in the case of frame engaging lifts, ALI/LP-GUIDE, Vehicle Lifting Points/Quick Reference Guide for Frame Engaging Lifts.
- Shall establish procedures to periodically inspect the lift in accordance with the lift manufacturer's instructions or ANSI/ALI ALOIM-2000, American National Standard for Automotive Lifts-Safety Requirements for Operation, Inspection and Maintenance; and The Employer shall ensure that lift inspectors are qualified and that they are adequately trained in the inspection of the lift.
- Shall establish procedures to periodically maintain the lift in accordance with the lift manufacturer's instructions or ANSI/ALI ALOIM-2000, American National Standard for Automotive Lifts-Safety Requirements for Operation, Inspection and Maintenance; and The Employer shall ensure that lift maintenance personnel are qualified and that they are adequately trained in the maintenance of the lift.
- Shall maintain the periodic inspection and maintenance records recommended by the manufacturer or ANSI/ALI ALOIM-2000, American National Standard for Automotive Lifts-Safety Requirements for Operation, Inspection and Maintenance.

- Shall display the lift manufacturer's operating instructions; ALI/SM 93-1, ALI Lifting It Right safety manual; ALI/ST-90 ALI Safety Tips card; ANSI/ALI ALOIM-2000, American National Standard for Automotive Lifts-Safety Requirements for Operation, Inspection and Maintenance; and in the case of frame engaging lifts, ALI/LP-GUIDE, Vehicle Lifting Points/Quick Reference Guide for Frame Engaging Lifts; in a conspicuous location in the lift area convenient to the operator.
- Shall provide necessary lockout/tagout means for energy sources per ANSI Z244.1-1982 (R1993), Safety Requirements for the Lockout/Tagout of Energy Sources, before beginning any lift repairs.
- Shall not modify the lift in any manner without the prior written consent of the manufacturer.

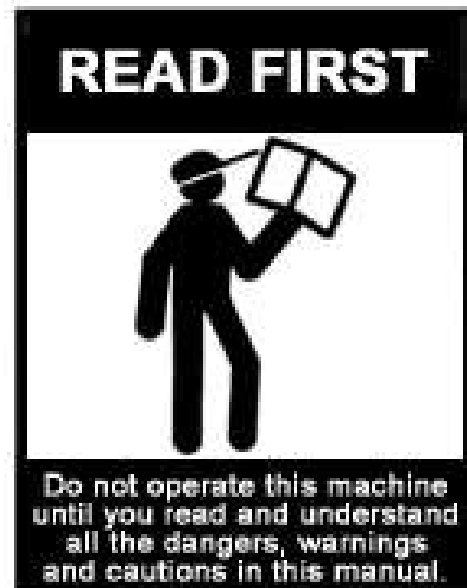

## STEP 20

(Lift Operation Safety)



### WARNING!

TO AVOID PERSONAL INJURY AND/OR PROPERTY DAMAGE, PERMIT ONLY TRAINED PERSONNEL TO OPERATE LIFT. AFTER REVIEWING THESE INSTRUCTIONS, PRACTICE USING LIFT CONTROLS BY RUNNING THE LIFT THROUGH A FEW UNLOADED CYCLES BEFORE LOADING VEHICLE ON LIFT. **NEVER RAISE JUST ONE END, ONE CORNER, OR ONE SIDE OF VEHICLE.**

- **DAILY** inspect your lift. Never operate if it malfunctions or if it has broken or damaged parts. Use only qualified lift service personnel and genuine BendPak parts to make repairs.
- **THOROUGHLY** train all employees in use and care of lift, using manufacturer's instructions and "Lifting It Right" and "Safety Tips" supplied with the lift.
- **NEVER** allow unauthorized or untrained persons to position vehicle or operate lift.
- **PROHIBIT** unauthorized persons from being in shop area while lift is in use.
- **DO NOT** permit anyone on lift or inside vehicle when it is either being raised or lowered.

## LIFT OPERATION SAFETY (CONT'D)

- **ALWAYS** keep area around lift free of tools, debris, grease and oil.
- **NEVER** overload lift. Capacity of lift is shown on nameplate affixed to the lift.
- **DO NOT** stand in front of the vehicle while it is being positioned in lift bay.
- **DO NOT** block open or override self-closing lift controls; they are designed to return to the "Off" or Neutral position when released.
- **ALWAYS** remain clear of lift when raising or lowering vehicles.
- **ALWAYS** use safety stands when removing or installing heavy components.
- **DO NOT** go under raised vehicle if safety locks are not engaged.
- **NEVER LEAVE LIFT IN ELEVATED CONDITION** unless all Safety Locks are engaged.
- **AVOID** excessive rocking of vehicle while on lift.
- **ALWAYS CLEAR AREA** if vehicle is in danger of falling.
- **ALWAYS REMOVE** tool trays, stands, etc. before lowering lift.
- **ALWAYS RELEASE** safety locks before attempting to lower lift.
- **DO NOT** position yourself between a wall and the lift. If the vehicle falls in that direction, you may be severely injured or killed.

### To Raise Lift;

1. Position vehicle tires in the center of each Runway.
2. Set parking brake and use Wheel Chocks to hold vehicle in position.
3. Before raising vehicle, be sure all personnel are clear of the lift and surrounding area. Pay careful attention to overhead clearances.
4. Raise the lift to the desired height by pressing the push button on the power unit.

### NOTE:

ALLOW (2) SECONDS BETWEEN MOTOR STARTS. FAILURE TO COMPLY MAY CAUSE MOTOR BURNOUT.

5. After vehicle is raised to the desired height, lower the lift onto the nearest Safety Lock. Do not allow Cables to become slack. **ALWAYS ENSURE ALL SAFETY LOCKS ARE ENGAGED** before entering work area.



**DANGER!**  
VISUALLY CONFIRM THAT ALL PRIMARY SAFETY LOCKS ARE ENGAGED BEFORE ENTERING WORK AREA. SUSPENSION COMPONENTS USED ON THIS LIFT ARE INTENDED TO RAISE AND LOWER LIFT ONLY AND ARE NOT MEANT TO BE LOAD HOLDING DEVICES. REMAIN CLEAR OF ELEVATED LIFT UNLESS VISUAL CONFIRMATION IS MADE THAT ALL PRIMARY SAFETY LOCKS ARE FULLY ENGAGED AND THE LIFT IS LOWERED ONTO THE SAFETY LOCKS, REFER TO INSTALLATION/ OPERATION MANUAL FOR PROPER SAFETY LOCK PROCEDURES AND/OR FURTHER INSTRUCTION.

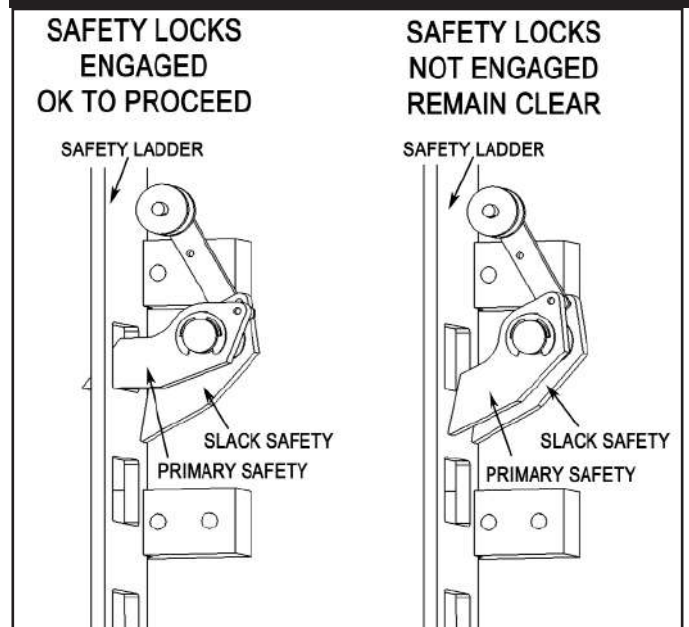

**WARNING!**  
WHEN LOWERING THE LIFT PAY CAREFUL ATTENTION THAT ALL PERSONNEL AND OBJECTS ARE KEPT CLEAR. ALWAYS KEEP A VISUAL LINE OF SIGHT ON THE LIFT AT ALL TIMES. ALWAYS MAKE SURE THAT ALL LOCKS ARE DISENGAGED. IF ONE OF THE LOCKS INADVERTENTLY LOCKS UPON DESCENT THE VEHICLE MAY DISMOUNT CAUSING PERSONAL INJURY OR DEATH.

### To Lower Lift;

1. Before lowering vehicle, be sure all personnel are clear of the lift and surrounding area. Pay careful attention to overhead clearances. Ensure all tools and equipment have been cleared from under the lift.
2. Raise the lift off of the Safety Locks by pressing the push button on the Power Unit. Make sure you raise the lift by at least two inches to allow adequate clearance for the locks to clear.



## LIFT OPERATION SAFETY (CONT'D)

3. Press the push button air safety valve and HOLD.
4. Push the LOWERING HANDLE on the Power Unit until the lift has descended completely.



### CAUTION!

IF YOU ARE NOT COMPLETELY FAMILIAR WITH AUTOMOTIVE LIFT MAINTENANCE PROCEDURES; STOP AND CONTACT THE MANUFACTURER FOR INSTRUCTIONS. TO AVOID PERSONAL INJURY, PERMIT ONLY QUALIFIED PERSONNEL TO PERFORM MAINTENANCE ON THIS EQUIPMENT.

- Every 3 Months: Check anchor bolt torque. Anchors should be torqued to 90 ft/lbs.
- Semi-Annually: Check fluid level of lift power unit and refill if required per lift installation instructions.
- Replace all caution, warning or safety related decals on the lift if unable to read or missing. Reorder labels from BendPak.
- Refer to ANSI/ALI ALOIM booklet for periodic inspection checklist and maintenance log sheet.

### DAILY MAINTENANCE

1. Make a visual inspection of ALL MOVING PARTS and check for excessive signs of wear.
2. Check safety locks to ensure they are in good operating condition.
3. Check cables and sheaves for wear. Replace worn parts as required with genuine BendPak parts.
4. Inspect adapters for damage or excessive wear. Replace as required with genuine BendPak parts.

### WEEKLY MAINTENANCE

1. Lubricate all Sheave and rollers with general purpose oil.
2. Check all Cable connections, bolts and pins to ensure proper mounting.
3. Lubricate Safety Lock pivot points with general purpose oil or WD-40.

### MONTHLY MAINTENANCE

1. Check Safety Locks to ensure they are in good operating condition. Lubricate locking latch shafts. Push release arm several times for oil to penetrate pivot points.
  2. Check equalizer cable tension. Adjust per lift installation instructions.
  3. Check all Cables for excessive signs of wear.
  4. Make a visual inspection of ALL MOVING PARTS and check for excessive signs of wear.
- Always call local service representative if electrical problems develop.
  - Always replace ALL FAULTY PARTS before lift is put back into operation.

# ⚠ WARNING

## WIRE ROPE INSPECTION AND MAINTENANCE

- ◆ Lifting cables should be replaced every three - five years or when visible signs of damage are apparent. **DO NOT USE LIFT WITH DEFECTIVE / WORN CABLES.**
- ◆ Lifting cables should be maintained in a well-lubricated condition at all times. Wire rope is only fully protected when each wire strand is lubricated both internally and externally. Excessive wear will shorten the life of the wire rope. The factory suggested wire rope lubricant that penetrates to the core of the rope and provides long-term lubrication between each individual strand is 90-WT gear oil or ALMASOL® Wire Rope Lubricant. In order to make sure that the inner layers of the rope remain well lubricated, lubrication should be carried out at intervals not exceeding three months during operation.
- ◆ All sheaves and guide rollers in contact with the moving rope should be given regular visual checks for surface wear and lubricated to make sure that they run freely. This operation should be carried out at appropriate intervals generally not exceeding three months during operation. For all sheave axles, the factory recommends standard wheel bearing grease. For all sheaves and/ or guide rollers, the factory recommends 90-WT gear oil or similar heavy lubricant applied by any method including pump / spray dispensing, brush, hand and/ or swabbing.

### HOW OFTEN TO INSPECT

- ◆ Lifting cables should be visually inspected at least once each day when in use, as suggested by American Petroleum Institute (API) RP54 guidelines.
- ◆ Any lifting cables that have met the criteria for removal must be immediately replaced.

### WHEN TO REPLACE LIFTING CABLES DUE TO BROKEN WIRES

- ◆ Lifting cables should be removed from service when you see six randomly distributed broken wires within any one lay length, or three broken wires in one strand within one lay length.

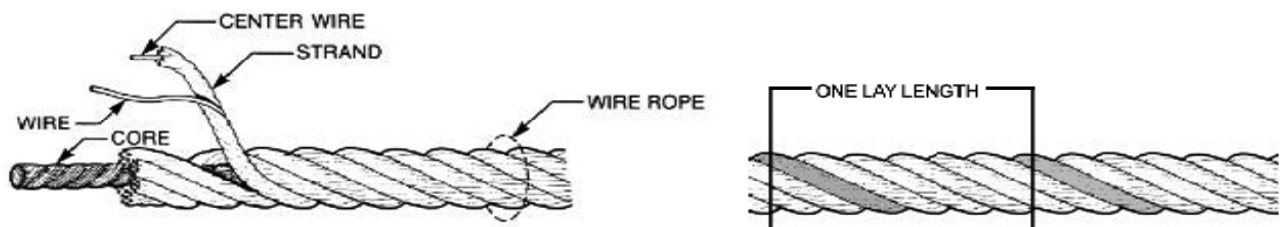

The three basic components of a typical wire rope.

### OTHER REASONS TO REPLACE LIFTING CABLES

- ◆ Corrosion that pits the wires and/ or connectors.
- ◆ Evidence of kinking, crushing, cutting, bird-caging or a popped core.
- ◆ Wear that exceeds 10% of a wire's original diameter.
- ◆ Evidence of heat damage.

### HOW TO FIND BROKEN WIRES

- ◆ The first step is to relax your rope to a stationary position and move the pick-up points off the sheaves. Clean the surface of the rope with a cloth — a wire brush, if necessary — so you can see any breaks.
- ◆ Flex the rope to expose any broken wires hidden in the valleys between the strands.
- ◆ Visually check for any broken wires. One way to check for crown breaks is to run a cloth along the rope to check for possible snags.
- ◆ With an awl, probe between wires and strands and lift any wires that appear loose. Evidence of internal broken wires may require a more extensive rope examination.

## Safe Lift Operation

Automotive and truck lifts are critical to the operation and profitability of your business. The safe use of this and other lifts in your shop is critical in preventing employee injuries and damage to customer's vehicles. By operating lifts safely you can insure that your shop is profitable, productive and safe.

Safe operation of automotive lifts requires that only trained employees should be allowed to use the lift.

### ***TRAINING SHOULD INCLUDE, BUT NOT BE LIMITED TO:***

- ◆ Proper positioning of the vehicle on the runway. (See manufacturers minimize wheel base loading requirements.)
- ◆ Use of the operating controls.
- ◆ Understanding the lift capacity.
- ◆ Proper use of jack stands or other load supporting devices.
- ◆ Proper use, understanding and visual identification of safety lock devices and their operation.
- ◆ Reviewing the safety rules.
- ◆ Proper housekeeping procedures (lift area should be free of grease, oil, tools, equipment, trash, and other debris)
- ◆ A daily inspection of the lift should be completed prior to its use. Safety devices, operating controls, lift arms and other critical parts should be inspected prior to using the lift.
- ◆ All maintenance and repairs of the lift should be completed by following the manufacturer's requirements. Lift repair parts should meet or exceed OEM specifications. Repairs should only be completed by a qualified lift technician.
- ◆ The vehicle manufacturer's recommendations should be used for spotting and lifting the vehicle.

### ***LIFT OPERATION SAFETY***

- ◆ It is important that you know the load limit. Be careful that you do not overload the lift . If you are unsure what the load limit is, check the data plate found on one of the lift columns or contact the manufacturer.
- ◆ The center of gravity should be followed closely to what the manufacturer recommends.
- ◆ Always make sure you have proper overhead clearance. Additionally, check that attachments, ( vehicle signs, campers antennas, etc. ) are not in the way.
- ◆ Be sure that prior to the vehicle being raised, the doors, trunk, and hood are closed securely
- ◆ Prior to being raised, make sure there is no one standing closer than six feet from the lift
- ◆ After positioning the vehicle on the lift runways, set the emergency brake, make sure the ignition is off, the doors are closed, overhead obstructions are cleared, and the transmission is in neutral.
- ◆ Double check that the automatic chock devices are in position and then when the lift is raised, observe the chocks
- ◆ Put pads or adaptors in the right position under the contact points that have been recommended
- ◆ The lift should be raised just until the vehicle's wheels are about one foot off the ground. If contact with the vehicle is uneven or it appears that the vehicle is not sitting secure, carefully lower the lift and readjust.
- ◆ Always consider potential problems that might cause a vehicle to slip, i.e., heavy cargo, undercoating, etc.



- ◆ Pay attention when walking under a vehicle that is up on the hydraulic lift
- ◆ **DO NOT** Leave the controls while the lift is still in motion.
- ◆ **DO NOT** stand directly in front of the vehicle or in the bay when vehicle is being loaded or driven into position.
- ◆ **DO NOT** Go near vehicle or attempt to work on the vehicle when being raised or lowered. **REMAIN CLEAR** of lift when raising or lowering vehicle.
- ◆ **DO NOT** rock the vehicle while on the lift or remove any heavy component from vehicle that may cause excessive weight shift.
- ◆ **DO NOT** lower the vehicle until people, materials, and tools are clear
- ◆ **ALWAYS INSURE** that the safeties are engaged before any attempt is made to work on or near vehicle.
- ◆ Some vehicle maintenance and repair activities may cause the vehicle to shift. Follow the manufacturer's guidelines when performing these operations. The use of jack stands or alternate lift points may be required when completing some repairs.
- ◆ **READ AND UNDERSTAND** all safety warning procedures before operating lift.
- ◆ **KEEP HANDS AND FEET CLEAR.** Remove hands and feet from any moving parts. Keep feet clear of lift when lowering. Avoid pinch points.
- ◆ **ONLY TRAINED OPERATORS** should operate this lift. All non-trained personnel should be kept away from work area. Never let non-trained personnel come in contact with, or operate lift.
- ◆ **USE LIFT CORRECTLY.** Use lift in the proper manner. Never use lifting adapters other than what is approved by the manufacturer.
- ◆ **DO NOT** override self-closing lift controls.
- ◆ **CLEAR AREA** if vehicle is on danger of falling.
- ◆ **STAY ALERT.** Watch what you are doing. Use common sense. Be aware.
- ◆ **CHECK FOR DAMAGED PARTS.** Check for alignment of moving parts, breakage of parts or any condition that may affect its operation. Do not use lift if any component is broken or damaged.
- ◆ **NEVER** remove safety related components from the lift. Do not use lift if safety related components are damaged or missing.
- ◆ When the lift is being lowered, make sure everyone is standing at least six feet away.
- ◆ Be sure there are no jacks, tools, equipment, left under the lift before lowering.
- ◆ Always lower the vehicle down slowly and smoothly.

# LIFT WILL NOT RAISE

## **POSSIBLE CAUSE**

1. Air in oil, (1,2,8,13)
2. Cylinder binding, (9)
3. Cylinder leaks internally, (9)
4. Motor run backward under pressure, (11)
5. Lowering valve leaks, (3,4,6,10,11)
6. Motor runs backwards, (7,14,11)
7. Pump damaged, (10,11)
8. Pump won't prime, (1,8,13,14,3,12,10,11)
9. Relief valve leaks, (10,11)
10. Voltage to motor incorrect, (7,14,11)

## **REMEDY**

1. Check for proper oil level
2. Bleed cylinders
3. Flush- Release valve to get rid of possible contamination.
4. Dirty oil
5. Tighten all fasteners
6. Check for free movement of release
7. Check motor is wired correctly.
8. Oil seal damaged or cocked
9. See Installation Manual
10. Replace with new part
11. Return unit for repair
12. Check pump-mounting bolts
13. Inlet screen clogged
14. Check wall outlet voltages and wiring

## **INSTRUCTION**

The oil level should be up to the bleed screw in the reservoir with the lift all the way down.

See Installation Manual

Hold release handle down and start unit allowing it to run for 15 seconds.

Replace oil with clean Dexron ATF

Tighten fasteners to recommended torques.

If handle does not move freely, replace bracket or handle assembly.

Compare wiring of motor to electrical diagram on drawing.

Replace oil seal around pump shaft.

Consult Lift Manufacturer

Replace with new part

Return unit for repair

Bolts should be 15 to 18 ft. lbs.

Clean inlet screen or replace

Make sure unit and wall outlet are wired properly.

## MOTOR WILL NOT RUN

### **POSSIBLE CAUSE**

1. Fuse blown, (5,2,1,3,4)
2. Limit switch burned out, (1,2,3,4)
3. Microswitch burned out, (1,2,3,4)
4. Motor burned out, (1,2,3,4,6)
5. Voltage to motor incorrect, (2,1,8)

### **REMEDY**

1. Check for correct voltage
2. Check motor is wired correctly
3. Don't use extension cords
4. Replace with new part
5. Reset circuit breaker/ fuse
6. Return unit for repair
7. See Installation Manual
8. Check wall outlet voltage and wiring

### **INSTRUCTION**

- Compare supply voltage with voltage on motor name tag. Check that the wire is sized correctly. N.E.C. table 310-12 requires AWG 10 for 25 Amps.
- Compare wiring of motor to electrical diagram on drawing.
- According to N.E.C. : “ The size of the conductors...should be such that the voltage drop would not exceed 3% to the farthest outlet for power...” Do not run motor at 115 VAC – damage to the motor will occur.
- Replace with new part
- Reset circuit breaker/ fuse
- Return unit for repair
- See Installation Manual
- Make sure unit and wall outlet is wired properly. Motor must run at 208/ 230 VAC.

## LIFT LOWERS SLOWLY OR NOT AT ALL

### **POSSIBLE CAUSE**

1. Cylinders binding, (1)
2. Release valve clogged, (5,4,2,3)
3. Pressure fitting too long, (6)

### **REMEDY**

1. See Installation Manual
2. Replace with new part
3. Return for repair
4. Check oil
5. Clean release valve
6. Replace fitting with short thread lead

### **INSTRUCTION**

- Consult Lift Manufacturer
- Replace with new part
- Return for repair
- Use clean 10-WT hydraulic oil or Dexron automatic transmission fluid only. If ATF is contaminated, replace with clean ATF and clean entire system.
- Wash release valve in solvent and blow out with air.
- Replace fitting with short thread lead

## WILL NOT RAISE LOADED LIFT

### **POSSIBLE CAUSE**

1. Air in oil, (1,2,3,4)
2. Cylinder binding, (5)
3. Cylinder leaks internally, (5)
4. Lift overloaded, (6,5)
5. Lowering valve leaks, (7,8,1,5,9)
6. Motor runs backwards, (10,12,9)
7. Pump damaged, (5,9)
8. Pump won't prime, (1,2,3,4,5,11,9)
9. Relief valve leaks, (8,5,9)
10. Voltage to motor incorrect, (10,12,5)

### **REMEDY**

1. Check oil level
2. Check/ Tighten inlet tubes
3. Oil seal damaged or cocked
4. Bleed cylinders
5. See Installation Manual
6. Check vehicle weight
7. Flush release valve
8. Replace with new part
9. Return unit for repair
10. Check motor is wired correctly
11. Inlet screen clogged
12. Check wall outlet voltage and wiring

### **INSTRUCTION**

- The oil level should be up to the bleed screw in the reservoir with the lift all the way down.]
- Replace inlet hose assembly.
  - Replace oil seal and install
  - See Installation Manual
  - Consult Lift Manufacturer
  - Compare weight of vehicle to weight limit of the lift.
  - Hold release handle down and start unit allowing it to run for 15 seconds.
  - Replace with new part
  - Return unit for repair
  - Compare wiring of motor to electrical diagram on unit drawing
  - Clean inlet screen or replace.
  - Make sure unit and wall outlet is wired properly.

## **IMPORTANT**

If vehicle becomes stranded in the air, follow all operation instructions as shown on pages 31, 32, and 39. If after observing that all mechanical locks are released and the lift still fails move following all standard operating procedures, immediately stop using the lift and contact factory or factory approved service center for further instructions.

# LIFT WILL NOT STAY UP

## **POSSIBLE CAUSE**

1. Air in oil, (1,2,3)
2. Check valve leaks, (6)
3. Cylinders leak internally, (7)
4. Lowering valve leaks, (4,5,1,7,6)
5. Leaking fittings, (8)

## **REMEDY**

- |   |  |
|---|--|
| 1. Check oil level . . . . .                          | <b>INSTRUCTION</b><br>The oil level should be up to the bleed screw in the reservoir with the lift all the way down. |
| 2. Oil seal damaged and cocked . . . . .              | Replace oil seal around pump shaft.  |
| 3. Bleed cylinder . . . . .                           | Refer to Installation Manual.  |
| 4. Flush release valve . . . . .                      | Hold release handle down and start unit allowing it to run for 15 seconds.   |
| 5. Replace with new valve . . . . .                   | Replace with new valve.  |
| 6. Return unit for repair . . . . .                   | Return unit for repair.  |
| 7. See Installation Manual . . . . .                  | Consult Lift Manufacturer.   |
| 8. Check complete hydraulic system for leaks. . . . . | Tighten all hydraulics fittings and inspects all hoses.  |



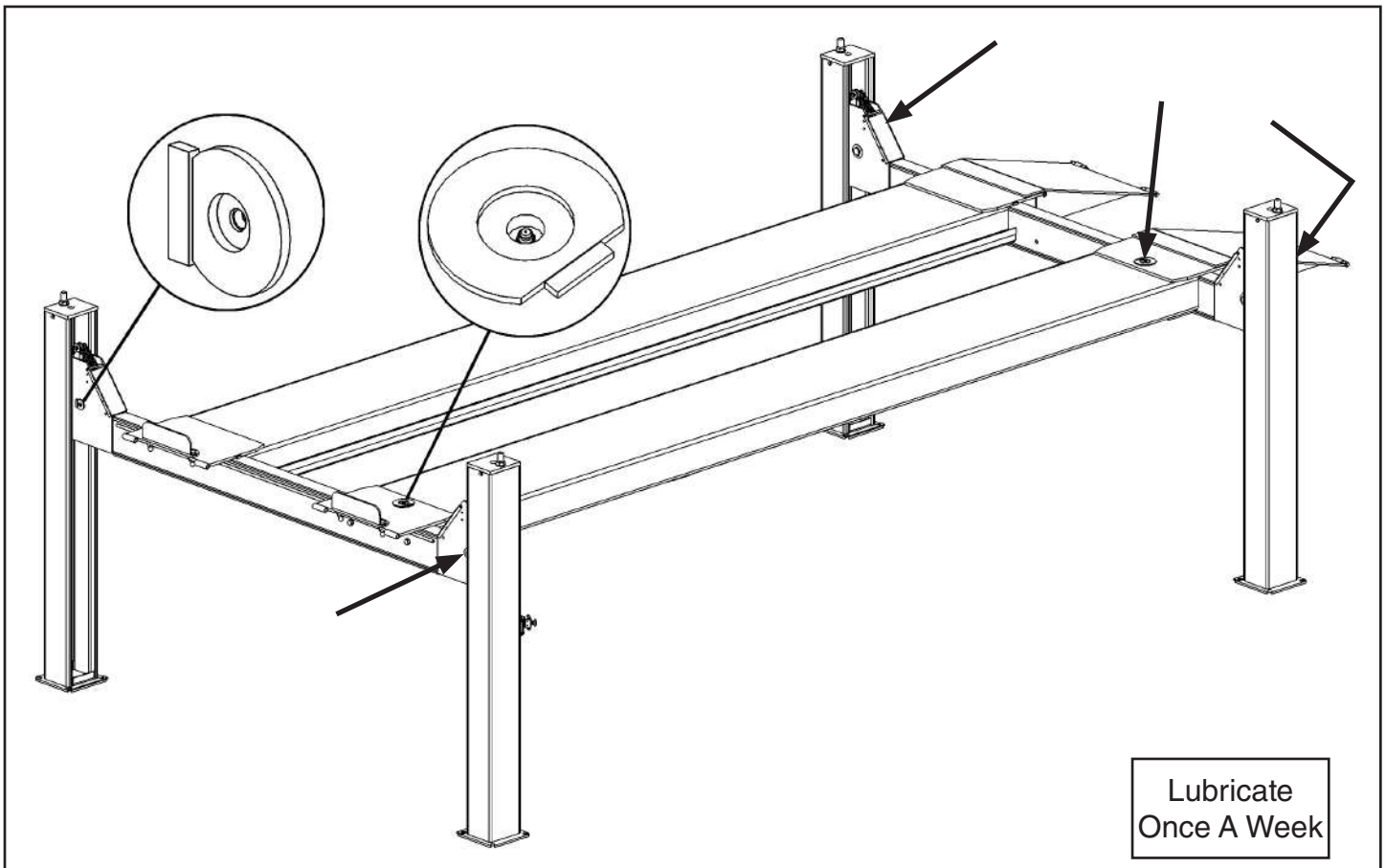

## Grease Port / Lubrication Locations



## Torque Recommendations

VALUES ARE STATED IN FOOT POUNDS (ft-lb)

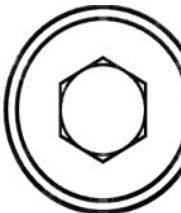
					
		SAE 0-1-2 CLASS 4.8	SAE Grade 5 CLASS 8.8	SAE Grade 8 CLASS 10.9	SOCKET HEAD CAP SCREW CLASS 12.9
<b>Bolt Size (SAE)</b>	<b>Bolt Size (Metric)</b>				
1/4-20	M6 x 1.0	6	10	14	13
5/16-18	M8 x 1.25	12	19	29	31.4
3/8-16	M10 x 1.50	20	33	47	62
7/16-14		32	54	78	
1/2-13	M12 x 1.75	47	78	119	108
9/16-12	M14 x 2.00	69	114	169	173
5/8-11	M16 x 2.00	96	154	230	269
3/4-10	M18 x 2.50	155	257	380	372
7/8-9	M22 x 2.50	206	382	600	716
3/4 Anchor Bolts		75 MIN 110 MAX			



**D**

<b>⚠ DANGER</b>
<b>THE MAXIMUM LIFTING CAPACITY FOR THIS LIFT IS DESCRIBED BELOW</b>
Maximum Lifting Capacity
Max. Lifting Cap. / Front of Lift Center
Max. Lifting Cap. / Rear of Lift Center
Exceeding the weight capacity of this lift can damage lift and/or property and may cause personal harm, injury or death to operators and/or bystanders. All vehicles MUST be positioned on lift with CENTER OF GRAVITY midway between adapters and/or centered on runways. Damage to lift due to overloading or misuse IS NOT covered under warranty.
<b>LA CAPACITÉ DE LEVAGE MAXIMUM POUR CE LEVAGE EST DÉCRIT CI-DESSOUS</b>
Capacité de Levage Maximale
Max. Capuchon De Levage. / Avant du centre de relèvement
Max. Capuchon De Levage. / Arrière du centre de levage
Le dépassement de la capacité de poids de cet élévateur peut endommager l'ascenseur et / ou les biens et peut causer des dommages corporels, des blessures voire la mort aux opérateurs et / ou aux passants. Tous les véhicules DOIVENT être placés sur l'élevateur avec le CENTRE DE GRAVITÉ à mi-chemin entre les adaptateurs et / ou au centre des pistes. Dommages à soulever dus à la surcharge ou une mauvaise utilisation N'EST PAS couverte par la garantie.

PTM 348002

**E**

<b>⚠ ATTENTION ⚠</b>
<b>MAXIMUM LIFTING CAPACITY CAPACITÉ DE LEVAGE MAXIMUM</b>
<b>Lbs.</b>
<b>Kg.</b>

PAJ 600668

**F**

<b>BP BendPak</b> PROVIDING AUTOMOTIVE SERVICE SOLUTIONS	Santa Paula, CA USA WWW.BENDPAK.COM PH 5905940
LIFT TYPE: SURFACE MOUNT	MFQ. BPK SEE DATA PLATE FOR PRODUCT DETAILS
POWER: ELECTRIC/HYDRAULIC	INSTALLATION - SEE OWNERS GUIDE OR CONTACT FACTORY
SAFETY INSTRUCTIONS: IF ATTACHMENTS, ACCESSORIES OR CONFIGURATION MODIFYING COMPONENTS THAT ARE LOCATED IN THE LOAD PATH, AFFECT OPERATION OF THE LIFT, AFFECT THE LIFT ELECTRICAL LISTING OR AFFECT INTENDED VEHICLE ACCOMMODATION ARE USED ON THIS LIFT AND, IF THEY ARE NOT CERTIFIED FOR USE ON THIS LIFT, THEN THE CERTIFICATION OF THIS LIFT SHALL BECOME NULL AND VOID. CONTACT THE PARTICIPANT FOR INFORMATION PERTAINING TO CERTIFIED ATTACHMENTS, ACCESSORIES OR CONFIGURATION MODIFYING COMPONENTS.	
BENDPAK LIFTS ARE SUPPLIED WITH CONCRETE FASTENERS MEETING THE CRITERIA AS PRESCRIBED BY ASTM E488 - 96(2003). LIFT BUYERS ARE RESPONSIBLE FOR ANY SPECIAL REGIONAL STRUCTURAL AND/OR SEISMIC ANCHORING REQUIREMENTS SPECIFIED BY ANY OTHER AGENCIES AND/OR CODES SUCH AS THE UNIFORM BUILDING CODE (UBC) AND/OR INTERNATIONAL BUILDING CODE (IBC).	
THE MANUFACTURE, USE, SALE OR IMPORT OF THIS PRODUCT MAY BE SUBJECT TO ONE OR MORE UNITED STATES PATENTS, OR PENDING APPLICATIONS, OWNED BY BENDPAK, INC. DO NOT REMOVE      ENGINEERED BY BENDPAK INC. USA      MADE IN CHINA	

**G**

<b>NOTICE</b>	If attachments, accessories, or configuration modifying components used on this lift are located in the load path and affect operation of the lift, affect the lift electrical listing, or affect intended vehicle accommodation; and if they are not certified for use on this lift, then the certification of this lift shall become null and void. Contact the participant for information pertaining to certified attachments, accessories, or configuration modifying components.
www.autolift.org	©2011 by ALI, Inc.      ALI / WLSIA01

**H**

<b>CERTIFIED AUTOMOTIVE LIFT</b>	
 ALI CERTIFIED To the provisions of ANS/ALI ALCTV-2011 SAFETY REQUIREMENTS FOR CONSTRUCTION, TESTING AND VALIDATION	
Automotive Lift Institute, Inc.   Corland, NY 13045	
MET LISTED Conforms to ANSIUL 201 SAFETY STANDARD FOR GARAGE EQUIPMENT	 MET LISTED MET Laboratories, Inc. BALTIMORE, MD 21205
Certification Label Serial Number	
 AL00617000J	

**I**

<b>BP BendPak</b> Santa Paula, CA USA www.bendpak.com	
MODEL NUMBER	
DESCRIPTION	
LIFT CAPACITY	DATE OF MFG.
ROLLING JACK MAX CAP.	MAX PSI / BAR
VOLTAGE	SERIAL NUMBER
<input type="checkbox"/> 110-240V, 50-60 Hz, 1 Ph <input type="checkbox"/> 208-240V, 50-60 Hz, 1 Ph <input type="checkbox"/> 380-415V, 50-60 Hz, 3 Ph <input type="checkbox"/> 208-440V, 50-60 Hz, 3 Ph	UPC
<b>DANGER!</b> Disconnect Power Before Servicing	WARRANTY VOID IF DATA PLATE IS REMOVED    PH 5905953

**J**

<b>BP BendPak</b> Santa Paula, CA USA www.bendpak.com	
MODEL NUMBER	
DESCRIPTION	
LIFT CAPACITY	DATE OF MFG.
ROLLING JACK MAX CAP.	MAX PSI / BAR
VOLTAGE	SERIAL NUMBER
<input type="checkbox"/> 110-240V, 50-60 Hz, 1 Ph <input type="checkbox"/> 208-240V, 50-60 Hz, 1 Ph <input type="checkbox"/> 380-415V, 50-60 Hz, 3 Ph <input type="checkbox"/> 208-440V, 50-60 Hz, 3 Ph	UPC
<b>DANGER!</b> Disconnect Power Before Servicing	WARRANTY VOID IF DATA PLATE IS REMOVED    PH 5905952

**A**  
Top of  
Each Post



Back of  
Powerside  
Post

Side of  
Powerside  
Post

Front of  
Powerside  
Post

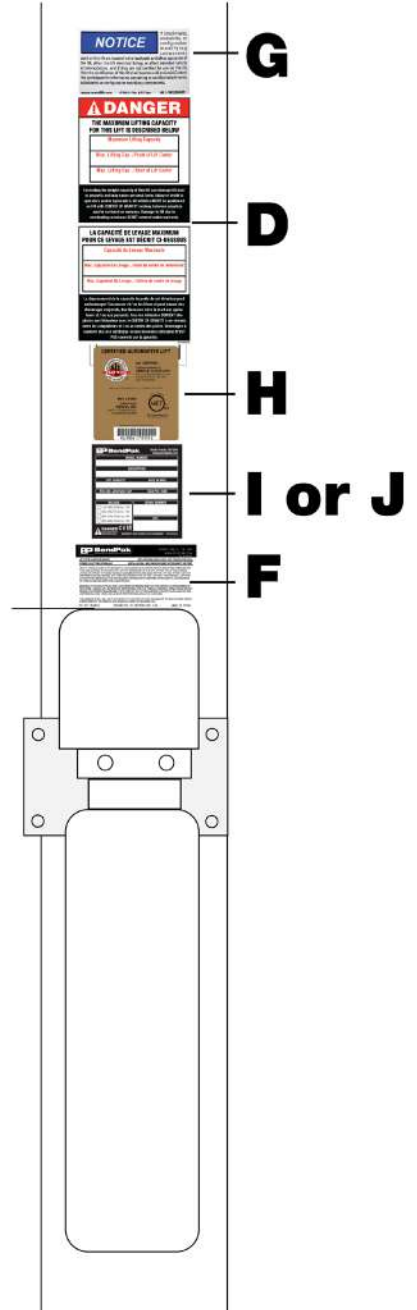
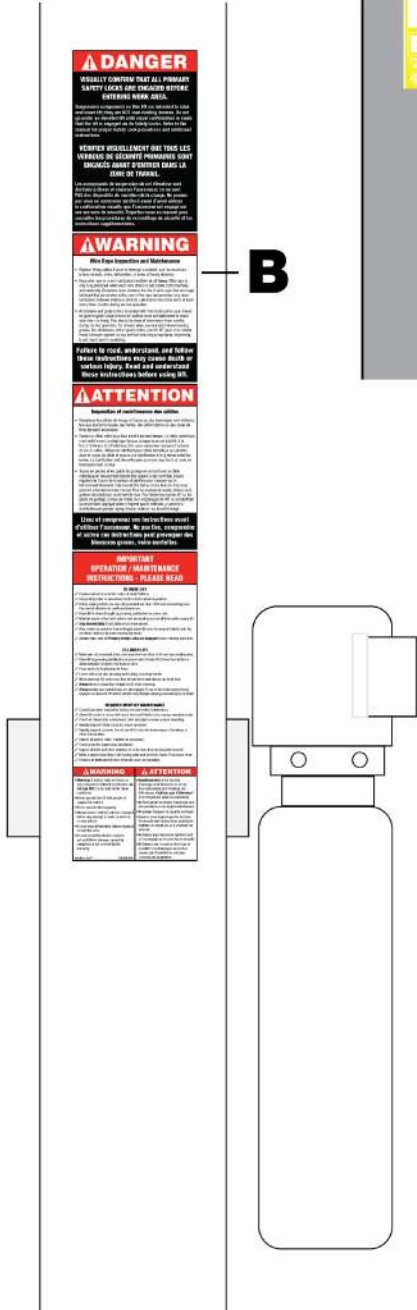
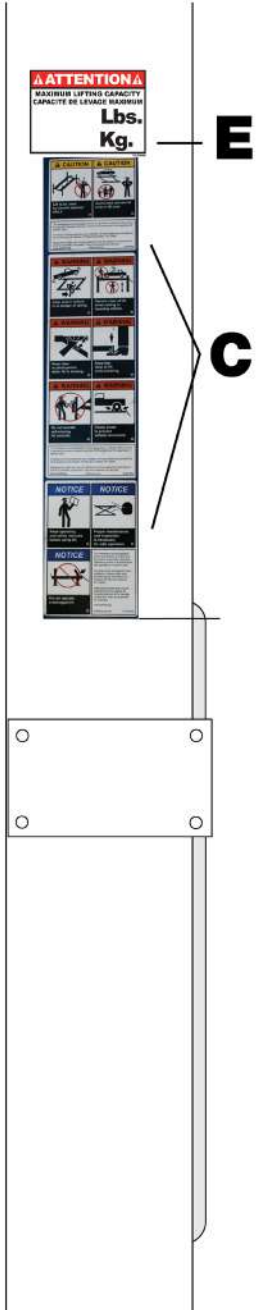

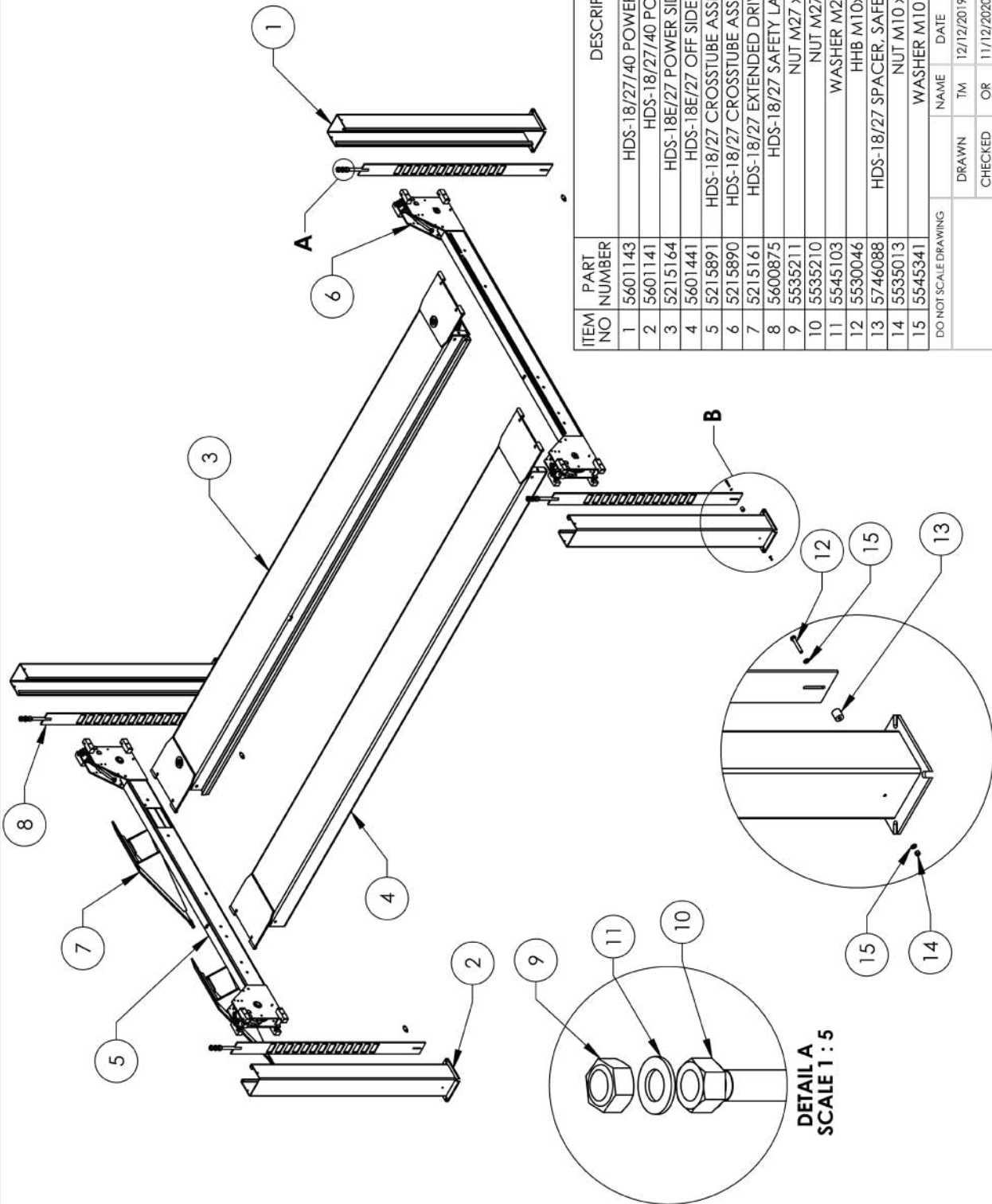

ITEM NO	PART NUMBER	DESCRIPTION	QTY	REV
1	5601143	HDS-18/27/40 POWER POST WELDMENT	1	B
2	5601141	HDS-18/27/40 POST WELDMENT	3	B
3	5215164	HDS-18E/27 POWER SIDE RAMP ASSEMBLY	1	Y
4	5601441	HDS-18E/27 OFF SIDE RAMP WELDMENT	1	A
5	5215891	HDS-18/27 CROSSTUBE ASSEMBLY, LARGE WINDOW	1	B
6	5215890	HDS-18/27 CROSSTUBE ASSEMBLY, SMALL WINDOW	1	B
7	5215161	HDS-18/27 EXTENDED DRIVE UP RAMP ASSEMBLY	2	J
8	5600875	HDS-18/27 SAFETY LADDER WELDMENT	4	C
9	5535211	NUT M27 x 3.0 NL	4	--
10	5535210	NUT M27 x 3.0	4	--
11	5545103	WASHER M27 x 50mm	4	--
12	5530046	HHB M10x1.5x65	4	--
13	5746088	HDS-18/27 SPACER, SAFETY LADDER, 31mm LG	4	B
14	5535013	NUT M10 x 1.5 NL	4	--
15	5545341	WASHER M10 x Ø20 FLAT	8	--

DO NOT SCALE DRAWING

NAME	DATE
DRAWN TM	12/12/2019
CHECKED OR	11/12/2020

THIRD ANGLE PROJECTION

BP **BendPak**  
1645 LEMONWOOD DR.  
SANTA PAULA, CA 93060

TITLE: HDS-18E LIFT SUPERSTRUCTURE

SIZE DWG. NO. 5245088

REV C

SCALE: 1:55

SHEET 1 OF 1

PROPRIETARY AND CONFIDENTIAL  
THE INFORMATION CONTAINED IN THIS DRAWING IS THE PROPERTY OF BENDPAK INC. ANY REPRODUCTION IN PART OR AS A WHOLE WITHOUT THE WRITTEN PERMISSION OF BENDPAK INC. IS PROHIBITED.

SMILEY FACE ICON

DIMENSIONS ARE IN MM

NEXT ASSEMBLY  
5260604

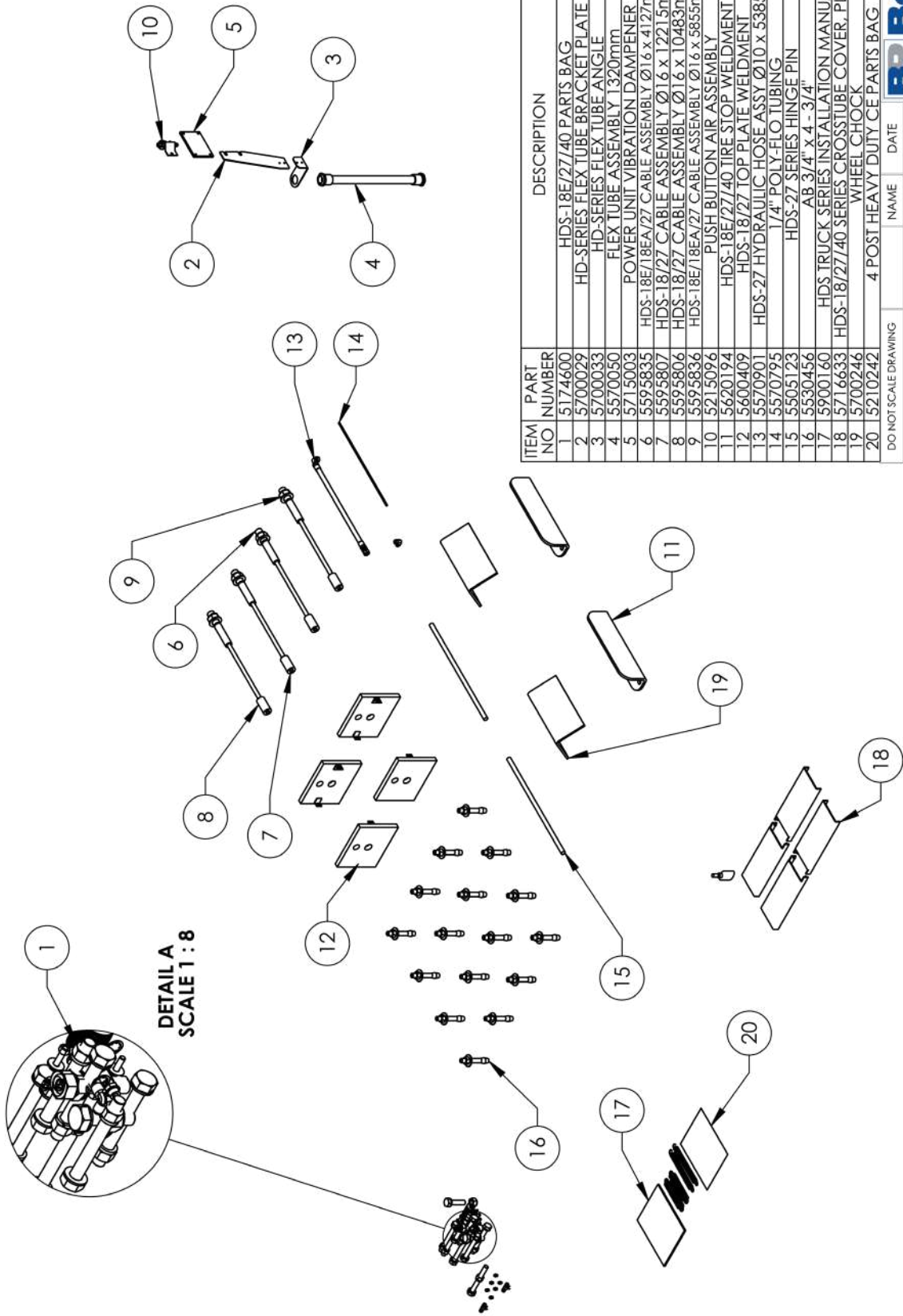

DETAIL A  
SCALE 1 : 8

ITEM NO	PART NUMBER	DESCRIPTION	QTY.	REV
1	5174600	HDS-18E/27/40 PARTS BAG	1	G
2	5700029	HD-SERIES FLEX TUBE BRACKET PLATE	1	F
3	5700033	HD-SERIES FLEX TUBE ANGLE	1	E
4	5570050	FLEX TUBE ASSEMBLY 1320mm	1	B
5	5715003	POWER UNIT VIBRATION DAMPENER	1	B
6	5595835	HDS-18E/18EA/27 CABLE ASSEMBLY Ø16 x 4127mm ST	1	E
7	5595807	HDS-18/27 CABLE ASSEMBLY Ø16 x 1221.5mm ST	1	J
8	5595806	HDS-18/27 CABLE ASSEMBLY Ø16 x 10483mm ST	1	H
9	5595836	HDS-18E/18EA/27 CABLE ASSEMBLY Ø16 x 5855mm ST	1	E
10	5215096	PUSH BUTTON AIR ASSEMBLY	1	G
11	5620194	HDS-18E/27/40 TIRE STOP WELDMENT	2	C
12	5600409	HDS-18/27 TOP PLATE WELDMENT	4	D
13	5570901	HDS-27 HYDRAULIC HOSE ASSY Ø10 x 5385mm	1	C
14	5570795	1/4" POLY-FLO TUBING	24000mm*	-
15	5505123	HDS-27 SERIES HINGE PIN	2	B
16	5530456	AB 3/4" x 4 - 3/4	16	-
17	5900160	HDS TRUCK SERIES INSTALLATION MANUAL	1	-
18	5716633	HDS-18/27/40 SERIES CROSSTUBE COVER, PLASTIC	4	C
19	5700246	WHEEL CHOCK	2	B
20	5210242	4 POST HEAVY DUTY CE PARTS BAG	1	A

DO NOT SCALE DRAWING

NAME	DATE
DRAWN TM	05/08/2013
CHECKED OR	4/24/2020

THIRD ANGLE PROJECTION

TITLE: HDS-18E/27 PARTS BOX

BP BendPak®  
1645 LEMONWOOD DR.  
SANTA PAULA, CA 93060

SIZE DWG. NO. 5250172

REV K

SCALE: 1:25

SHEET 1 OF 1

PROPRIETARY AND CONFIDENTIAL  
THE INFORMATION CONTAINED HEREIN IS THE SOLE PROPERTY OF BENDPAK INC. ANY REPRODUCTION IN PART OR AS A WHOLE WITHOUT THE WRITTEN PERMISSION OF BENDPAK INC. IS PROHIBITED.

NEXT ASSEMBLY
5260604
5260606

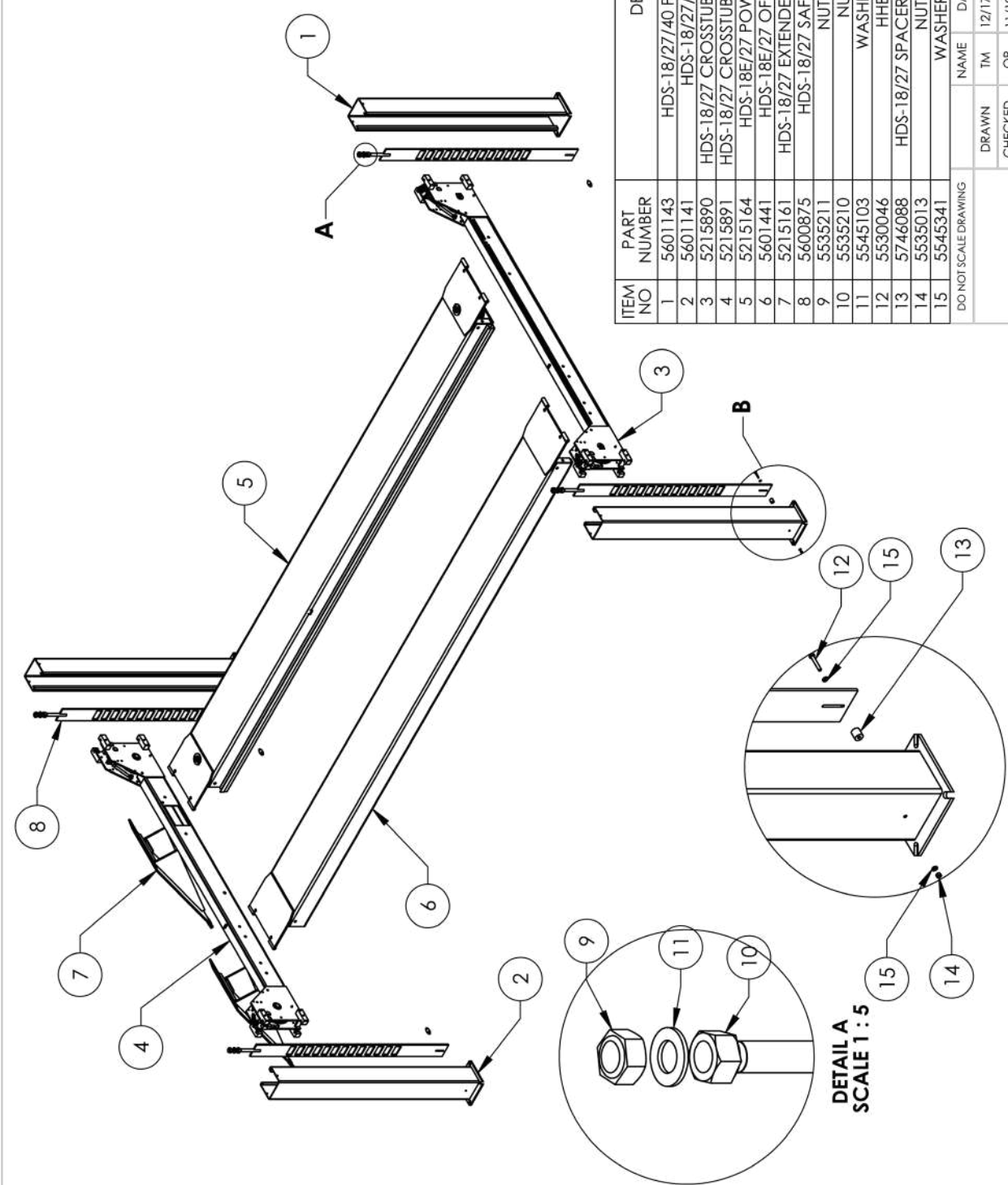

ITEM NO	PART NUMBER	DESCRIPTION	QTY	REV
1	5601143	HDS-18/27/40 POWER POST WELDMENT	1	B
2	5601141	HDS-18/27/40 POST WELDMENT	3	B
3	5215890	HDS-18/27 CROSS-TUBE ASSEMBLY, SMALL WINDOW	1	B
4	5215891	HDS-18/27 CROSS-TUBE ASSEMBLY, LARGE WINDOW	1	B
5	5215164	HDS-18E/27 POWER SIDE RAMP ASSEMBLY	1	Y
6	5601441	HDS-18E/27 OFF SIDE RAMP WELDMENT	1	A
7	5215161	HDS-18/27 EXTENDED DRIVE UP RAMP ASSEMBLY	2	J
8	5600875	HDS-18/27 SAFETY LADDER WELDMENT	4	C
9	5535211	NUT M27 x 3.0 NL	4	-
10	5535210	NUT M27 x 3.0	4	-
11	5545103	WASHER M27 x 50mm	4	-
12	5530046	HHB M10x1.5x65	4	-
13	5746088	HDS-18/27 SPACER, SAFETY LADDER, 31mm LG	4	B
14	5535013	NUT M10 x 1.5 NL	4	-
15	5545341	WASHER M10 x Ø20 FLAT	4	-

DO NOT SCALE DRAWING

NAME	DATE
DRAWN	12/17/2019
CHECKED	OR 11/12/2020

THIRD ANGLE PROJECTION

BP BendPak.  
1645 LEMONWOOD DR.  
SANTA PAULA, CA 93060

TITLE: HDS-27 LIFT SUPERSTRUCTURE

SIZE DWG. NO. A 5245090

REV C

SCALE: 1:55

SHEET 1 OF 1

PROPRIETARY AND CONFIDENTIAL  
THE INFORMATION CONTAINED IN THIS DRAWING IS THE PROPERTY OF BENDPAK INC. ANY REPRODUCTION IN PART OR AS A WHOLE WITHOUT THE WRITTEN PERMISSION OF BENDPAK INC. IS PROHIBITED.

DIMENSIONS ARE IN MM

NEXT ASSEMBLY 5260606

DETAIL B  
SCALE 1:20

DETAIL A  
SCALE 1:5

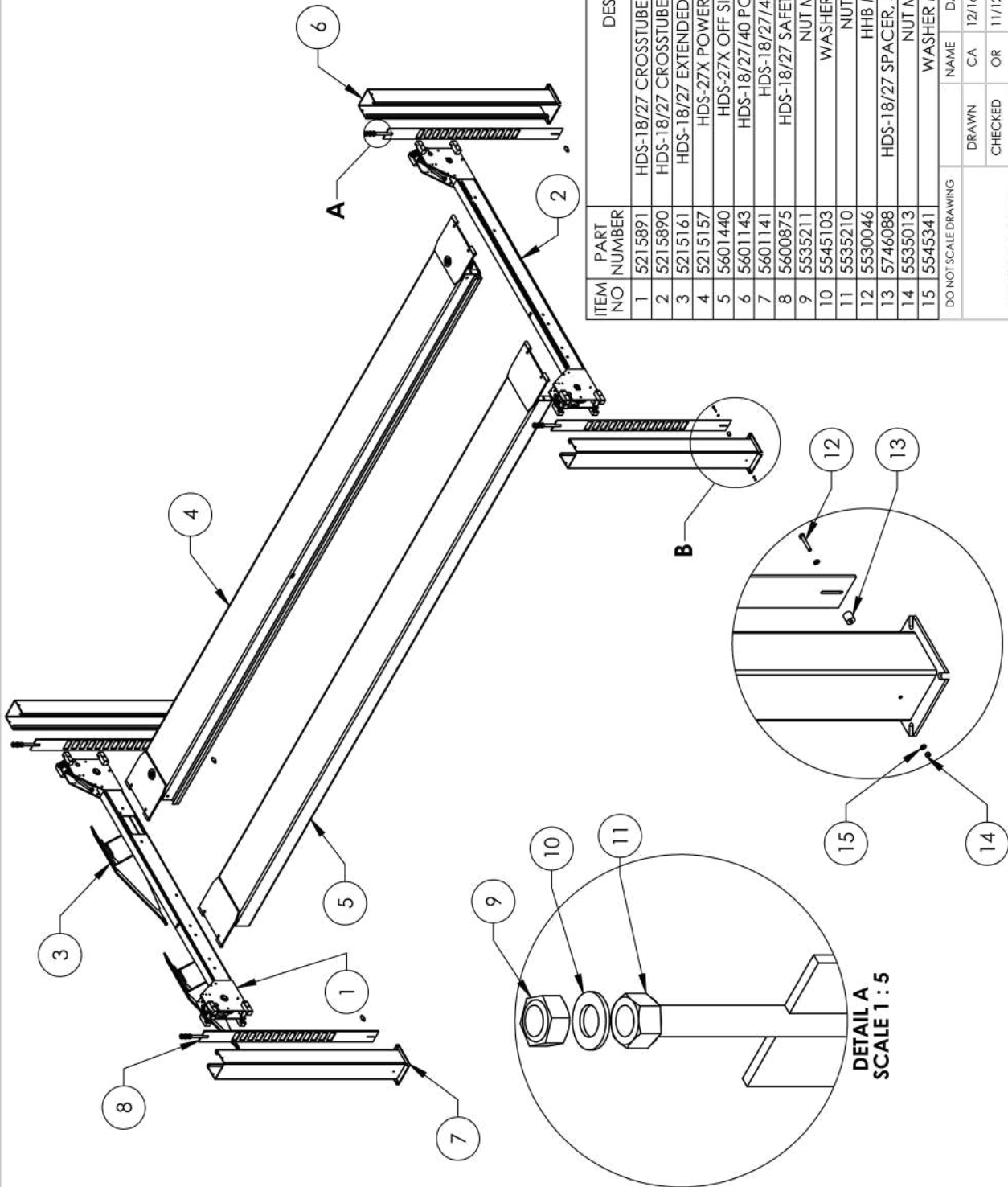

ITEM NO	PART NUMBER	DESCRIPTION	QTY	REV
1	5215891	HDS-18/27 CROSSTUBE ASSEMBLY, LARGE WINDOW	1	B
2	5215890	HDS-18/27 CROSSTUBE ASSEMBLY, SMALL WINDOW	1	B
3	5215161	HDS-18/27 EXTENDED DRIVE UP RAMP ASSEMBLY	2	J
4	5215157	HDS-27X POWER SIDE RAMP ASSEMBLY	1	V
5	5601440	HDS-27X OFF SIDE RAMP WELDMENT	1	A
6	5601143	HDS-18/27/40 POWER POST WELDMENT	1	B
7	5601141	HDS-18/27/40 POST WELDMENT	3	B
8	5600875	HDS-18/27 SAFETY LADDER WELDMENT	4	C
9	5535211	NUT M27 x 3.0 NL	4	-
10	5545103	WASHER M27 x .50mm	4	-
11	5535210	NUT M27 x 3.0	4	-
12	5530046	HHB M10x1.5x65	4	-
13	5746088	HDS-18/27 SPACER, SAFETY LADDER, 31mm LG	4	B
14	5535013	NUT M10 x 1.5 NL	4	-
15	5545341	WASHER M10 x Ø20 FLAT	8	-

DO NOT SCALE DRAWING

NAME	DATE
DRAWN	12/16/2019
CHECKED	OR 11/12/2020

THIRD ANGLE PROJECTION

BP BendPak.  
1645 LEMONWOOD DR.  
SANTA PAULA, CA 93060

TITLE: HDS-27X LIFT SUPERSTRUCTURE

SIZE DWG. NO. 5245086

REV C

SCALE: 1:60

SHEET 1 OF 1

PROPRIETARY AND CONFIDENTIAL  
THE INFORMATION CONTAINED IN THIS DRAWING IS THE PROPERTY OF BENDPAK INC. ANY REPRODUCTION IN PART OR AS A WHOLE WITHOUT THE WRITTEN PERMISSION OF BENDPAK INC. IS PROHIBITED.

SMILEY FACE SYMBOL

DIMENSIONS ARE IN MM

NEXT ASSEMBLY 5260602

DETAIL A  
SCALE 1 : 5

DETAIL B  
SCALE 1 : 20



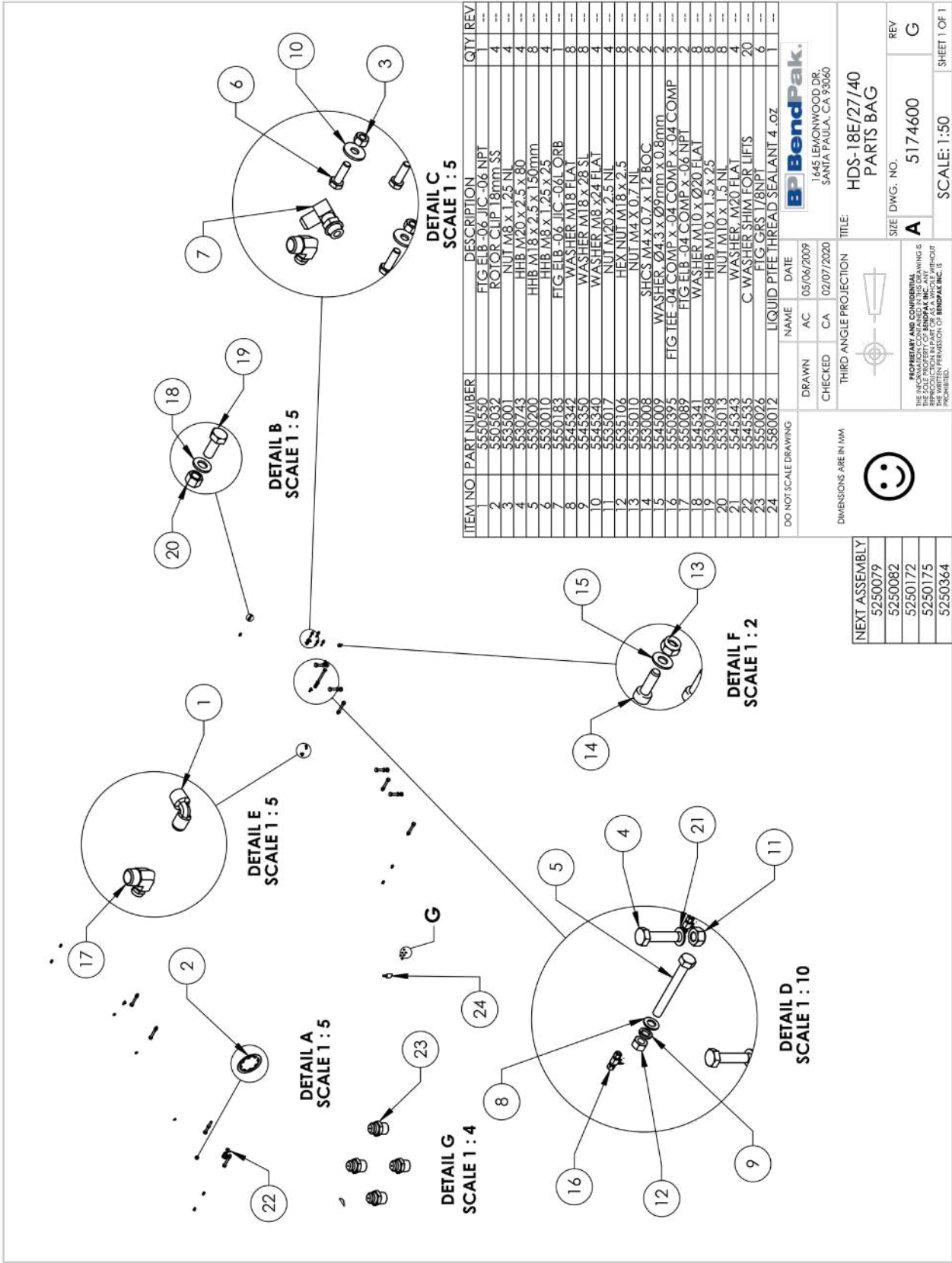

ITEM NO	PART NUMBER	DESCRIPTION	QTY	REV
1	5550550	FIG ELB-06 JIC-06 NPT	1	---
2	5505032	ROTOR CLIP 18mm SS	4	---
3	5535001	NUT M8 x 1.25 NL	4	---
4	5530743	HHB M20 x 2.5 x 80	4	---
5	5530700	HHB M18 x 2.5 x 150mm	4	---
6	5530010	HHB M8 x 1.25 x 2.5	4	---
7	5550183	FIG ELB-06 JIC-06L ORB	1	---
8	5545342	WASHER M18 FLAT	8	---
9	5545350	WASHER M18 x 28 SL	8	---
10	5545340	WASHER M8 x24 FLAT	4	---
11	5535017	NUT M20 x 2.5 NL	4	---
12	5535106	HEX NUT M18 x 2.5	8	---
13	5535010	NUT M4 x 0.7 NL	2	---
14	5530008	SHCS M4 x 0.7 x 12 BOC	2	---
15	5545009	WASHER Ø4.3 x Ø9mm x 0.8mm	2	---
16	5550395	FIG TEE-04 COMP x-04 COMP x-04 COMP	3	---
17	5550089	FIG ELB-04 COMP x-06 NPT	2	---
18	5545341	WASHER M10 x Ø20 FLAT	8	---
19	5530738	HHB M10 x 1.5 x 25	8	---
20	5535013	NUT M10 x 1.5 NL	8	---
21	5545343	WASHER M20 FLAT	4	---
22	5545353	C WASHER SHIM FOR LIFTS	20	---
23	5550693	FIG CSK 1/8NPT	4	---
24	5580012	LIQUID PIPE THREAD SEALANT 4 .07	6	---

DO NOT SCALE DRAWING

DRAWN	NAME	DATE
CHECKED	CA	02/07/2020

THIRD ANGLE PROJECTION

SMILEY FACE

PROPERTY AND CONFIDENTIAL DRAWING IS THE SOLE PROPERTY OF BENDPAK INC. ANY REPRODUCTION OR DISTRIBUTION WITHOUT THE WRITTEN PERMISSION OF BENDPAK INC. IS PROHIBITED.

**BendPak.**  
1645 LEMONWOOD DR.  
SANTA PAULA, CA 93060

TITLE: HDS-18E/27/40 PARTS BAG

SIZE DWG. NO. A 5174600

REV G

SCALE: 1:50

SHEET 1 OF 1

NEXT ASSEMBLY
5250079
5250082
5250172
5250175
5250364

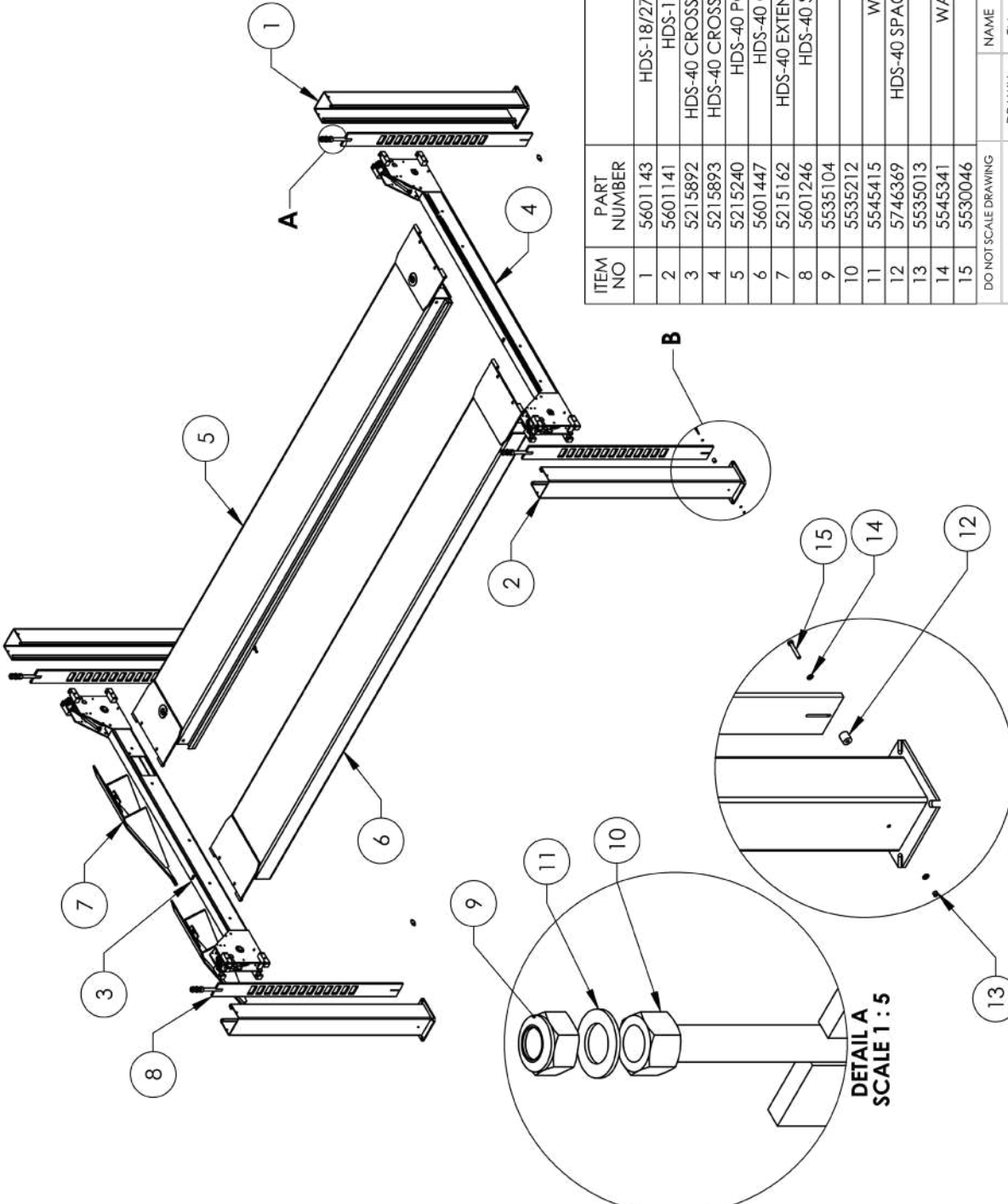

ITEM NO	PART NUMBER	DESCRIPTION	QTY	REV
1	5601143	HDS-18/27/40 POWER POST WELDMENT	1	B
2	5601141	HDS-18/27/40 POST WELDMENT	3	B
3	5215892	HDS-40 CROSSSTUBE ASSEMBLY, LARGE WINDOW	1	B
4	5215893	HDS-40 CROSSSTUBE ASSEMBLY, SMALL WINDOW	1	B
5	5215240	HDS-40 POWER SIDE RAMP ASSEMBLY	1	Z
6	5601447	HDS-40 OFF SIDE RAMP WELDMENT	1	A
7	5215162	HDS-40 EXTENDED DRIVE UP RAMP ASSEMBLY	2	G
8	5601246	HDS-40 SAFETY LADDER WELDMENT	4	A
9	5535104	NUT M30 x 3.5 NL	4	-
10	5535212	NUT M30 x 3.5	4	-
11	5545415	WASHER M30 x 56 FLAT	4	-
12	5746369	HDS-40 SPACER, SAFETY LADDER, 30mm LG	4	B
13	5535013	NUT M10 x 1.5 NL	4	-
14	5545341	WASHER M10 x Ø20 FLAT	8	-
15	5530046	HHB M10x1.5x65	4	-

DO NOT SCALE DRAWING

NAME: **BP BendPak®** DATE: 12/17/2019  
 TM: 12/17/2019  
 DRAWN: 11/12/2020  
 CHECKED: OR: 11/12/2020

THIRD ANGLE PROJECTION

1645 LEMONWOOD DR.  
 SANTA PAULA, CA 93060

TITLE: **HDS-40 LIFT SUPERSTRUCTURE**

SIZE DWG. NO. **A 5245091** REV **C**

SCALE: 1:60 SHEET 1 OF 1

PROPRIETARY AND CONFIDENTIAL  
 THE INFORMATION CONTAINED IN THIS DRAWING IS THE PROPERTY OF BENDPAK INC. ANY REPRODUCTION IN PART OR AS A WHOLE WITHOUT THE WRITTEN PERMISSION OF BENDPAK INC. IS PROHIBITED.

DETAIL B  
 SCALE 1 : 20

DETAIL A  
 SCALE 1 : 5

NEXT ASSEMBLY  
 5260607

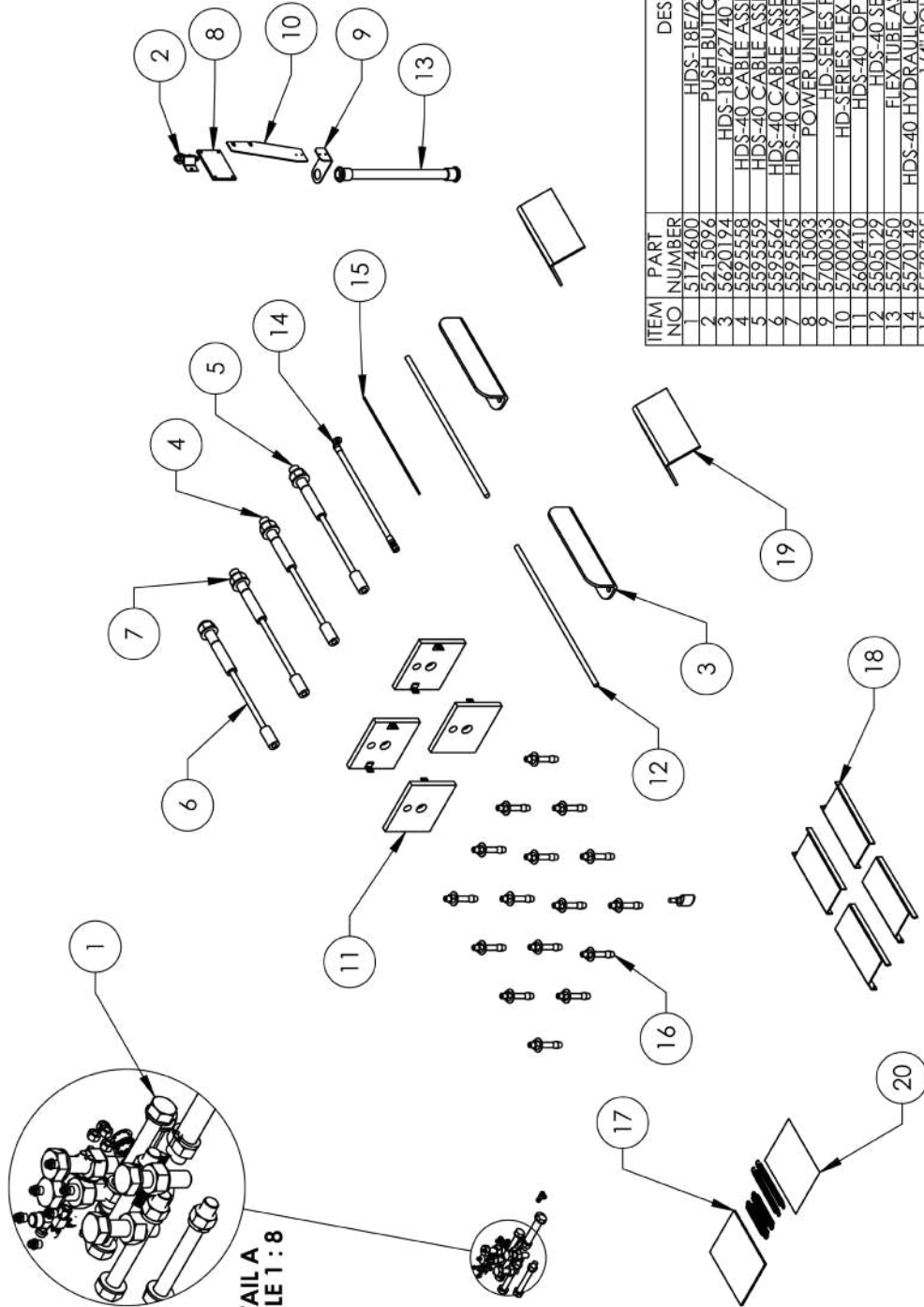

DETAIL A  
SCALE 1:8

ITEM NO	PART NUMBER	DESCRIPTION	QTY.	REV
1	5174600	HDS-18E/27/40 PARTS BAG	1	G
2	5215096	PUSH BUTTON AIR ASSEMBLY	1	G
3	5620194	HDS-18E/27/40 TIRE STOP WELDMENT	2	C
4	5595558	HDS-40 CABLE ASSEMBLY Ø19 x 41.02mm ST	1	B
5	5595559	HDS-40 CABLE ASSEMBLY Ø19 x 58.34mm ST	1	B
6	5595560	HDS-40 CABLE ASSEMBLY Ø19 x 94.52mm ST	1	B
7	5595561	HDS-40 CABLE ASSEMBLY Ø19 x 121.67mm ST	1	B
8	5715003	POWER UNIT VIBRATION DAMPENER	1	B
9	5700033	HD-SERIES FLEX TUBE ANGLE	1	E
10	5700029	HD-SERIES FLEX TUBE BRACKET PLATE	4	C
11	5600410	HDS-40 TOP PLATE WELDMENT	2	B
12	5505129	HDS-40 SERIES HINGE PIN	2	B
13	5570050	FLEX TUBE ASSEMBLY 1320mm	1	C
14	5570149	HDS-40 HYDRAULIC HOSE ASSY Ø10 x 538.5mm	1	C
15	5570795	1/4" POLY-FLO TUBING	24000mm*	-
16	5530456	AB 3/4" x 4 - 3/4"	16	-
17	5900160	HDS TRUCK SERIES INSTALLATION MANUAL	4	C
18	5716633	HDS-18/27/40 SERIES CROSSTUBE COVER-PLASTIC	4	C
19	5700246	WHEEL CHOCK	2	B
20	5210242	4 POST HEAVY DUTY CE PARTS BAG	1	A

DO NOT SCALE DRAWING

DRAWN TS 10/02/2018  
CHECKED OR 4/23/2020

THIRD ANGLE PROJECTION

BP BendPak.  
1645 LEMONWOOD DR.  
SANTA PAULA, CA 93060

TITLE:  
HDS-40 PARTS BOX

SIZE DWG. NO. A 5250079  
REV C

SCALE: 1:25 SHEET 1 OF 1

PROPRIETARY AND CONFIDENTIAL  
THE INFORMATION CONTAINED IN THIS DRAWING IS THE PROPERTY OF BENDPAK INC. ANY REPRODUCTION IN PART OR AS A WHOLE WITHOUT THE WRITTEN PERMISSION OF BENDPAK INC IS PROHIBITED.

SMILEY FACE

DIMENSIONS ARE IN MM

NEXT ASSEMBLY 5260607

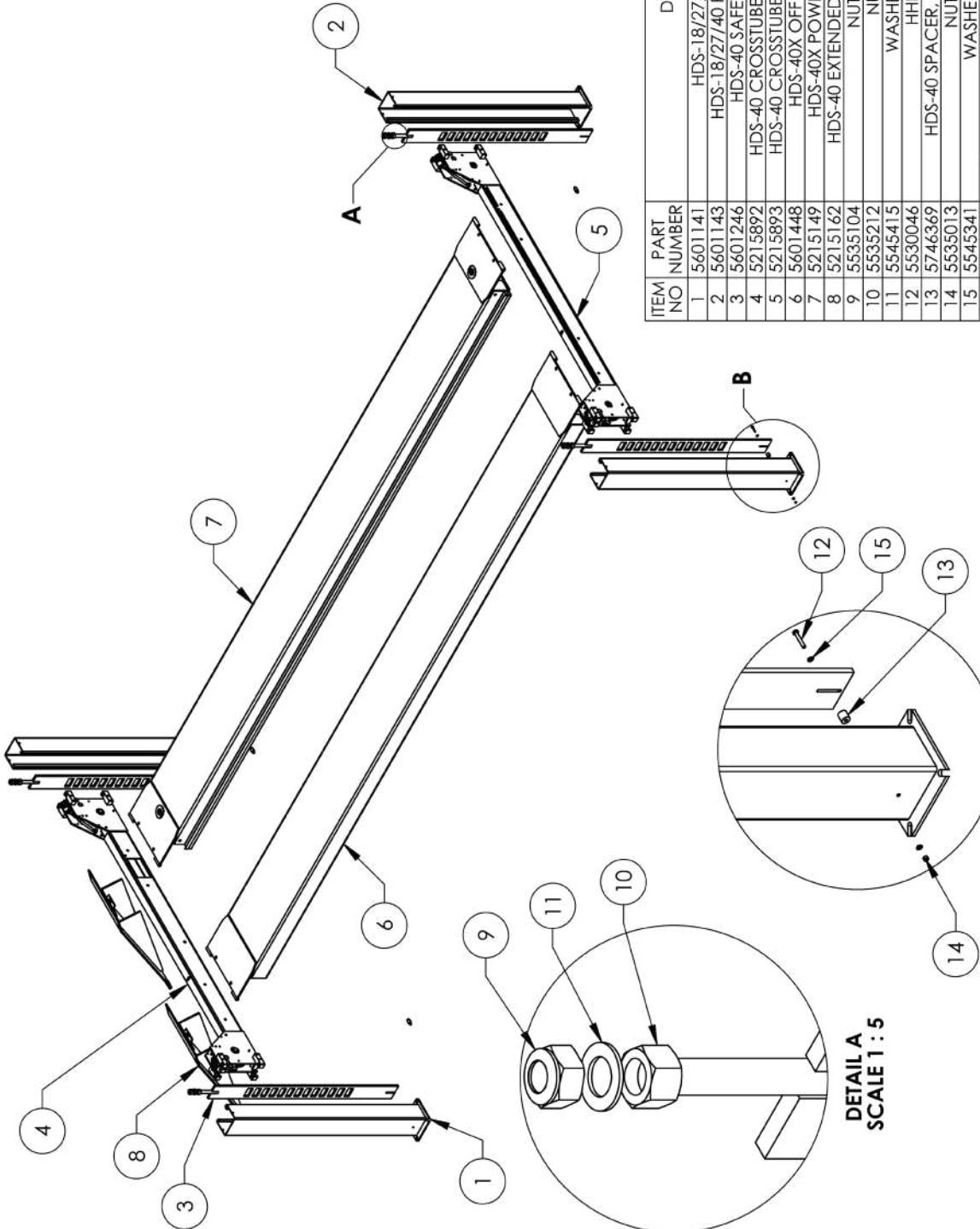

ITEM NO	PART NUMBER	DESCRIPTION	QTY	REV
1	5601141	HDS-18/27/40 POST WELDMENT	3	B
2	5601143	HDS-18/27/40 POWER POST WELDMENT	1	B
3	5601246	HDS-40 SAFETY LADDER WELDMENT	4	A
4	5215892	HDS-40 CROSSTUBE ASSEMBLY, LARGE WINDOW	1	B
5	5215893	HDS-40 CROSSTUBE ASSEMBLY, SMALL WINDOW	1	B
6	5601448	HDS-40X OFF SIDE RAMP WELDMENT	1	A
7	5215149	HDS-40X POWER SIDE RAMP ASSEMBLY	1	X
8	5215162	HDS-40 EXTENDED DRIVE UP RAMP ASSEMBLY	2	G
9	5535104	NUT M30 x 3.5 NL	4	-
10	5535212	NUT M30 x 3.5	4	-
11	5545415	WASHER M30 x 56 FLAT	4	-
12	5530046	HHB M10x1.5x65	4	-
13	5746369	HDS-40 SPACER, SAFETY LADDER, 30mm LG	4	B
14	5535013	NUT M10 x 1.5 NL	4	-
15	5545341	WASHER M10 x Ø20 FLAT	8	-

DO NOT SCALE DRAWING

BP BendPak.  
1645 LEVONWOOD DR.  
SANTA PAULA, CA 93060

DATE: 12/18/2019  
DRAWN: TM  
CHECKED: OR

THIRD ANGLE PROJECTION

TITLE: HDS-40X LIFT SUPERSTRUCTURE

SIZE: DWG. NO. 5245092

REV: C

SCALE: 1:60

SHEET 1 OF 1

PROPERTY AND CONFIDENTIAL INFORMATION CONTAINED IN THIS DRAWING IS THE SOLE PROPERTY OF BENDPAK INC. ALL RIGHTS RESERVED. NO REPRODUCTION OR TRANSMISSION OF THIS DRAWING IS PERMITTED WITHOUT THE WRITTEN PERMISSION OF BENDPAK INC. ©

SMILEY FACE

DIMENSIONS ARE IN MM

NEXT ASSEMBLY  
5260248



# EC Type-Examination Certificate



(Fm 210-017, Rev.10)

For the requirements of the Machinery Directive 2006/42/EC

For Annex IV machinery

**Certificate No.:** CE-C-20120209-01-06-5B  
**Date of first issue:** 2014.01.27  
**Date of last review:** 2019.01.27  
**Date of next review:** 2024.01.26

**NAME AND ADDRESS OF THE MANUFACTURER:** Bendpak Inc.  
 1645 E. Lemonwood Drive, Santa Paula, CA, United States of America

**PRODUCT DESCRIPTION/ TYPE AND MODEL:**  
 Range of 18,000lb (8165kg) 4 post vehicle servicing lifts  
 HDS-18E 154W x 297L x 93H in  
 Range of 27,000lb (12247kg) 4 post vehicle servicing lifts  
 HDS-27 154W x 295L x 60H in  
 HDS-27X 154W x 356L x 60H in  
 Range of 35,000lb (15876kg) 4 post vehicle servicing lifts  
 HDS-35 154W x 257L x 60H in  
 HDS-35X 154W x 357L x 60H in

**APPLICABLE STANDARDS:** EN1493:2010 Vehicle Lifts  
 EN 60204-1:2006+A1:2009 Safety of machinery - Electrical equipment of machines - Part1:General requirements

**A COPY IS AVAILABLE FROM:** CCQS UK Ltd., 5 Harbour Exchange, London, E14 9GE, UK

**SUBJECT TO THESE CONDITIONS:** A Rolling Jack is not included in this certification.

**RE-ISSUE HISTORY**  
 CE-C-20120209-01-06-5A first issue  
 CE-C-20120209-01-06-5B this issue – Review of original certification  
 HDS-18 renamed to HDS-18E, HDS-18X removed

*The technical file, accompanying documentation and the equipment which they describe have been found to be in compliance with the requirements of the Machinery Directive 2006/42/EC.*

*The responsible person defined above has responsibility for ensuring that all future serial manufacture of the machinery conforms to the sample submitted for EC type-examination referenced above.*

*Any changes to the design of the machinery certified here must be advised to CCQS UK Ltd. for re-assessment.*

*A CE marking should not be fixed to the equipment until the requirements of all relevant directives have been met.*

**Approved by:** Owen Bian – Office Manager 

**Date:** 2019.01.27

Appointed by UK Government  
as a Notified Body  
for CE Marking No. 1105

**CCQS UK Ltd.,**  
5 Harbour Exchange, Canary Wharf,  
London, E14 9GE, UK  
Tel: +44 (0) 20 7868 1509  
Email [info@ccqs.co.uk](mailto:info@ccqs.co.uk)

If in any doubt about the integrity of this certificate,  
please verify it on our website at  
<http://www.ccqs.co.uk>





# EC Type-Examination Certificate



(Fm 210-017, Rev.10)

For the requirements of the Machinery Directive 2006/42/EC

For Annex IV machinery

**Certificate No.:** CE-C-20120209-01-14-5A  
**Date of first issue:** 2019.05.30  
**Date of next review:** 2024.05.30

**NAME AND ADDRESS OF THE MANUFACTURER:** Bendpak Inc.  
 1645 E. Lemonwood Drive, Santa Paula, CA, United States of America

**PRODUCT DESCRIPTION/ TYPE AND MODEL:** Range of 40,000lb (18143kg) 4 post lifts  
 HDS-40  
 HDS-40X

**APPLICABLE STANDARDS:** EN1493:2010 Vehicle Lifts  
 EN 60204-1:2006+A1:2009 Safety of machinery - Electrical equipment of machines - Part1:General requirements

**A COPY IS AVAILABLE FROM:** CCQS UK Ltd., 5 Harbour Exchange, London, E14 9GE, UK

**RE-ISSUE HISTORY** CE-C-20120209-01-13-5A first issue

*The technical file, accompanying documentation and the equipment which they describe have been found to be in compliance with the requirements of the Machinery Directive 2006/42/EC.*

*The responsible person defined above has responsibility for ensuring that all future serial manufacture of the machinery conforms to the sample submitted for EC type-examination referenced above.*

*Any changes to the design of the machinery certified here must be advised to CCQS UK Ltd. for re-assessment.*

*A CE marking should not be fixed to the equipment until the requirements of all relevant directives have been met.*

**Approved by:** Owen Bian – Office Manager

**Date:** 2019.05.30

Appointed by UK Government  
 as a Notified Body  
 for CE Marking No. 1105

**CCQS UK Ltd.,**  
 5 Harbour Exchange, Canary Wharf,  
 London, E14 9GE, UK

Tel: +44 (0) 20 7868 1509  
 Email [info@ccqs.co.uk](mailto:info@ccqs.co.uk)

If in any doubt about the integrity of this certificate,  
 please verify it on our website at  
<http://www.ccqs.co.uk>



# CE Declaration of Conformity

The equipment which accompanies this declaration is in conformity with EU Directive: 2006/42/EC Machinery Directive

Manufacturer  
 BendPak Inc.  
 1645 Lemonwood Dr.  
 Santa Paula, CA 93060,  
 USA

A copy of the technical file for this equipment is available from:  
 CCGS UK Ltd.,  
 level 7, Westgate House, Westgate Rd.,  
 London W5 1YY UK

Description of Equipment:

Vehicle Servicing Lifts

Model	Capacity (lb)	Design	Width(in)	Legth(in)	Max Lift(in)
HDS-18	18,000	4 Post	154	247	60
HDS-18X	18,000	4 Post	154	363	60
HDS-27	27,000	4 Post	154	297	60
HDS-27X	27,000	4 Post	154	357	60
HDS-35	35,000	4 Post	154	297	60
HDS-35X	35,000	4 Post	154	357	60

A sample of this machinery has been presented to Notified Body number 1105.  
 CCGS UK Ltd., level 7, Westgate House, Westgate Rd., London W5 1YY UK  
 Who have issued an EC-type examination certificate  
 Number CE-GB-20120209-01-06-5A dated 2014.01.27

The equipment in respect of which this declaration is made conforms to the example to which that certificate relates, and that certificate remains valid.

The following harmonised standards have been used:-  
 EN 1493:2010 Vehicle Lifts

Authorised signatory of manufacturer

Signature: \_\_\_\_\_

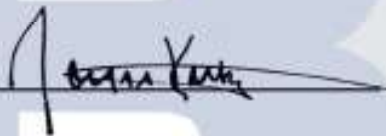

Name of signatory: Jeff Kritzer  
 Position in company: SVP Sales/Marketing

Place signed: Santa Paula CA  
 Date signed: 11.6.2013





For Parts Or Service  
Contact:

BendPak Inc. / Ranger Products  
1645 Lemonwood Dr.  
Santa Paula, CA. 93060

Tel: 1-805-933-9970  
Toll Free: 1-800-253-2363  
Fax: 1-805-933-9160

[www.bendpak.com](http://www.bendpak.com)

pn# 5900160

