

Service Manual

Service Parts & Diagrams

LR-60

BendPak SKU 5260167
LR-60 Production Lift
Version A
11/17/16

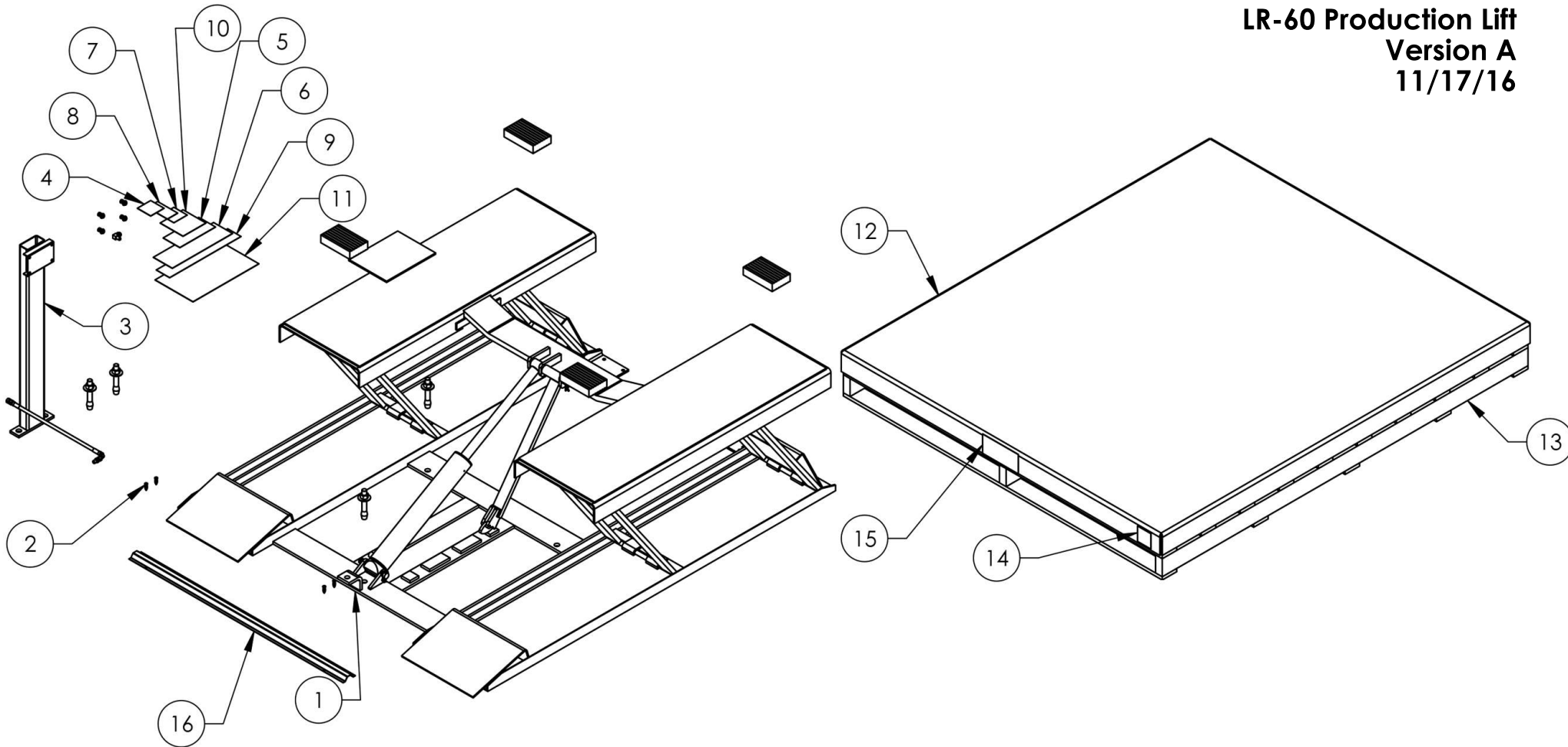

This guide is a troubleshooting reference used for maintaining and servicing your BendPak product. It provides comprehensive information on identifying serviceable parts and components and assists in troubleshooting problems and performing assembly/disassembly procedures.



BendPak, Inc. Corporate Office

1645 Lemonwood Drive
Santa Paula, CA 93060 USA
Toll Free US/Canada: 1-800-253-2363
Fax: 1-805-933-9160
info@bendpak.com

Customer Service Desk / Warranty

Customer Service Representatives
Office Tel: 1-805-933-9970
Toll Free US/Canada: 1-800-253-2363
Fax: 1-805-933-9160
customerservice@bendpak.com

Parts Orders

Customer Service Representatives
Office Tel: 1-805-933-9970
Toll Free US/Canada: 1-800-253-2363
Fax: 1-805-933-9160
parts@bendpak.com

Domestic Sales & Service

USA Sales Representatives
Office Tel: 1-805-933-9970
Toll Free US/Canada: 1-800-253-2363
Fax: 1-805-933-9160
sales@bendpak.com

International Sales & Service

Office Tel: 1-805-933-9970
Exports Department: 1-805-933-9970 Ext. 192
Toll Free US/Canada: 1-800-253-2363
Fax: 1-805-933-9160
bpkexports@bendpak.com

REV	DESCRIPTION	REVISION	DATE	EDITED BY	ECO#
M	ADDED 5781015, 5940007, 5905285, AND 5905970		01/04/2016	TM	00736
N	UPDATED BOM REVISION		03/21/2016	TM	00753
P	ADDED 5701310, UPDATED BOM REVISIONS		10/03/2016	TS	00781

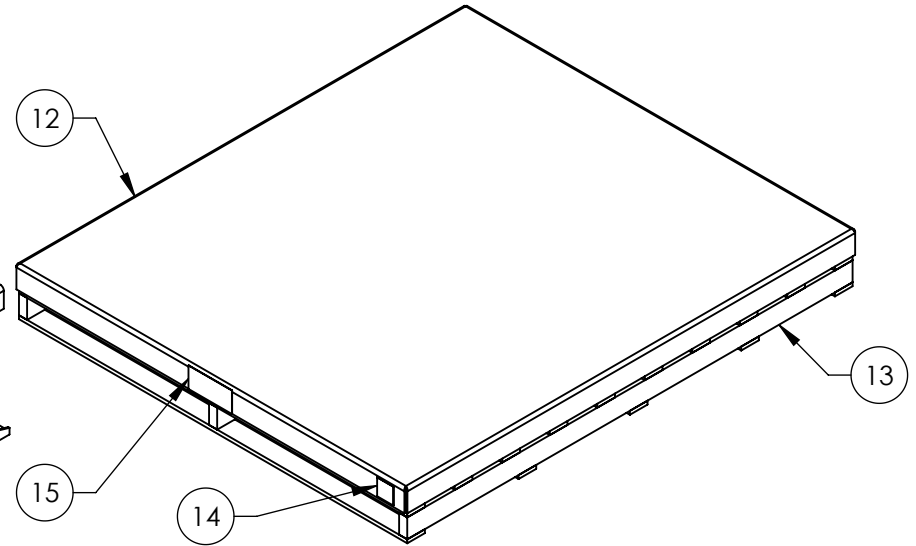
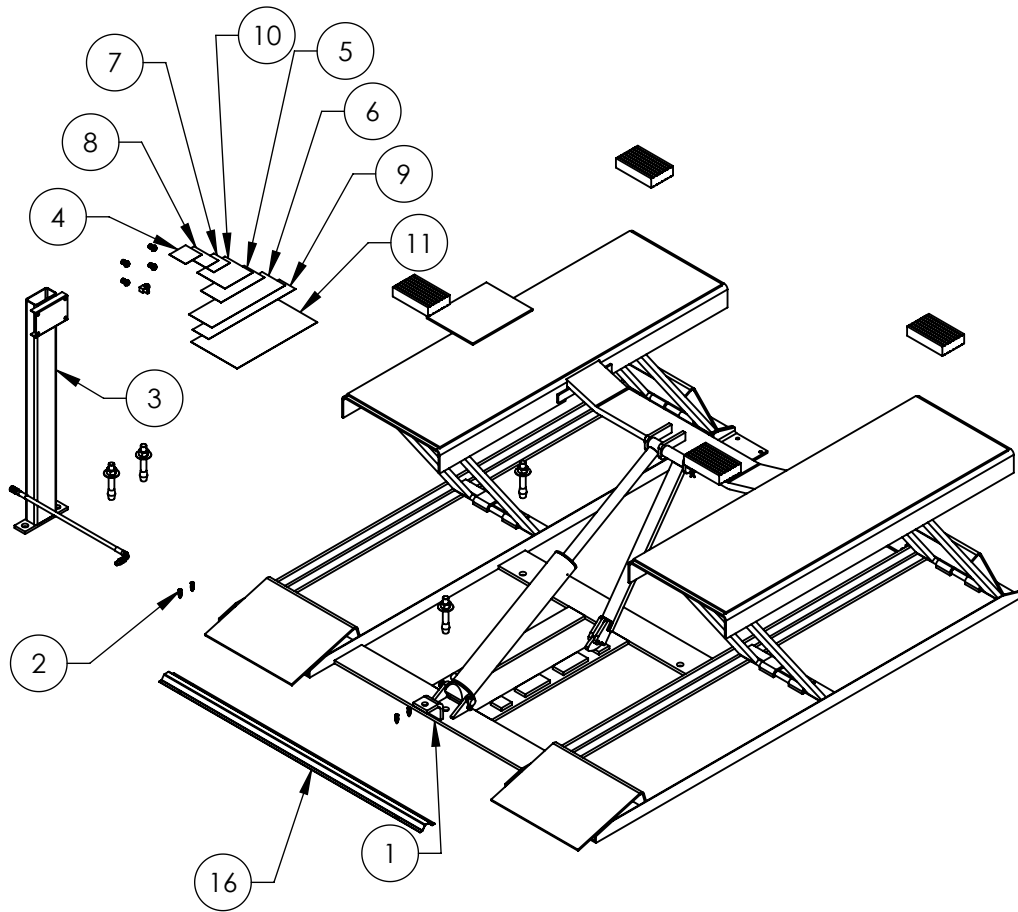

ITEM NO	PART NUMBER	DESCRIPTION	QTY	REV
1	5245233	LR-60/60P LIFT SUPERSTRUCTURE	1	J
2	5250021	LR-60 PARTS BOX	1	G
3	5600001	POWER UNIT STAND WELDMENT	1	A
4	5905176	WARNING TO PROLONG LIFE	1	--
5	5905721	WARNING MAX LIFTING CAP 6000LBS/2722 KG LABEL	1	--
6	5905240	WARNING TO RAISE LIFT	1	--
7	5905951	5905951-2015 Serial_Tag-B	1	--
8	5905940	PRODUCT DATA LABEL	1	--
9	5905204	BENDPAK LABEL	1	--
10	5905465	MANUFACTURER LABEL	1	--
11	5905135	CAUTION ALI/WL 300CSW	1	--
12	5781015	LR-60/60P CARRIER BOX	1	A
13	5940007	LR-60/60P PALLET ASSEMBLY	1	A
14	5905285	SERIALTAG EXTERIOR PEEL OFF INVENTORY LABEL	1	--
15	5905970	LR-60 PACKAGING LABEL	1	--
16	5701310	HYDRAULIC HOSE COVER	1	A

DO NOT SCALE DRAWING	NAME	DATE	1645 LEMONWOOD DR. SANTA PAULA, CA 93060
	DRAWN	TM 10/04/2010	
	CHECKED		
DIMENSIONS ARE IN MM 	THIRD ANGLE PROJECTION		TITLE: LR-60 PRODUCTION LIFT VER A
			SIZE DWG. NO. REV
<small>PROPRIETARY AND CONFIDENTIAL THE INFORMATION CONTAINED IN THIS DRAWING IS THE SOLE PROPERTY OF BENDPAK INC. ANY REPRODUCTION IN PART OR AS A WHOLE WITHOUT THE WRITTEN PERMISSION OF BENDPAK INC. IS PROHIBITED.</small>		A 5260167	P
SCALE: 1:25			SHEET 1 OF 2



NOTE: UNLESS OTHERWISE SPECIFIED.

1. SEE SHIPPING INSTRUCTIONS FOR FINAL PACKAGING
2. ALL LABELS TO BE APPLIED AFTER PAINTING.
3. SEE ATTACHED LABEL PLACEMENT SHEET

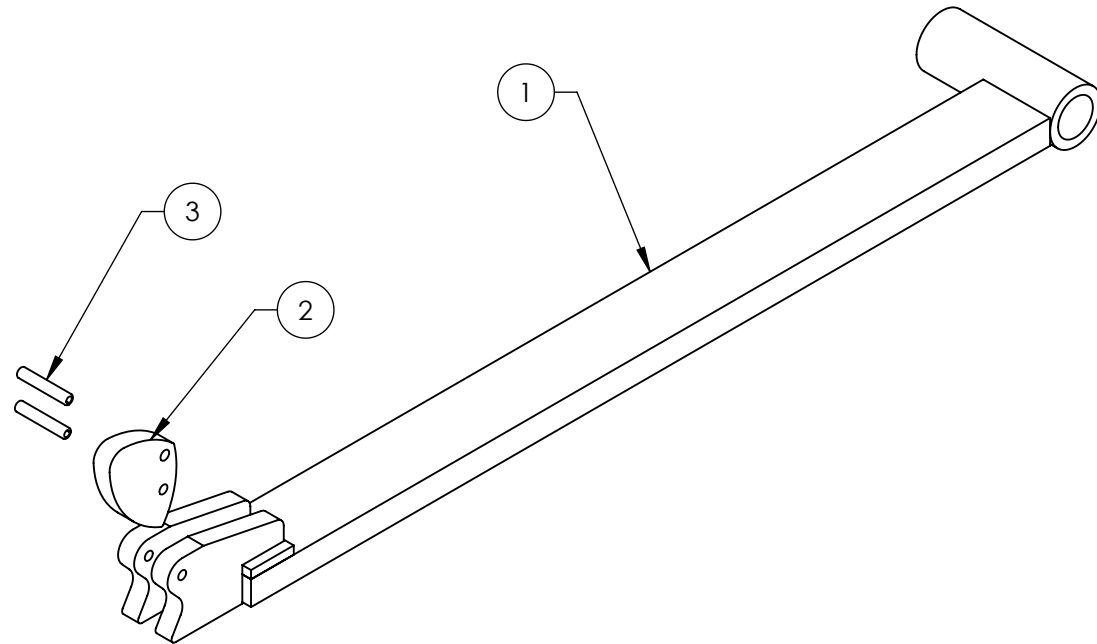
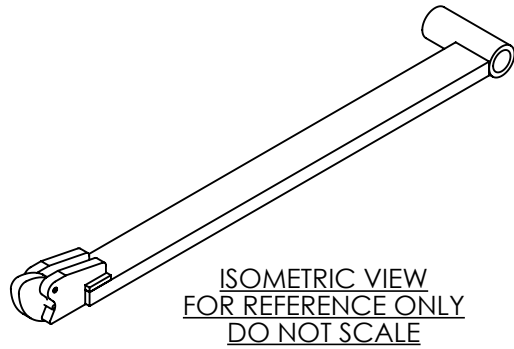
REV	DESCRIPTION	REVISION	DATE	EDITED BY	ECO#
A	PRODUCTION RELEASE, DERIVED FROM 5215594		04/14/2014	TS	00654
B	UPDATED BOM REVISION		09/18/2015	JM	00726

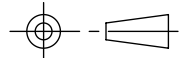

ITEM NO.	PART NUMBER	DESCRIPTION	QTY.	REV
1	5210372	LR-60/60P SAFETY BAR WELDMENT	1	C
2	5736676	LR-5T/LR-60 SAFETY LATCH	1	D
3	5505141	SPRING PIN M6 x 36	2	--

DO NOT SCALE DRAWING		NAME	DATE	 1645 LEMONWOOD DR. SANTA PAULA, CA 93060
DIMENSIONS ARE IN MM 		DRAWN	TS 04/14/2014	
		CHECKED	CA 09/28/2015	
		THIRD ANGLE PROJECTION		TITLE: LR-60/60P SAFETY BAR ASSEMBLY
				SIZE DWG. NO. REV
		<small> PROPRIETARY AND CONFIDENTIAL THE INFORMATION CONTAINED IN THIS DRAWING IS THE SOLE PROPERTY OF BENDPAK INC. ANY REPRODUCTION IN PART OR AS A WHOLE WITHOUT THE WRITTEN PERMISSION OF BENDPAK INC. IS PROHIBITED. </small>		A 5210373 B
			SCALE: 1:4	SHEET 1 OF 1

NOTE: UNLESS OTHERWISE SPECIFIED.



1. ASSEMBLE ITEMS AS SHOWN

NEXT ASSEMBLY
5245233

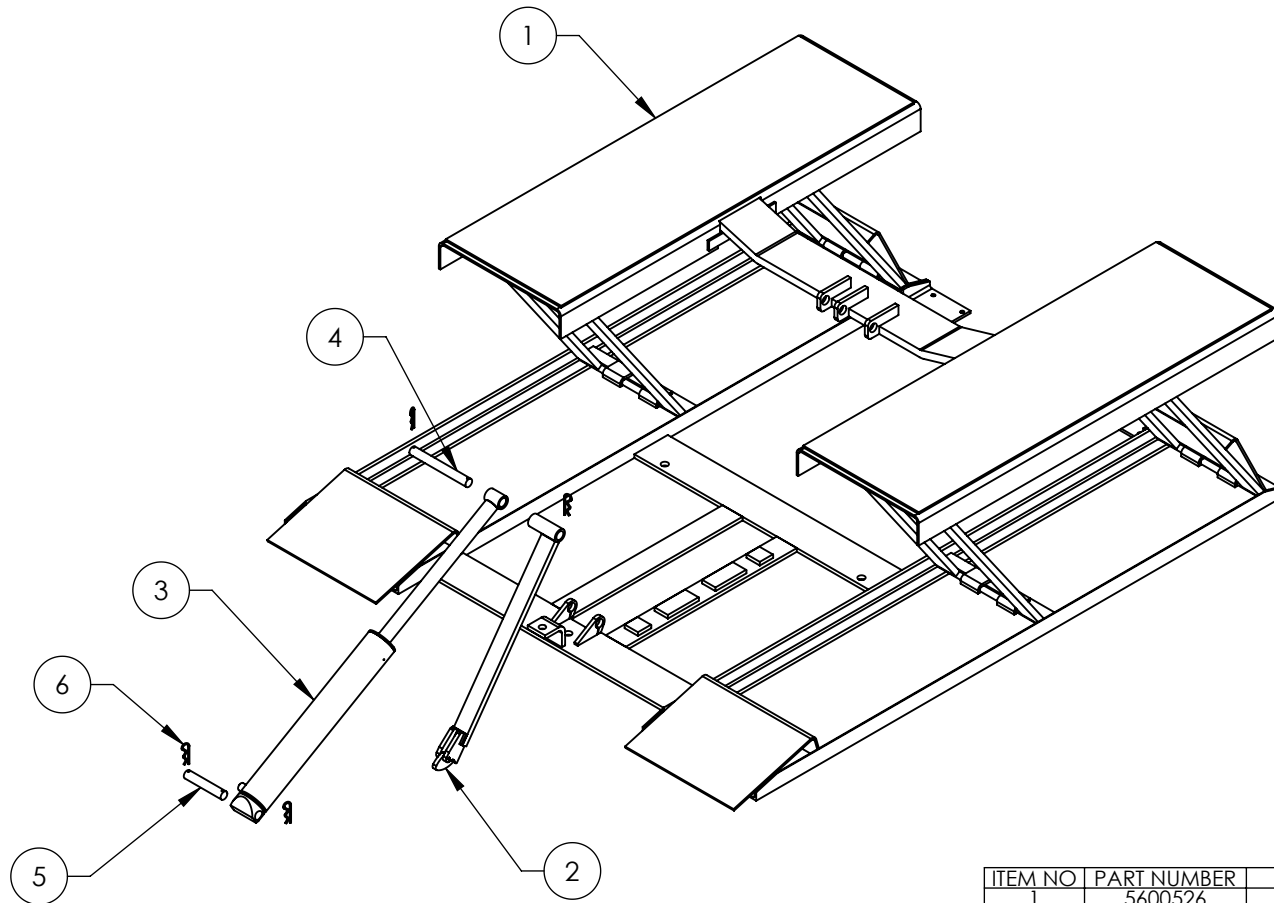
REVISION				
REV	DESCRIPTION	DATE	EDITED BY	ECO#
G	UPDATED BOM REVISIONS	09/18/2015	JM	00726
H	UPDATED BOM REVISION	12/11/2015	JM	00721
J	UPDATED BOM REVISION	03/21/2016	TM	00753

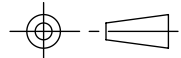

ITEM NO	PART NUMBER	DESCRIPTION	QTY	REV
1	5600526	LR-60/60P LIFT WELDMENT	1	H
2	5210373	LR-60/60P SAFETY BAR ASSEMBLY	1	B
3	5502135	CYLINDER ASSEMBLY Ø3.0 X 18	1	C
4	5746587	UPPER HINGE PIN	1	A
5	5746586	LR-60/60P LOWER CYLINDER CLEVIS PIN	1	A
6	5505350	MODEL#211 HAIR PIN/ LARGE	4	-

DO NOT SCALE DRAWING		NAME	DATE	 1645 LEMONWOOD DR. SANTA PAULA, CA 93060
DIMENSIONS ARE IN MM 		DRAWN	TM 10/04/2010	
		CHECKED	DB 06/29/2016	
THIRD ANGLE PROJECTION				TITLE: LR-60/60P LIFT SUPERSTRUCTURE
PROPRIETARY AND CONFIDENTIAL THE INFORMATION CONTAINED IN THIS DRAWING IS THE SOLE PROPERTY OF BENDPAK INC. ANY REPRODUCTION IN PART OR AS A WHOLE WITHOUT THE WRITTEN PERMISSION OF BENDPAK INC. IS PROHIBITED.		SIZE	DWG. NO.	REV
		A	5245233	J
SCALE: 1:20			SHEET 1 OF 1	

NOTE: UNLESS OTHERWISE SPECIFIED.



1. SEE SHIPPING INSTRUCTIONS FOR FINAL PACKAGING
2. ASSEMBLE ITEMS AS SHOWN

NEXT ASSEMBLY
5260167
5260168

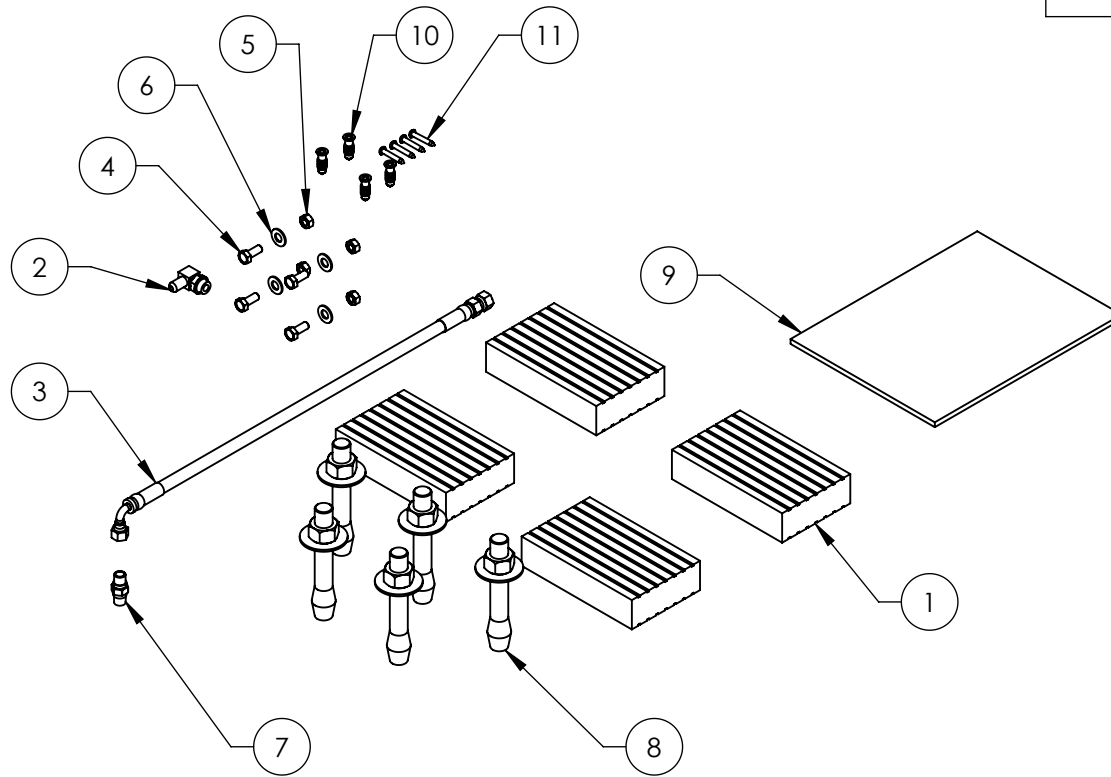
REVISION				
REV	DESCRIPTION	DATE	EDITED BY	ECO#
E	ADDED 5905721, REMOVED 5905760	10/24/2014	TM	00654
F	REMOVED 5900151, 5905135, 5905465, 5905204, 5905940, 5930790, 5905176, 5905240 & 5930609, UPDATED BOM REVISION	09/18/2015	JM	00726
G	REPLACED 5545012 WITH 5545021, REPLACED 5570013 WITH 5570082, ADDED 5535119, ADDED 5530201, UPDATED BOM, UPDATED NEXT ASSEMBLY	10/03/2016	TS	00781

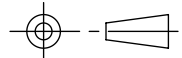

ITEM NO	PART NUMBER	DESCRIPTION	QTY	REV
1	5300845	LR-60/60P P-6 38mm (1.5") RUBBER PAD	4	A
2	5550103	FIG ELB -04 JIC -06 ORB	1	-
3	5570082	HOSE ASSY Ø6.4 x 2873mm SB	1	A
4	5530304	HHB M8 x 1.25 x 20	4	-
5	5535001	NUT M8 x 1.25 NL	4	A
6	5545021	WASHER M8 x Ø20 FLAT	4	-
7	5550147	FIG NPL -04 JIC x -04 NPT	1	-
8	5530456	AB 3/4" x 4 - 3/4"	5	-
9	5900337	LR-60/60P INSTALLATION MANUAL	1	-
10	5535119	M5 x 30mm FLOOR ANCHOR	4	B
11	5530201	RHPS M5 x 32mm	4	B

DO NOT SCALE DRAWING		NAME	DATE	 1645 LEMONWOOD DR. SANTA PAULA, CA 93060
DIMENSIONS ARE IN MM		DRAWN	TM 10/04/2010	
		CHECKED	CA 09/28/2015	
		THIRD ANGLE PROJECTION		TITLE: LR-60 PARTS BOX
				SIZE DWG. NO. REV
PROPRIETARY AND CONFIDENTIAL THE INFORMATION CONTAINED IN THIS DRAWING IS THE SOLE PROPERTY OF BENDPAK INC. ANY REPRODUCTION IN PART OR AS A WHOLE WITHOUT THE WRITTEN PERMISSION OF BENDPAK INC. IS PROHIBITED.		A 5250021 G		SCALE: 1:8 SHEET 1 OF 1

NOTE: UNLESS OTHERWISE SPECIFIED.

1. SEE SHIPPING INSTRUCTIONS FOR FINAL PACKAGING

NEXT ASSEMBLY
5260167

REVISION				
REV	DESCRIPTION	DATE	EDITED BY	ECO#
A	DERIVED FROM 5570013, PRODUCTION RELEASE	10/05/2016	TS	00781

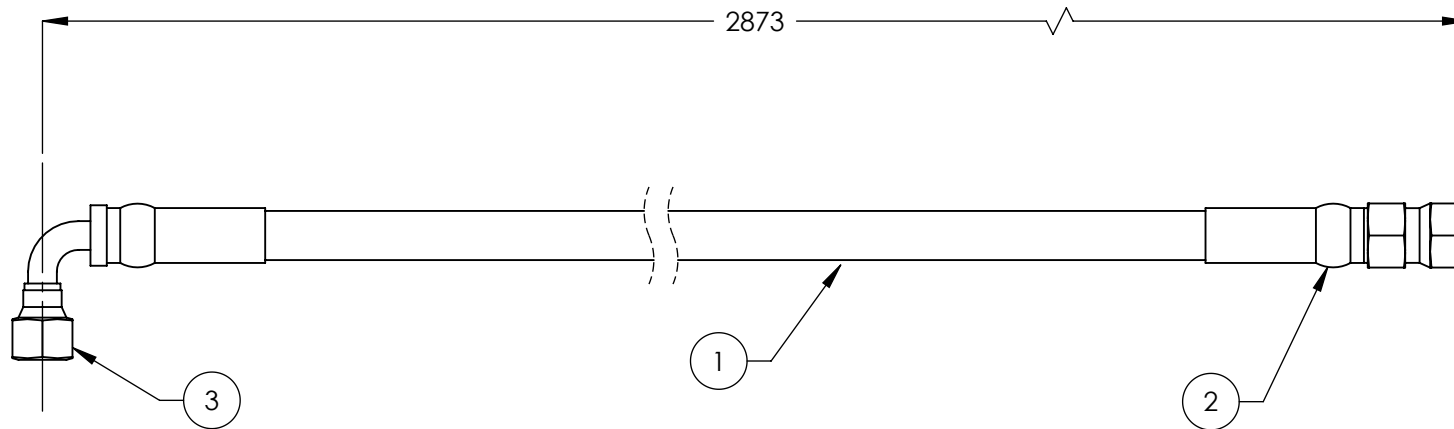

ITEM NO	PART NUMBER	DESCRIPTION	QTY	REV
1	5570129	Ø6.4 ID HYDRAULIC HOSE	2819mm*	-
2	5550325	FTG NPL Ø1/4 CRIMP x -04 JIC	1	-
3	5550345	FTG ELB Ø1/4 CRIMP x -04 JIC	1	-

DO NOT SCALE DRAWING		NAME	DATE	1645 LEMONWOOD DR. SANTA PAULA, CA 93060
		DRAWN	TS 10/05/2016	
		CHECKED		
DIMENSIONS ARE IN MM TOLERANCES: 0. = ±1.5 0.0 = ±1.0 0.00 = ±0.25 0.000 = ±0.13 ANGULAR: MACH ±2° SURFACE FINISH 1.6 ISO Ra µm FOR MACHINED SURFACES UNLESS OTHERWISE SPECIFIED		THIRD ANGLE PROJECTION 		TITLE: HOSE ASSY Ø6.4 x 2873mm SB
NEXT ASSEMBLY 5250020 5250021		PROPRIETARY AND CONFIDENTIAL THE INFORMATION CONTAINED IN THIS DRAWING IS THE SOLE PROPERTY OF BENDPAK INC. ANY REPRODUCTION IN PART OR AS A WHOLE WITHOUT THE WRITTEN PERMISSION OF BENDPAK INC. IS PROHIBITED.		SIZE DWG. NO. REV A 5570082 A
SCALE: 1:2			SHEET 1 OF 1	

NOTE: UNLESS OTHERWISE SPECIFIED.

- ITEM 1 SPECIFICATIONS ARE FOUND ON PART SPECIFICATION FORM
- (*)HOSE LENGTH PROVIDED FOR REFERENCE ONLY

REVISION				
REV	DESCRIPTION	DATE	EDITED BY	ECO#
G	ADDED 5580007 ADHESIVE TO NOTE 5	12/11/2015	JM	00721
H	UPDATED BOM REVISIONS	03/21/2016	TM	00753
J	UPDATED BOM REVISIONS	10/06/2016	TS	00781

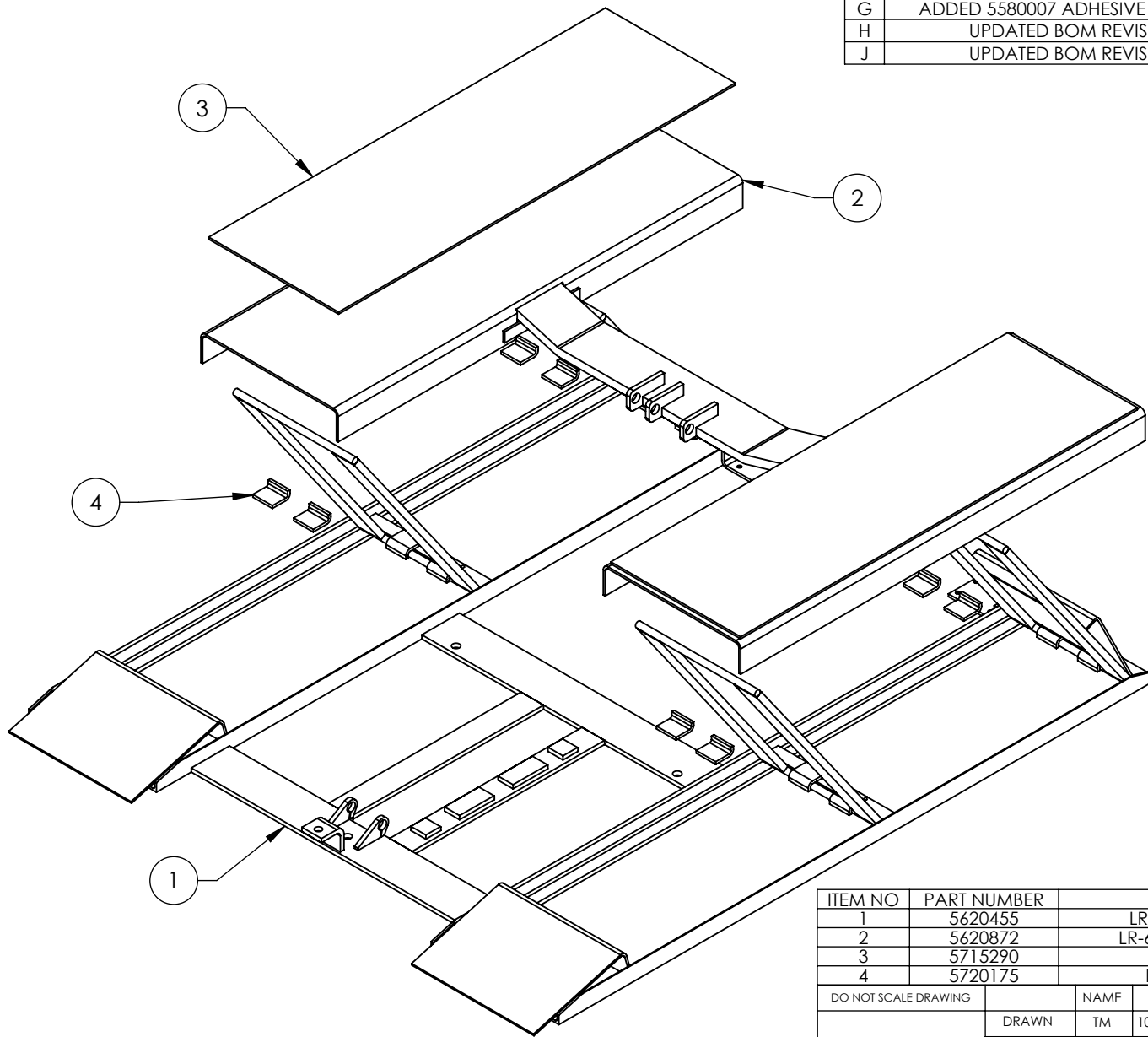

NOTE: UNLESS OTHERWISE SPECIFIED.

1. BREAK AND DEBURR ALL SHARP EDGES 0.3mm
2. REMOVE ALL WELD SPLATTER
3. DIMENSIONS SHOWN ARE AFTER PAINTING
4. PAINT BENDPAK BLUE
5. ADHERE RUBBER TOP PAD AFTER WELDING AND PAINTING USING 5580007 ADHESIVE

ITEM NO	PART NUMBER	DESCRIPTION	QTY	REV
1	5620455	LR-60/60P BASE WELDMENT	1	G
2	5620872	LR-60/60P COVER WELDMENT	1	C
3	5715290	RUBBER TOP PAD	2	B
4	5720175	LR-60/P HINGE HOLDER	8	-

DO NOT SCALE DRAWING		NAME	DATE	1645 LEMONWOOD DR. SANTA PAULA, CA 93060
DIMENSIONS ARE IN MM TOLERANCES: 0. = ±1.5 0.0 = ±0.5		DRAWN	TM 10/01/2010	
ANGULAR: 0. = ±2° SURFACE FINISH 1.6 ISO Ra μm FOR MACHINED SURFACES UNLESS OTHERWISE SPECIFIED		CHECKED	DB 06/29/2016	
		THIRD ANGLE PROJECTION		TITLE:
				LR-60/60P LIFT WELDMENT
		PROPRIETARY AND CONFIDENTIAL THE INFORMATION CONTAINED IN THIS DRAWING IS THE SOLE PROPERTY OF BENDPAK INC. ANY REPRODUCTION IN PART OR AS A WHOLE WITHOUT THE WRITTEN PERMISSION OF BENDPAK INC. IS PROHIBITED.		SIZE DWG. NO.
		NEXT ASSEMBLY 5245233		A 5600526
				REV
				J
		SCALE: 1:15		SHEET 1 OF 2

		REVISION		
REV	DESCRIPTION	DATE	EDITED BY	ECO#
E	REPLACED 5620454 WITH 5620137, ADDED 5735422 AND 5720175, UPDATED BOM REVISIONS	04/15/2014	TS	00654
F	UPDATED BOM REVISION	03/21/2016	TM	00753
G	UPDATED BOM REVISION	10/06/2016	TS	00781

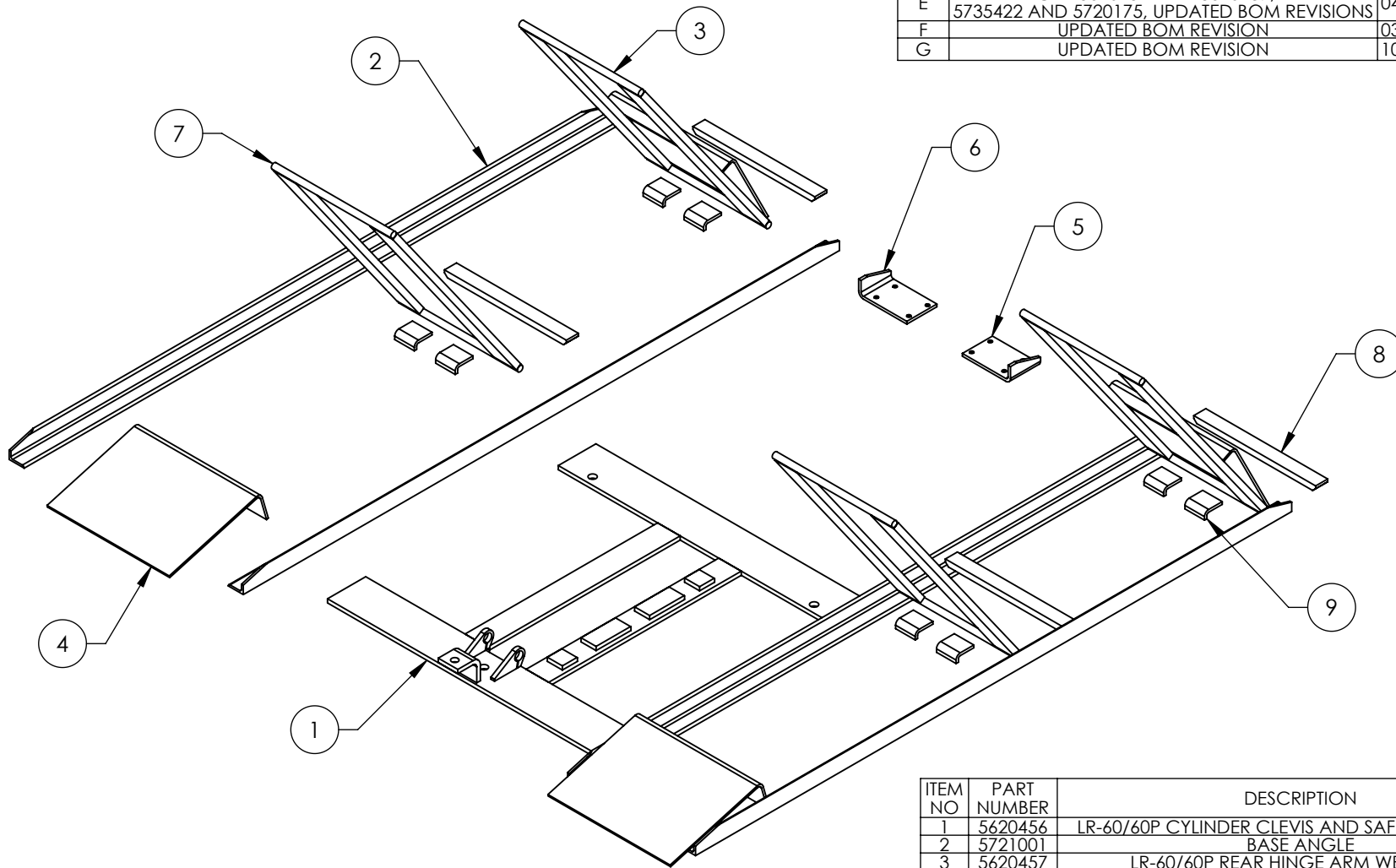

ITEM NO	PART NUMBER	DESCRIPTION	QTY	REV
1	5620456	LR-60/60P CYLINDER CLEVIS AND SAFETY WELDMENT	1	C
2	5721001	BASE ANGLE	4	A
3	5620457	LR-60/60P REAR HINGE ARM WELDMENT	2	D
4	5701331	LR-60/60P DRIVE ON RAMP	2	A
5	5736343	LR-60P WHEEL SUPPORT ANGLE RH	1	A
6	5736344	LR-60P WHEEL SUPPORT ANGLE LH	1	A
7	5620137	LR-60/60P HINGE ARM WELDMENT	2	D
8	5735422	LR-60/P,P-6/F HINGED ARM STOP BAR	4	B
9	5720175	LR-60/P HINGE HOLDER	8	C

DO NOT SCALE DRAWING		NAME	DATE	1645 LEMONWOOD DR. SANTA PAULA, CA 93060
		DRAWN	TM 09/29/2010	
		CHECKED	DB 06/29/2016	
DIMENSIONS ARE IN MM TOLERANCES: 0. = ±1.5 0.0 = ±0.5 ANGULAR: 0. = ±2° SURFACE FINISH 1.6 ISO Ra μm FOR MACHINED SURFACES UNLESS OTHERWISE SPECIFIED		THIRD ANGLE PROJECTION 		TITLE: LR-60/60P BASE WELDMENT
		SIZE	DWG. NO.	REV
		A	5620455	G
SCALE: 1:15			SHEET 1 OF 4	

NOTE: UNLESS OTHERWISE SPECIFIED.

1. BREAK AND DEBURR ALL SHARP EDGES 0.3mm
2. REMOVE ALL WELD SPLATTER

NEXT ASSEMBLY
5600526

PROPRIETARY AND CONFIDENTIAL
 THE INFORMATION CONTAINED IN THIS DRAWING IS
 THE SOLE PROPERTY OF BENDPAK INC. ANY
 REPRODUCTION IN PART OR AS A WHOLE WITHOUT
 THE WRITTEN PERMISSION OF BENDPAK INC. IS
 PROHIBITED.

REV	DESCRIPTION	REVISION	DATE	EDITED BY	ECO#
A	PRODUCTION RELEASE, DERIVED FROM T1031		10/01/2010	TM	00406
B	REPLACED 5620003 WITH 5735422, UPDATED BOM REVISION		04/15/2014	TS	00654
C	ADDED 5735619, UPDATED NEXT ASSEMBLY		10/07/2016	TS	00781

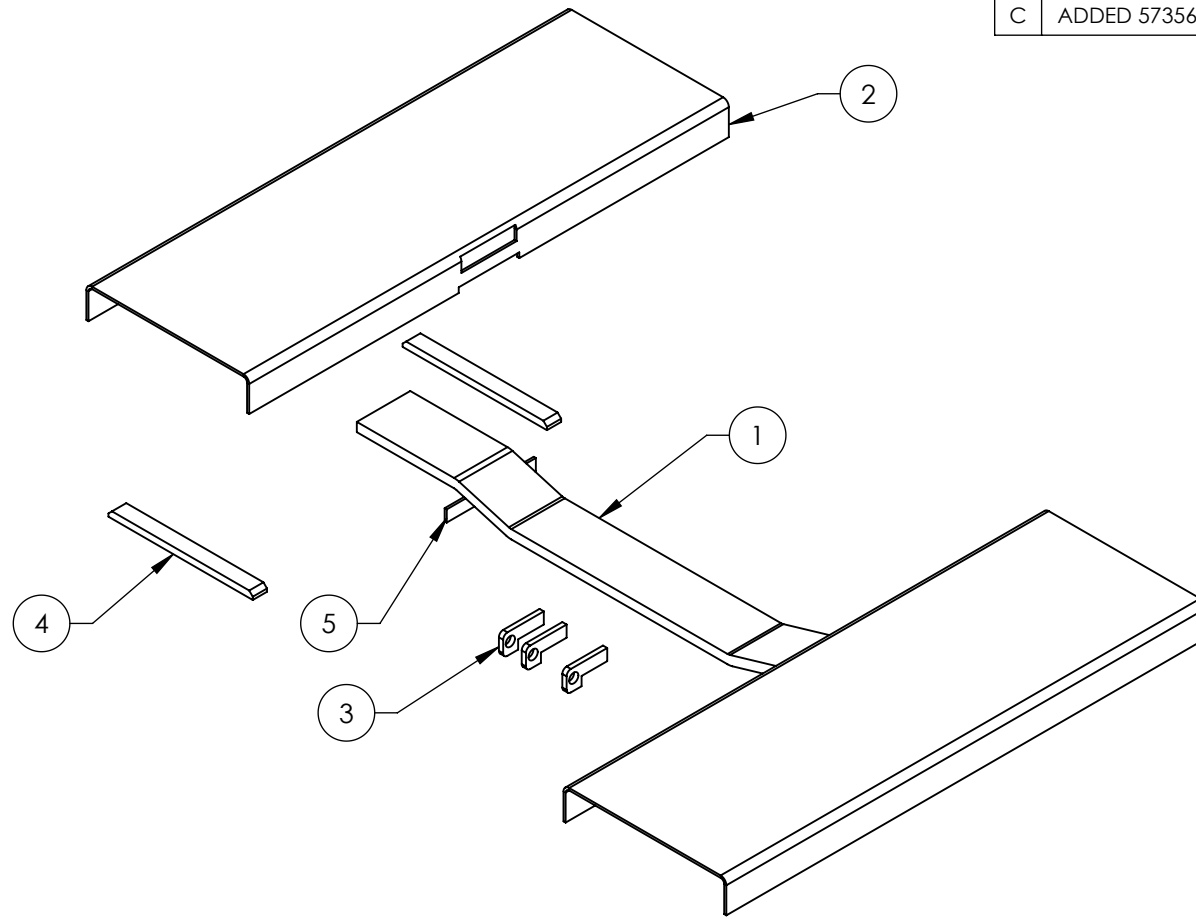

ITEM NO	PART NUMBER	DESCRIPTION	QTY	REV
1	5736342	LR-60/60P PUSH BAR	1	A
2	5701333	LR-60/60P RAMP COVER	2	A
3	5736338	LR-60/60P TOP CLEVIS	3	A
4	5735422	LR-60/P,P-6/F HINGED ARM STOP BAR	4	B
5	5735619	LR-60/60P COVER REINFORCEMENT STRIP	2	A

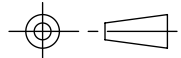
DO NOT SCALE DRAWING	NAME	DATE	 1645 LEMONWOOD DR. SANTA PAULA, CA 93060	
DIMENSIONS ARE IN MM TOLERANCES: 0. = ±1.5 0.0 = ±0.5 ANGULAR: 0. = ±2° SURFACE FINISH 1.6 ISO Ra μm FOR MACHINED SURFACES UNLESS OTHERWISE SPECIFIED	DRAWN	TM		10/01/2010
	CHECKED	TM		
THIRD ANGLE PROJECTION				TITLE:
				LR-60/60P COVER WELDMENT
		SIZE	DWG. NO.	REV
		A	5620872	C
			SCALE: 1:15	SHEET 1 OF 2

NOTE: UNLESS OTHERWISE SPECIFIED.

1. BREAK AND DEBURR ALL SHARP EDGES 0.3mm
2. REMOVE ALL WELD SPLATTER

NEXT ASSEMBLY
5600526

PROPRIETARY AND CONFIDENTIAL
 THE INFORMATION CONTAINED IN THIS DRAWING IS
 THE SOLE PROPERTY OF BENDPAK INC. ANY
 REPRODUCTION IN PART OR AS A WHOLE WITHOUT
 THE WRITTEN PERMISSION OF BENDPAK INC. IS
 PROHIBITED.



PART SPECIFICATION FORM

BENDPAK Number:	5900337
MRP Description:	LR-60/60P INSTALLATION MANUAL
Date:	12/28/2010
ECO :	00431

1. Engineering Specification

Application:
 INSTALLATION MANUAL

Detailed Description:

 <p>WARNING</p>	<p>PLEASE READ THE ENTIRE CONTENTS OF THIS MANUAL PRIOR TO INSTALLATION AND OPERATION. BY PROCEEDING YOU AGREE THAT YOU FULLY UNDERSTAND AND COMPREHEND THE FULL CONTENTS OF THIS MANUAL. FORWARD THIS MANUAL TO ALL OPERATORS. FAILURE TO OPERATE THIS EQUIPMENT AS DIRECTED MAY CAUSE INJURY OR DEATH.</p> <p style="text-align: right;">REV E 06-21-10 pm 5900337</p>
 <p>CAUTION</p> <p>The safe operating temperature range for this product is 41° F. - 124° F.</p>	

INSTALLATION AND OPERATION MANUAL

**6,000 POUND CAPACITY
 LOW RISE LIFT
 MODELS:
 LR-60
 LR-60P**

READ FIRST



Do not operate this machine until you read and understand all the dangers, warnings and cautions in this manual.



Keep this operation manual near the machine at all times. Make sure that **ALL USERS** read this manual.

SHIPPING DAMAGE CLAIMS
 When this equipment is shipped, title passes to the purchaser upon receipt from the carrier. Consequently, claims for the material damaged in shipment must be made by the purchaser against the transportation company at the time shipment is received.

BE SAFE
 Your new lift was designed and built with safety in mind. However, your overall safety can be increased by proper training and thoughtful operation on the part of the operator. **DO NOT** operate or repair this equipment without reading this manual and the important safety instructions shown inside.

2. Vendor Information

Approved Vendor	Vendor Part #	Contact #	Preferred Vendor
1)			

PART SPECIFICATION FORM

BENDPAK Number:	5905135
MRP Description:	CAUTION ALI/WL 300CSW
Date:	12/28/2010
ECO :	00431

1. Engineering Specification

Application:

ALI SCISSOR LIFT STICKER

Detailed Description:



2. Vendor Information

Approved Vendor	Vendor Part #	Contact #	Preferred Vendor
1)			

PART SPECIFICATION FORM

BENDPAK Number:	5905176
MRP Description:	WARNING TO PROLONG LIFE
Date:	10/24/2014
ECO :	00654

1. Engineering Specification

Application:

SCISSOR CYLINDER WARNING

Detailed Description:



SIZE: 3" L x 3" W (76mm x 76mm)

- Material: White Vinyl Pressure Sensitive Adhesive
- Thickness: 4 Mil
- Ink: U.V. protected CMYK 2/C Process
- Finish: Polished
- Print Process: Offset Lithography - 200 line-screen or 300 p.p.i. for digital
- Lamination: Clear-gloss over-laminate for abrasion, chemical, and ultra violet protection

2. Vendor Information

Approved Vendor	Vendor Part #	Contact #	Preferred Vendor
1)			

PART SPECIFICATION FORM

BENDPAK Number:	5905204
MRP Description:	BENDPAK LABEL
Date:	09/16/2015
ECO :	00715

1. Engineering Specification
<p><u>Application:</u> BENDPAK LABEL</p>
<p><u>Detailed Description:</u></p> <div style="text-align: center;">  </div> <p><u>Material:</u> Clear Adhesive PET <u>Size:</u> 16"W x 3"H <u>Thickness:</u> 4 Mil <u>Finish:</u> Polished <u>Ink:</u> U.V. protected, Opaque White <u>Print Process:</u> Silk Screen, 85 line-screen (YELLOW color in file represents what should be clear PET material and SHOULD NOT print as YELLOW ink. White area in file represents Opaque White ink.) <u>Lamination:</u> Clear-gloss over-laminate for abrasion, chemical, and ultra violet protection</p>

2. Vendor Information			
Approved Vendor	Vendor Part #	Contact #	Preferred Vendor
1)			

PART SPECIFICATION FORM

BENDPAK Number:	5905240
MRP Description:	WARNING TO RAISE LIFT
Date:	10/24/2014
ECO :	00654

1. Engineering Specification





Application:

OPERATION INSTRUCTIONS

Detailed Description:

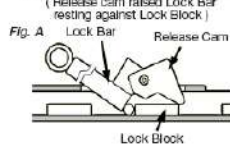
SIZE: 13.5" L x 4.25" W (343mm x 108mm)

- Material: White Vinyl Pressure Sensitive Adhesive
- Thickness: 4 Mil
- Ink: U.V. protected CMYK 2/C Process
- Finish: Polished
- Print Process: Offset Lithography - 200 line-screen or 300 p.p.i. for digital
- Lamination: Clear-gloss over-laminate for abrasion, chemical, and ultra violet protection

<p>⚠ WARNING Read and understand all safety warning and operation procedures before using lift. Keep hands and feet clear from moving parts.</p> <p style="text-align: center;">OPERATION INSTRUCTIONS</p> <p>TO RAISE LIFT:</p> <ul style="list-style-type: none"> • Clear area of personnel and make sure lift is in full lowered position. • Drive vehicle over lift making sure center line of the vehicle is positioned properly over lift pads. • Position lift pads underneath the vehicle making sure that they make secure contact with the factory recommended lifting points. • Before raising, make sure the weight of the vehicle does not exceed rated capacity of lift. • Push the RAISE button to commence lifting. • Raise lift until the vehicles tires clear the floor. • Stop then check if vehicle is secure and the lifting pads are still in contact with the frame. 	<ul style="list-style-type: none"> • Continue raising vehicle to desired height. • Raise until the safety lock bars drop into the LOCKED position as described on <i>Fig. A</i> • Raise the lift to the desired height then lower the lift until the LOCK BARS rests against the LOCK BLOCK. <p>TO LOWER LIFT:</p> <ul style="list-style-type: none"> • Clear area before lowering lift. • Raise the lift until the release cam drops into the UNLOCKED position as described on <i>Fig. B</i> • Push the LOWERING handle until the lift starts to descend. Stay clear of lift area. • Fully lower the lift and remove all lifting adapters before driving vehicle away. <p style="text-align: center;">⚠ WARNING ALWAYS ensure that the safety is in LOCKED position before any attempt is made to work on or near the vehicle.</p>	<p>SAFETY IN LOCKED POSITION (Release cam raised Lock Bar resting against Lock Block)</p> <p><i>Fig. A</i></p>  <p>SAFETY IN UNLOCKED POSITION (Release cam lowered)</p> <p><i>Fig. B</i></p> 	<p>⚠ WARNING Drive car completely over lift</p>  <p>NEVER OVERLOAD LIFT Check for 1" minimum clearance between car and lift before raising.</p>  <p>DO NOT park on, or load lift in a fully lowered position or damage may result.</p> <p style="text-align: right; font-size: small;">PN 6005240</p>
---	--	--	--

2. Vendor Information

Approved Vendor	Vendor Part #	Contact #	Preferred Vendor
1)			



BendPak[®]
PROVIDING AUTOMOTIVE SERVICE SOLUTIONS

Santa Paula, CA USA
www.bendpak.com

MODEL NUMBER

SERIAL NUMBER



PN 5905285

PEEL OFF INVENTORY LABEL

MODEL NUMBER

SERIAL NUMBER

PART SPECIFICATION FORM

BENDPAK Number:	5905285
MRP Description:	SERIALTAG EXTERIOR PEEL OFF INVENTORY LABEL
Date:	03/07/2016
ECO :	00743

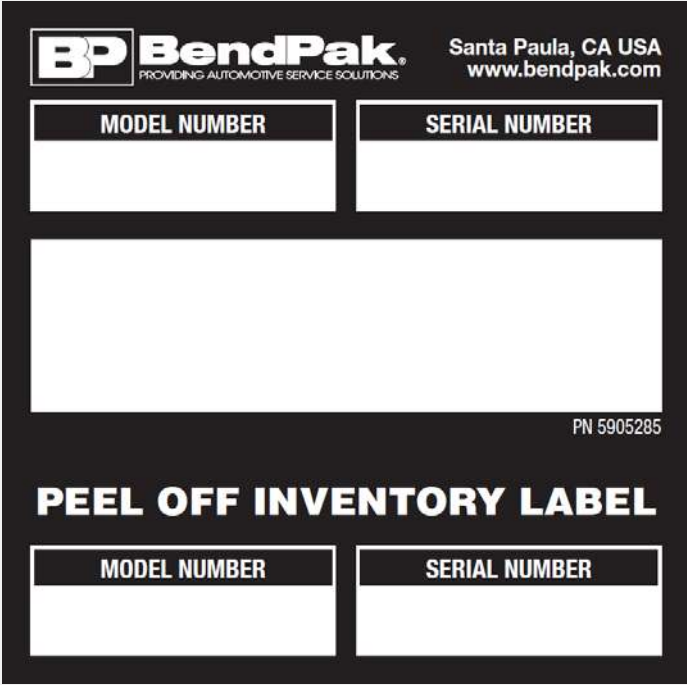
1. Engineering Specification	OBSOLETE REPLACED WITH 5905960
<u>Application:</u> DATA SERIAL TAG	
<u>Detailed Description:</u>	
	<p><u>SIZE:</u> 3" L x 3" W (76mm x 76mm)</p>

2. Vendor Information			
Approved Vendor	Vendor Part #	Contact #	Preferred Vendor
1)			

MFD. BY BENDPAK INC.

LIFT TYPE: SURFACE MOUNT CAPACITY: MED/HVY DTY

POWER: ELECTRIC/HYDRAULIC ANCHORS: AS EQUIPPED

INSTALLATION - SEE OWNERS GUIDE OR CONTACT FACTORY

SHIPPING DAMAGE CLAIMS

WHEN THIS EQUIPMENT IS SHIPPED, TITLE PASSES TO THE PURCHASER UPON RECEIPT FROM THE CARRIER. CONSEQUENTLY, CLAIMS FOR THE MATERIAL DAMAGED IN SHIPMENT MUST BE MADE BY THE PURCHASER AGAINST THE TRANSPORTATION COMPANY AT THE TIME SHIPMENT IS RECEIVED.

PLEASE READ ALL OPERATORS/USERS MANUAL(S) PRIOR TO INSTALLATION AND OPERATION. UNDERSTAND AND COMPREHEND THE FULL CONTENTS OF EACH MANUAL(S) PRIOR TO INSTALLATION AND OPERATION. DELIVER THE MANUAL(S) TO ALL OPERATORS. FAILURE TO OPERATE THIS EQUIPMENT AS DIRECTED MAY CAUSE INJURY OR DEATH.

IMPORTANT NOTE:

BENDPAK LIFTS ARE SUPPLIED WITH CONCRETE FASTENERS MEETING THE CRITERIA AS PRESCRIBED BY ASTM E488 - 96(2003). LIFT BUYERS ARE RESPONSIBLE FOR ANY SPECIAL REGIONAL STRUCTURAL AND/OR SEISMIC ANCHORING REQUIREMENTS SPECIFIED BY ANY OTHER AGENCIES AND/OR CODES SUCH AS THE UNIFORM BUILDING CODE (UBC) AND/OR INTERNATIONAL BUILDING CODE (IBC).



INTERNAL BAR CODE - FOR FACTORY AUDIT ONLY 34086

BPK	STYOT	P20KVR	X18576	HVY DTY/	GVR
					832

THE MANUFACTURE, USE, SALE OR IMPORT OF THIS PRODUCT MAY BE SUBJECT TO ONE OR MORE UNITED STATES PATENTS, OR PENDING APPLICATIONS, OWNED BY BENDPAK, INC.

ENGINEERED BY BENDPAK INC USA

MADE IN CHINA

PART SPECIFICATION FORM

BENDPAK Number:	5905465
MRP Description:	MANUFACTURER LABEL
Date:	05/07/2013
ECO :	00593

1. Engineering Specification

Application:

MANUFACTURER LABEL

Detailed Description:

MFD. BY BENDPAK INC.

LIFT TYPE: SURFACE MOUNT CAPACITY: MED/HVY DTY
 POWER: ELECTRIC/HYDRAULIC ANCHORS: AS EQUIPPED
 INSTALLATION – SEE OWNERS GUIDE OR CONTACT FACTORY

SIZE: 5.125" L x 5.125" W (130mm x 130mm)

SHIPPING DAMAGE CLAIMS

WHEN THIS EQUIPMENT IS SHIPPED, TITLE PASSES TO THE PURCHASER UPON RECEIPT FROM THE CARRIER. CONSEQUENTLY, CLAIMS FOR THE MATERIAL DAMAGED IN SHIPMENT MUST BE MADE BY THE PURCHASER AGAINST THE TRANSPORTATION COMPANY AT THE TIME SHIPMENT IS RECEIVED.

PLEASE READ ALL OPERATORS/USERS MANUAL(S) PRIOR TO INSTALLATION AND OPERATION. UNDERSTAND AND COMPREHEND THE FULL CONTENTS OF EACH MANUAL(S) PRIOR TO INSTALLATION AND OPERATION. DELIVER THE MANUAL(S) TO ALL OPERATORS. FAILURE TO OPERATE THIS EQUIPMENT AS DIRECTED MAY CAUSE INJURY OR DEATH.

IMPORTANT NOTE:

BENDPAK LIFTS ARE SUPPLIED WITH CONCRETE FASTENERS MEETING THE CRITERIA AS PRESCRIBED BY ASTM E488 – 96(2003). LIFT BUYERS ARE RESPONSIBLE FOR ANY SPECIAL REGIONAL STRUCTURAL AND/OR SEISMIC ANCHORING REQUIREMENTS SPECIFIED BY ANY OTHER AGENCIES AND/OR CODES SUCH AS THE UNIFORM BUILDING CODE (UBC) AND/OR INTERNATIONAL BUILDING CODE (IBC).



INTERNAL BAR CODE – FOR FACTORY AUDIT ONLY 34086

BPK	STYOT	P20KVR	X18576	HVY DTY/ GVR 832
-----	-------	--------	--------	---------------------

THE MANUFACTURE, USE, SALE OR IMPORT OF THIS PRODUCT MAY BE SUBJECT TO ONE OR MORE UNITED STATES PATENTS, OR PENDING APPLICATIONS, OWNED BY BENDPAK, INC.

ENGINEERED BY BENDPAK INC USA

MADE IN CHINA

2. Vendor Information

Approved Vendor	Vendor Part #	Contact #	Preferred Vendor
1)			

PART SPECIFICATION FORM

BENDPAK Number:	5905721
MRP Description:	WARNING MAX LIFTING CAP 6000LBS/2722 KG LABEL
Date:	10/24/2014
ECO :	00654

1. Engineering Specification

Application:

LIFT CAPACITY STICKER

Detailed Description:

SIZE: 8" L x 3.75" W (203mm x 95mm)

- Material: White Vinyl Pressure Sensitive Adhesive
- Thickness: 4 Mil
- Ink: U.V. protected CMYK 4/C Process
- Finish: Polished
- Print Process: Offset Lithography - 200 line-screen or 300 p.p.i. for digital
- Lamination: Clear-gloss over-laminate for abrasion, chemical, and ultra violet protection

Maximum Lifting Capacity
6,000 lbs. / 2722 kg
! WARNING !
Maximum Lifting Capacity
6,000 lbs. / 2722 kg

FAILURE TO READ AND UNDERSTAND THE FOLLOWING WARNINGS MAY RESULT IN PERSONAL INJURY AND/OR PROPERTY DAMAGE. KEEP HANDS AND FEET CLEAR FROM MOVING PARTS.

Read and understand entire contents of operation manual and warnings below before operating this equipment.

<ul style="list-style-type: none"> ✓ Never exceed the rated capacity of the lift ✓ Do not operate the lift if any component is found to be defective or worn ✓ Never operate lift with any person or equipment below ✓ Always ensure load is centered and stable prior to operating controls ✓ When lowering the lift pay careful attention that all personnel and objects are kept clear. ✓ Always keep a visual line of site on the lift during operation 	<ul style="list-style-type: none"> ✓ Always stand clear of lift when lowering or raising ✓ Never leave lift in elevated position unless safety lock is engaged in the LOCKED position ✓ Keep all body parts and objects away from pinch points when lift is in motion ✓ Use on level concrete in good condition and free of cracks or other defects ✓ Visually confirm safety lock is properly engaged before working on or near lift
---	--

PN 5905721

2. Vendor Information

Approved Vendor	Vendor Part #	Contact #	Preferred Vendor
1)			

PART SPECIFICATION FORM

BENDPAK Number:	5905940
MRP Description:	PRODUCT DATA LABEL
Date:	05/06/2013
ECO :	00593

1. Engineering Specification

Application:

PRODUCT DATA LABEL

Detailed Description:

	SANTA PAULA, CA USA WWW.BENDPAK.COM
LIFT TYPE: SURFACE MOUNT CAP: MED/HVY DTY MFG. BPK SEE DATA PLATE FOR PRODUCT DETAILS POWER: ELECTRIC/HYDRAULIC INSTALLATION - SEE OWNERS GUIDE OR CONTACT FACTORY	
<p>SAFETY INSTRUCTIONS: IF ATTACHMENTS, ACCESSORIES OR CONFIGURATION MODIFYING COMPONENTS THAT ARE LOCATED IN THE LOAD PATH, AFFECT OPERATION OF THE LIFT, AFFECT THE LIFT ELECTRICAL LISTING OR AFFECT INTENDED VEHICLE ACCOMMODATION ARE USED ON THIS LIFT AND, IF THEY ARE NOT CERTIFIED FOR USE ON THIS LIFT, THEN THE CERTIFICATION OF THIS LIFT SHALL BECOME NULL AND VOID. CONTACT THE PARTICIPANT FOR INFORMATION PERTAINING TO CERTIFIED ATTACHMENTS, ACCESSORIES OR CONFIGURATION MODIFYING COMPONENTS.</p> <p>BENDPAK LIFTS ARE SUPPLIED WITH CONCRETE FASTENERS MEETING THE CRITERIA AS PRESCRIBED BY ASTM E488 - 96(2003). LIFT BUYERS ARE RESPONSIBLE FOR ANY SPECIAL REGIONAL STRUCTURAL AND/OR SEISMIC ANCHORING REQUIREMENTS SPECIFIED BY ANY OTHER AGENCIES AND/OR CODES SUCH AS THE UNIFORM BUILDING CODE (UBC) AND/OR INTERNATIONAL BUILDING CODE (IBC).</p> <p>THE MANUFACTURE, USE, SALE OR IMPORT OF THIS PRODUCT MAY BE SUBJECT TO ONE OR MORE UNITED STATES PATENTS, OR PENDING APPLICATIONS, OWNED BY BENDPAK, INC. DO NOT REMOVE ENGINEERED BY BENDPAK INC. USA MADE IN CHINA</p>	

SIZE: 2.3" L x 4.5" W (58mm x 114mm)

2. Vendor Information

Approved Vendor	Vendor Part #	Contact #	Preferred Vendor
1)			

PART SPECIFICATION FORM

BENDPAK Number:	5905951
MRP Description:	2015_SERIAL_TAG-B-5905951
Date:	07/19/2016
ECO :	00752

1. Engineering Specification



Application:

DATA SERIAL TAG

Detailed Description:

SIZE: 3" L x 3" W (76.2mm x 76.2mm)

Santa Paula, CA USA
www.bendpak.com

MODEL NUMBER	
SERIAL NUMBER	
LIFT CAPACITY	DESCRIPTION
VOLTAGE	
<input type="checkbox"/> 110-240VAC, 50-60 Hz, 1 Ph	<input type="checkbox"/> 380-415VAC, 50-60 Hz, 3 Ph
<input type="checkbox"/> 208-240VAC, 50-60 Hz, 1 Ph	<input type="checkbox"/> 208-440VAC, 50-60 Hz, 3 Ph
DATE OF MFG.	
<div style="display: flex; justify-content: space-between; align-items: center;"> <div style="text-align: center;">  <p>DANGER! Disconnect Power Before Servicing</p> </div> <div style="text-align: center;">  </div> </div> <p style="font-size: x-small; text-align: center;">WARRANTY VOID IF DATA PLATE IS REMOVED PN 5905951</p>	

2. Vendor Information (Or for Reference)

Approved Vendor	Vendor Part #	Contact #	Preferred Vendor
1)			
2)			
OR BENDPAK ENGINEERING APPROVED EQUIVALENT			



Santa Paula, CA USA
www.bendpak.com

MODEL NUMBER

SERIAL NUMBER

LIFT CAPACITY

DESCRIPTION

VOLTAGE

110-240VAC, 50-60 Hz, 1 Ph

380-415VAC, 50-60 Hz, 3 Ph

208-240VAC, 50-60 Hz, 1 Ph

208-440VAC, 50-60 Hz, 3 Ph

DATE OF MFG.



DANGER!

Disconnect Power
Before Servicing

EAC

WARRANTY VOID IF DATA PLATE IS REMOVED PN 5905951

PART SPECIFICATION FORM

BENDPAK Number:	5905970
MRP Description:	LR-60_Packaging_Label
Date:	01/06/2016
ECO :	00736

1. Engineering Specification

Application:

PACKAGING LABEL

Detailed Description:

SIZE: 8" (203mm) W x 3.75" (95mm) H

- Material: White Adhesive Paper
- Ink: U.V. protected CMYK 4/C Process
- Print Process: Offset Lithography - 200 line-screen or 300 p.p.i. for digital



2. Vendor Information (Or for Reference)

Approved Vendor	Vendor Part #	Contact #	Preferred Vendor
1)			
2)			
OR BENDPAK ENGINEERING APPROVED EQUIVALENT			

BP BendPak®

Low-Rise Car Lift

LR-60



6,000 Lb.
CAPACITY

- ✓ Tow handle makes it easy to move lift
- ✓ Multi-position safety locks
- ✓ Heavy-duty steel channel frame
- ✓ Dropped cross bar for added clearance



1645 Lemonwood Drive • Santa Paula, CA 93060 • TEL: 1-805-933-9970 • www.bendpak.com

ENGINEERED BY BENDPAK USA • MADE IN CHINA
PN 5905970

REV	DESCRIPTION	REVISION	DATE	EDITED BY	ECO#
A	PRODUCTION RELEASE		10/28/2015	HG	00736

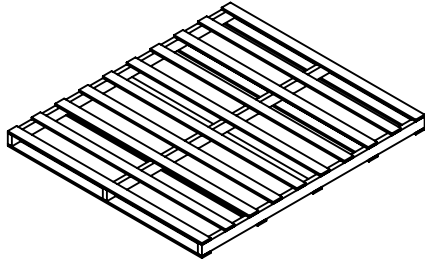

ISOMETRIC VIEW
FOR REFERENCE ONLY
DO NOT SCALE

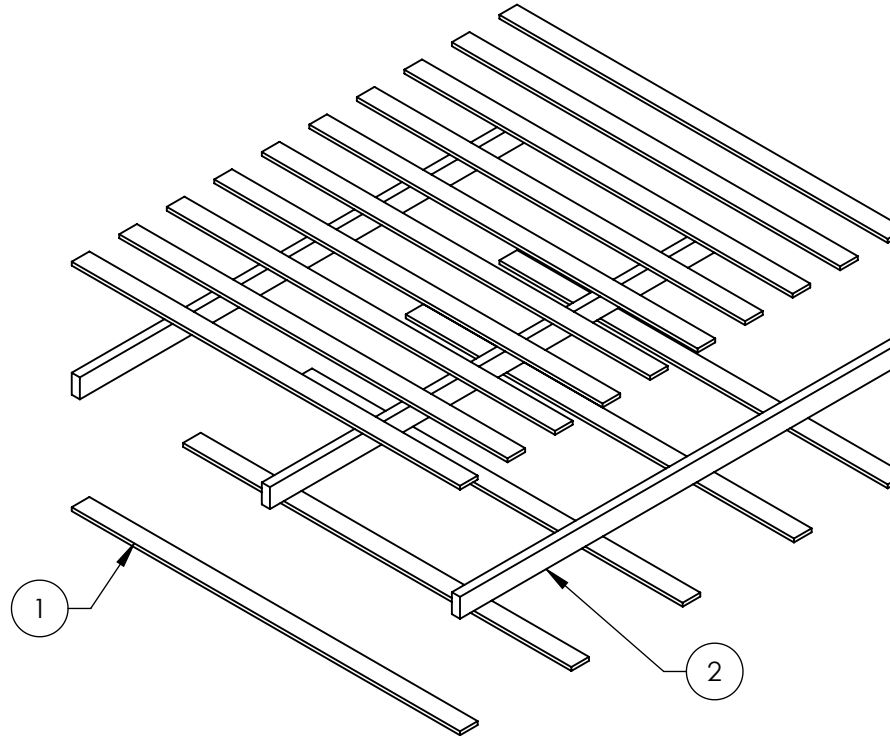

NOTE: UNLESS OTHERWISE SPECIFIED.

1. ASSEMBLE AS SHOWN
2. MATERIAL: HARDWOOD

NEXT ASSEMBLY
5260167
5260168

ITEM NO	PART NUMBER	DESCRIPTION	QTY	REV
1	5940007-1	LR-60/60P SLAT, 1816 x 82.5 x 16mm	15	A
2	5940007-2	LR-60/60P RUNNER, 2083 x 89 x 38mm	3	A

DO NOT SCALE DRAWING	NAME	DATE	1645 LEMONWOOD DR. SANTA PAULA, CA 93060
DIMENSIONS ARE IN MM 	DRAWN	TM 12/31/2015	
	CHECKED	CA 01/08/2016	
THIRD ANGLE PROJECTION			
PROPRIETARY AND CONFIDENTIAL THE INFORMATION CONTAINED IN THIS DRAWING IS THE SOLE PROPERTY OF BENDPAK INC. ANY REPRODUCTION IN PART OR AS A WHOLE WITHOUT THE WRITTEN PERMISSION OF BENDPAK INC. IS PROHIBITED.			TITLE: LR-60/60P PALLET ASSEMBLY
SIZE	DWG. NO.	REV	
A	5940007	A	
SCALE: 1:25			SHEET 1 OF 2

⚠️ WARNING

Read and understand all safety warning and operation procedures before using lift. Keep hands and feet clear from moving parts.

OPERATION INSTRUCTIONS

TO RAISE LIFT:

- Clear area of personnel and make sure lift is in full lowered position.
- Drive vehicle over lift making sure center line of the vehicle is positioned properly over lift pads.
- Position lift pads underneath the vehicle making sure that they make secure contact with the factory recommended lifting points.
- Before raising, make sure the weight of the vehicle does not exceed rated capacity of lift.
- Push the **RAISE** button to commence lifting.
- Raise lift until the vehicles tires clear the floor.
- Stop then check if vehicle is secure and the lifting pads are still in contact with the frame.

- Continue raising vehicle to desired height.
- Raise until the safety lock bars drop into the **LOCKED** position as described on *Fig. A*
- Raise the lift to the desired height then lower the lift until the **LOCK BARS** rests against the **LOCK BLOCK**.

TO LOWER LIFT:

- Clear area before lowering lift.
- Raise the lift until the release cam drops into the **UNLOCKED** position as described on *Fig. B*
- Push the **LOWERING** handle until the lift starts to descend. Stay clear of lift area.
- Fully lower the lift and remove all lifting adapters before driving vehicle away.

⚠️ WARNING

ALWAYS ensure that the safety is in **LOCKED** position before any attempt is made to work on or near the vehicle.

SAFETY IN LOCKED POSITION

(Release cam raised Lock Bar resting against Lock Block)

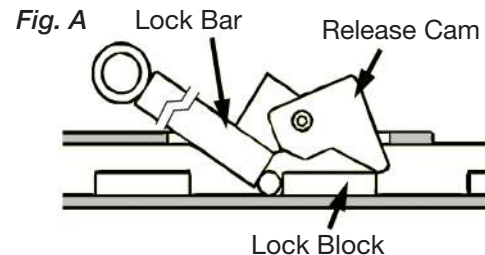

SAFETY IN UNLOCKED POSITION

(Release cam lowered)

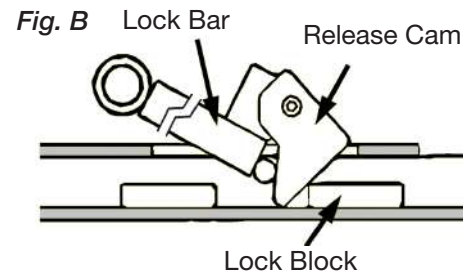

⚠️ WARNING

Drive car completely over lift

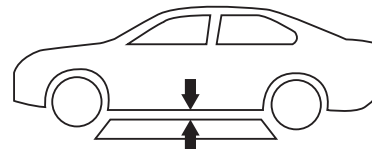

NEVER OVERLOAD LIFT

Check for 1" minimum clearance between car and lift before raising.

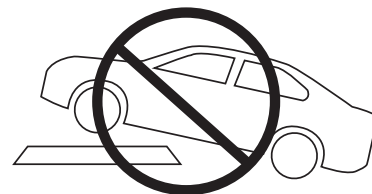

DO NOT park on, or load lift in a fully lowered position or damage may result.

WARNING!

VERY IMPORTANT

**TO PROLONG LIFE EXPECTANCY
OF CYLINDER SEALS AND
PREVENT PREMATURE LEAKAGE
AND WEAR, RAISE LIFT TO FULL
HEIGHT AT LEAST ONCE A DAY.**

**ALSO, THIS IS AN EFFECTIVE
WAY TO BLEED ANY TRAPPED
AIR AND MAINTAIN EQUAL
LIFTING OF THE SYSTEM.**

PN 5905176

Maximum Lifting Capacity
6,000 lbs. / 2722 kg



WARNING!



Maximum Lifting Capacity
6,000 lbs. / 2722 kg

FAILURE TO READ AND UNDERSTAND THE FOLLOWING WARNINGS MAY RESULT IN PERSONAL INJURY AND/OR PROPERTY DAMAGE. KEEP HANDS AND FEET CLEAR FROM MOVING PARTS.

Read and understand entire contents of operation manual and warnings below before operating this equipment.

- ✓ Never exceed the rated capacity of the lift
- ✓ Do not operate the lift if any component is found to be defective or worn
- ✓ Never operate lift with any person or equipment below
- ✓ Always ensure load is centered and stable prior to operating controls
- ✓ When lowering the lift pay careful attention that all personnel and objects are kept clear.
- ✓ Always keep a visual line of site on the lift during operation
- ✓ Always stand clear of lift when lowering or raising
- ✓ Never leave lift in elevated position unless safety lock is engaged in the LOCKED position
- ✓ Keep all body parts and objects away from pinch points when lift is in motion
- ✓ Use on level concrete in good condition and free of cracks or other defects
- ✓ Visually confirm safety lock is properly engaged before working on or near lift

PN 5905721



2016
NON-CE 4 Post Lifts
Colors & Graphics

MODELS:

HD-9SW HDS-40
HD-9SWX HDS-40X
HD-14T HD-9AE

4/7/16

CONFIDENTIAL INFORMATION.

You may not disclose, print, copy or disseminate this information.
Unauthorized use is a violation of federal criminal law.

4 Post Lifts Product Decal Positioning



Total of 4

PN 5905311

BPK Post Branding Decal-Large_5905311.pdf:

Material: Clear Adhesive PET

Size: 4.25"W x 38"H

Thickness: 4 Mil

Finish: Polished

Ink: U.V. protected, Opaque White

Print Process: Silk Screen, 85 line-screen (Yellow color in file represents what should be clear PET material and SHOULD NOT print as Yellow ink. White area in file represents Opaque White ink.)

Lamination: Clear-gloss over-laminate for abrasion, chemical, and ultra violet protection

B

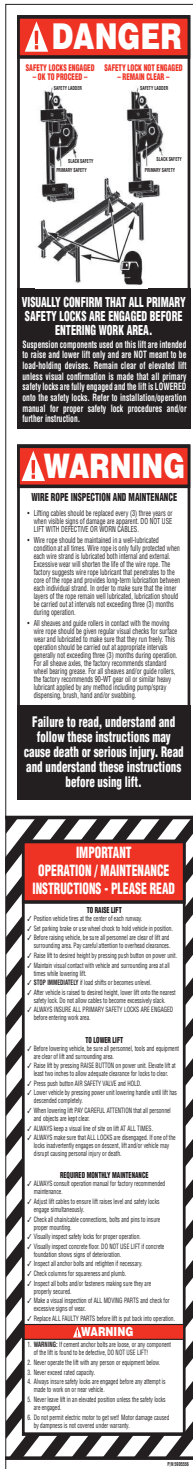

PN 5905556

4_Post_Safety_Decal.pdf:

Size: 4"W x 23"H

Material: White Vinyl Pressure Sensitive Adhesive

Thickness: 4 Mil

Ink: U.V. protected CMYK 2/C Process

Finish: Polished

Print Process: Offset Lithography - 200 line-screen or 300 p.p.i. for digital

Lamination: Clear-gloss over-laminate for abrasion, chemical, and ultra violet protection

C



Ali_4_Post_labels.pdf:

(Order Labels from ALI)

4 Post Lifts Product Decal Positioning

***D**

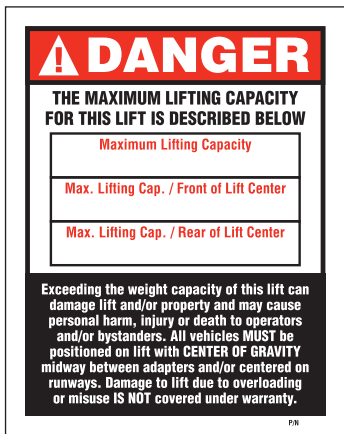

- P/N 5905401 - Max Cap. Danger 7k
- P/N 5905695 - Max. Cap. Danger 7500
- P/N 5905402 - Max Cap. Danger 9k
- P/N 5905557 - Max. Cap. Danger 14K
- P/N 5905406 - Max Cap. Danger 18k
- P/N 5905407 - Max. Cap. Danger 27K
- P/N 5905408 - Max. Cap. Danger 35K
- P/N 5905409 - Max. Cap. Danger 40K

***Max. Cap. Danger.pdf:**

Size: 4"W x 5"H
 Material: White Vinyl Pressure Sensitive Adhesive
 Thickness: 4 Mil
 Ink: U.V. protected CMYK 2/C Process
 Finish: Polished
 Print Process: Offset Lithography - 200 line-screen or 300 p.p.i. for digital
 Lamination: Clear-gloss over-laminate for abrasion, chemical, and ultra violet protection

***E**



- P/N 5905645 - NRTL_Lifting_Cap_Label_7K
- P/N 5905700 - NRTL_Lifting_Cap_Label_7500
- P/N 5905650 - NRTL_Lifting_Cap_Label_9k
- P/N 5905665 - NRTL_Lifting_Cap_Label_14k
- P/N 5905675 - NRTL_Lifting_Cap_Label_18k
- P/N 5905680 - NRTL_Lifting_Cap_Label_27k
- P/N 5905685 - NRTL_Lifting_Cap_Label_35K
- P/N 5905690 - NRTL_Lifting_Cap_Label_40K

***NRTL_Lifting_Cap_Label_.pdf:**

Size: 4.5"W x 3.25"H
 Material: White Vinyl Pressure Sensitive Adhesive
 Thickness: 4 Mil
 Ink: U.V. protected CMYK 2/C Process
 Finish: Polished
 Print Process: Offset Lithography - 200 line-screen or 300 p.p.i. for digital
 Lamination: Clear-gloss over-laminate for abrasion, chemical, and ultra violet protection

***DEPENDS ON LIFT MODEL AND CAPACITY**

F



PN 5905940

Product_Data_Label_5905940-New.pdf:

Size: 4.5"W x 2.3"H
 Material: White Vinyl Pressure Sensitive Adhesive
 Thickness: 4 Mil
 Ink: U.V. protected CMYK 2/C Process
 Finish: Polished
 Print Process: Offset Lithography - 200 line-screen or 300 p.p.i. for digital
 Lamination: Clear-gloss over-laminate for abrasion, chemical, and ultra violet protection

G



PN 5905952

2015_Serial_Tag-C-5905952.jpg:

Size: 3"W x 3"H
 Material: Material: 2 Mil. Matte Silver Polyester (Flex-PSE)
 Print using thermal transfer printer with resin ribbon
 Ink: 1 Color-Black

H



PN 5905326

ALI-Gold-Label-5905326.jpg

****FOR ALI APPROVED LIFTS ONLY**

4 Post Lifts Product Decal Positioning

****FOR ALL APPROVED
LIFTS ONLY**

D, H, G, F

**Front of Post
(Top to Bottom)**

E, C

**Back of Post
(Top to Bottom)**

B

Side of Post

A

(Front & Back of post)

A

(Front & Back of post)

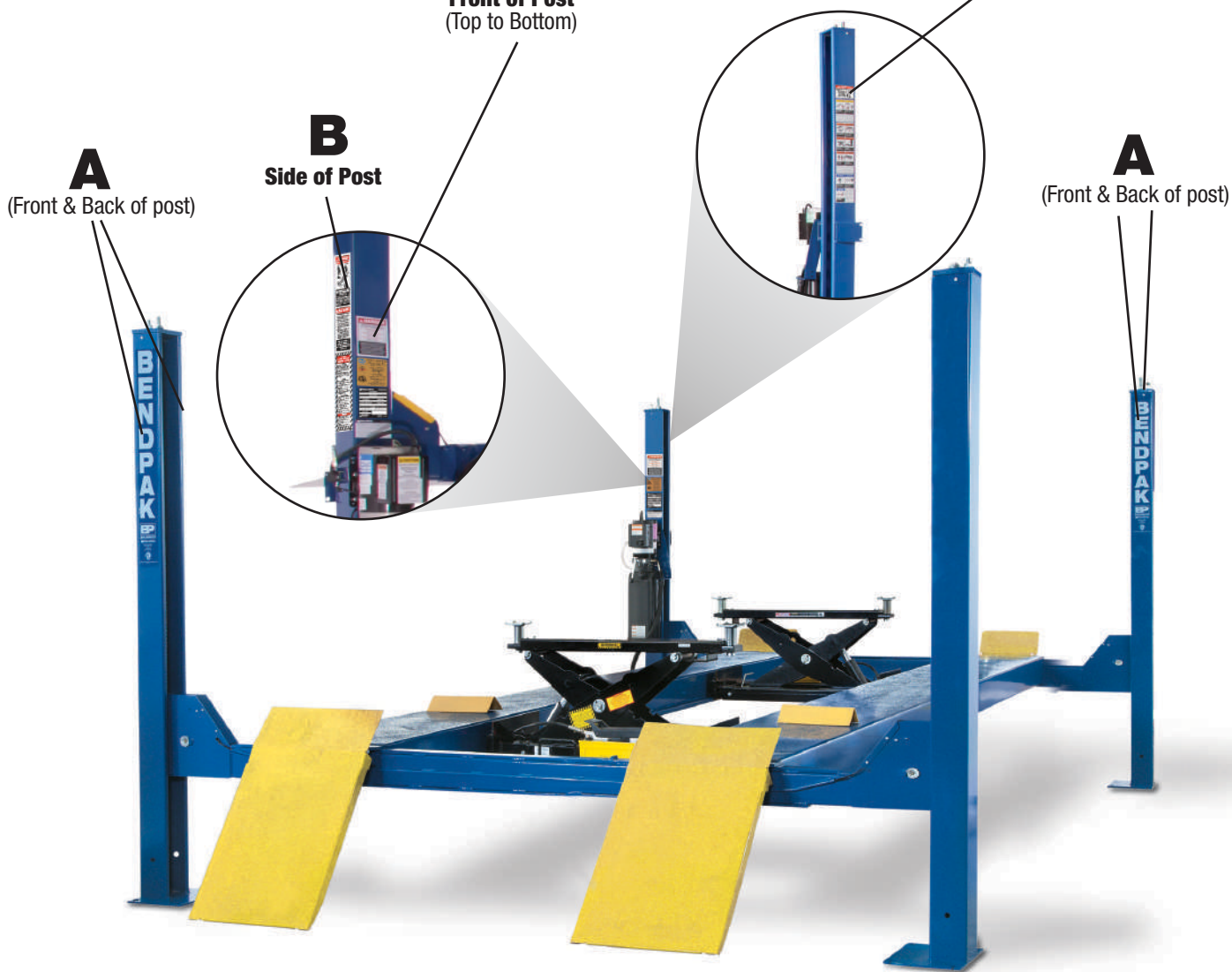

4 Post Lifts Packaging

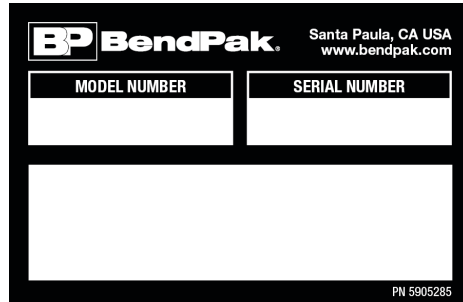

Serial_Tag_New-2015_Peel_Off-5905285.jpg:

Size: 3"W x 3"H

Material: 2 Mil. Matte Silver Polyester (Flex-PSE)

Print using thermal transfer printer with resin ribbon

Ink: 1 Color-Black

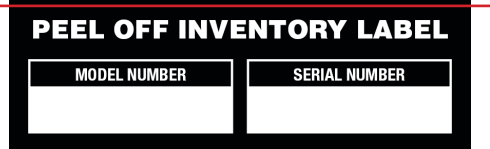

PN 5905285

Do not remove back sheet of this portion to prevent from sticking completely as shown in image.



MFD. BY BENDPAK INC.

LIFT TYPE: SURFACE MOUNT CAPACITY: MED/HVY DTY

POWER: ELECTRIC/HYDRAULIC ANCHORS: AS EQUIPPED

INSTALLATION - SEE OWNERS GUIDE OR CONTACT FACTORY

SHIPPING DAMAGE CLAIMS
WHEN THIS EQUIPMENT IS SHIPPED, TITLE PASSES TO THE PURCHASER UPON RECEIPT FROM THE CARRIER. CONSEQUENTLY, CLAIMS FOR THE MATERIAL DAMAGED IN SHIPMENT MUST BE MADE BY THE PURCHASER AGAINST THE TRANSPORTATION COMPANY AT THE TIME SHIPMENT IS RECEIVED.

PLEASE READ ALL OPERATORS/USERS MANUAL(S) PRIOR TO INSTALLATION AND OPERATION. UNDERSTAND AND COMPREHEND THE FULL CONTENTS OF EACH MANUAL(S) PRIOR TO INSTALLATION AND OPERATION. DELIVER THE MANUAL(S) TO ALL OPERATORS. FAILURE TO OPERATE THIS EQUIPMENT AS DIRECTED MAY CAUSE INJURY OR DEATH.

IMPORTANT NOTE:
BENDPAK LIFTS ARE SUPPLIED WITH CONCRETE FASTENERS MEETING THE CRITERIA AS PRESCRIBED BY ASTM E488 - 96(2003). LIFT BUYERS ARE RESPONSIBLE FOR ANY SPECIAL REGIONAL STRUCTURAL AND/OR SEISMIC ANCHORING REQUIREMENTS SPECIFIED BY ANY OTHER AGENCIES AND/OR CODES SUCH AS THE UNIFORM BUILDING CODE (UBC) AND/OR INTERNATIONAL BUILDING CODE (IBC).



INTERNAL BAR CODE - FOR FACTORY AUDIT ONLY 34086

BPK | STYOT | P20KVR | X18576 | HVY DTY/ GVR
832

THE MANUFACTURE, USE, SALE OR IMPORT OF THIS PRODUCT MAY BE SUBJECT TO ONE OR MORE UNITED STATES PATENTS, OR PENDING APPLICATIONS, OWNED BY BENDPAK, INC.

ENGINEERED BY BENDPAK INC USA

MADE IN CHINA

Manufacturer Packaging Label:

Size: 5"W x 5"H

Material: White adhesive paper

Ink: U.V. protected CMYK 2/C Process

Print Process: Offset Lithography - 200 line-screen or 300 p.p.i. for digital