

Low-Rise Scissor Lift Installation and Operation Manual

Manual P/N 5900337 — Manual Revision F — December 2020

Models:

- LR-60
- LR-60P



LR-60 shown.

Designed and engineered by BendPak Inc. in Southern California, USA. Made in China.

 **DANGER**

Read the *entire contents* of this manual *before* using this product. Failure to follow the instructions and safety precautions in this manual can result in serious injury or death. Make sure all other operators also read this manual. Keep the manual near the product for future reference. *By proceeding with setup and operation, you agree that you fully understand the contents of this manual and assume full responsibility for product use.*

Manual. LR-60/60P Low-Rise Scissor Lift, *Installation and Operation Manual*, Manual Part Number 5900337, Manual Revision F, released December 2020.

Copyright. Copyright © 2020 by BendPak Inc. All rights reserved. You may make copies of this document if you agree that: you will give full attribution to BendPak Inc., you will not make changes to the content, you do not gain any rights to this content, and you will not use the copies for commercial purposes. By making copies of this document, you are agreeing to abide by these terms.

Trademarks. BendPak and the BendPak logo are registered trademarks of BendPak Inc. All other company, product, and service names are used for identification only. All trademarks and registered trademarks mentioned in this manual are the property of their respective owners.

Limitations. Every effort has been made to ensure complete and accurate instructions are included in this manual. However, product updates, revisions, and/or changes may have occurred since this manual was published. BendPak reserves the right to change any information in this manual without incurring any obligation for equipment previously or subsequently sold. BendPak is not responsible for typographical errors in this manual. You can always find the latest version of the **manual for your product on the BendPak website**.

Warranty. The BendPak warranty is more than a commitment to you: it is also a commitment to the value of your new product. Contact your nearest BendPak dealer or visit www.bendpak.com/support/warranty for full warranty details. Go to bendpak.com/support/register-your-product/ and fill out the online form to register your product (be sure to click **Submit**).

Safety. Your product was designed and manufactured with safety in mind. However, your safety also depends on proper training and thoughtful operation. Do not install, operate, maintain, or repair the unit without reading and understanding this manual and the labels on the unit; **do not use your Lift unless you can do so safely!**

Owner Responsibility. In order to ensure operator safety and maintain your product properly, it is the responsibility of the product owner to read and follow these instructions:

- Follow all setup, operation, and maintenance instructions.
- Make sure product setup and use conforms to all applicable local, state, and federal codes, rules, and regulations, such as state and federal OSHA regulations and electrical codes.
- Read and follow all safety instructions. Keep them readily available for operators.
- Make sure all operators are properly trained, know how to safely operate the unit, and are properly supervised.
- Do not operate the product until you are certain all parts are in place and operating correctly.
- Carefully inspect the product on a regular basis and perform all maintenance as specified.
- Service and maintain the unit only with approved replacement parts.
- Keep all instructions permanently with the product and make sure all labels are clean and visible.
- **Only use the Lift if it can be used safely!**

Unit Information. Enter the Model Number, Serial Number, and the Date of Manufacture from the label on your unit. This information is required for part or warranty issues.

Model: _____

Serial: _____

Date of Manufacture: _____

| | |
|--|----------------------|
| BP BendPak Santa Paula, CA USA www.bendpak.com | |
| MODEL NUMBER | |
| DESCRIPTION | |
| LIFT CAPACITY | DATE OF MFG. |
| VOLTAGE | SERIAL NUMBER |
| <input type="checkbox"/> 110-240V, 50-60 Hz, 1 Ph | |
| <input type="checkbox"/> 208-240V, 50-60 Hz, 1 Ph | |
| <input type="checkbox"/> 380-415V, 50-60 Hz, 3 Ph | |
| <input type="checkbox"/> 208-440V, 50-60 Hz, 3 Ph | |
| | UPC |
| DANGER! Disconnect Power Before Servicing | |
| WARRANTY VOID IF DATA PLATE IS REMOVED PN 5905951 | |
| ERC | |

Table of Contents

| | | | |
|-------------------------------------|-----------|------------------------------|-----------|
| Introduction | 3 | Operation | 29 |
| Shipping Information | 4 | Maintenance | 35 |
| Safety Considerations | 4 | Troubleshooting | 36 |
| Components | 6 | Wiring Diagram | 37 |
| FAQs | 7 | Labels | 38 |
| Specifications | 8 | Parts Diagrams | 40 |
| Installation Checklist | 9 | ALI Store | 43 |
| Installation | 10 | | |

Introduction

This Manual describes the following lifts:

- **LR-60.** Low-rise, frame-engaging scissor Lift that supports Vehicles up to 6,000 lbs (2,722 kg).
- **LR-60P.** Low-rise, *portable*, frame-engaging scissor Lift that supports Vehicles up to 6,000 lbs (2,722 kg).

More information about the full line of BendPak products is available at bendpak.com.

This manual is mandatory reading for all LR-60/60P users, including anyone who sets up, operates, maintains, or repairs them.

⚠ DANGER Be very careful when setting up, operating, maintaining, or repairing this equipment; failure to do so could result in property damage, product damage, injury, or (in very rare cases) death. Make sure only authorized personnel operate this equipment. All repairs must be performed by an authorized technician. Do not make modifications to the unit; this voids the warranty and increases the chances of injury or property damage. Make sure to read and follow the instructions on the labels on the unit.

Keep this manual on or near the equipment so that anyone who uses or services it can read it.

If you are having issues, refer to the **Troubleshooting** section of this manual for assistance.

Technical support and service is available from your dealer, on the Web at bendpak.com/support, by email at support@bendpak.com, or by phone at **(800) 253-2363**, extension 196.

You may also contact BendPak for parts replacement information (please have the model and serial number of your unit available) at **(800) 253-2363**, extension 191.

Shipping Information

Your equipment was carefully checked before shipping. Nevertheless, you should thoroughly inspect the shipment **before** you sign to acknowledge that you received it.

When you sign the bill of lading, it tells the carrier that the items on the invoice were received in good condition. **Do not sign the bill of lading until after you have inspected the shipment.** If any of the items listed on the bill of lading are missing or damaged, do not accept the shipment until the carrier makes a notation on the bill of lading that lists the missing and/or damaged goods.

If you discover missing or damaged goods **after** you receive the shipment and have signed the bill of lading, notify the carrier at once and request the carrier to make an inspection. If the carrier will not make an inspection, prepare a signed statement to the effect that you have notified the carrier (on a specific date) and that the carrier has failed to comply with your request.

It is difficult to collect for loss or damage after you have given the carrier a signed bill of lading. If this happens to you, file a claim with the carrier promptly. Support your claim with copies of the bill of lading, freight bill, invoice, and photographs. Our willingness to assist in helping you process your claim does not make us responsible for collection of claims or replacement of lost or damaged materials.

Safety Considerations

Read this entire manual carefully before using your new product. Do not set up or use the product until you are familiar with all operating instructions and warnings. Do not allow anyone else to operate the product until they are also familiar with all operating instructions and warnings.

General Safety Information

- The product is a low-rise scissor Lift. Use it only for its intended purpose. Do not make any modifications to the product.
- The product **must** only be operated by authorized, trained, properly supervised personnel.
- When the Lift is being used, only the Operator may be within 30 feet of the unit.
- You **must** wear OSHA-approved (publication 3151) Personal Protective Equipment at all times when installing, using, maintaining, or repairing the Lift. Leather gloves, steel-toed work boots, eye protection, back belts, and hearing protection **are mandatory.**
- Do not use the product while tired or under the influence of drugs, alcohol, or medication.
- Keep loads centered and balanced on the Platforms.
- When the product is in use, keep all body parts away from it.
- Make sure all Operators study and understand the *Installation and Operation Manual*. Keep the Manual near the device at all times.
- Do not use the product in the presence of cigarette smoke, dust, or flammable liquids or gases. Use the product indoors in a well-ventilated area.
- Do not make any modifications to the product; this voids the warranty and increases the chances of injury or property damage. **Do not modify or override safety features.**
- Make a visual inspection of the product before using it each time. Check for damage or missing parts. Do not use the product if you find any issues. Instead, take it out of service, then contact your dealer, email support@bendpak.com, visit bendpak.com/support, or call **(800) 253-2363**.

-
- Make a thorough inspection of the product at least once a year. Replace any damaged or severely worn parts, decals, or warning labels.
 - BendPak recommends referring to the ANSI/ALI ALIS Standard (R2015) *Safety Requirements for Installation and Service* for more information about safely installing, using, and servicing your Lift.

Symbols

Following are the symbols that may be used in this manual:

 **DANGER** Calls attention to an immediate hazard that **will** result in injury or death.

 **WARNING** Calls attention to a hazard or unsafe practice that **could** result in injury or death.

 **CAUTION** Calls attention to a hazard or unsafe practice that could result in minor personal injury, product, or property damage.

NOTICE Calls attention to a situation that, if not avoided, could result in product or property damage.



Tip

Calls attention to information that can help you use your product better.

Liability Information

BendPak Inc. assumes **no** liability for damages resulting from:

- Use of the product for purposes other than those described in this manual.
- Modifications to the equipment without prior, written permission from BendPak Inc.
- Injury or death caused by modifying, disabling, overriding, or removing safety features.
- Damage to the equipment from external influences.
- Incorrect operation of the equipment.

Components

Lift components include:

- **Power Unit.** Provides Hydraulic Fluid to the Hydraulic Cylinders, which raises the Platforms.
- **Platforms.** Flat steel plates that raise and lower. The Lift Pads, which sit on the Platforms, make contact with the underside of the Vehicle.
- **Power Unit Stand.** LR-60 only. Holds the Power Unit. Bolts to the ground.
- **Portable Stand.** LR-60P only. Holds the Power Unit. Freestanding, moveable.
- **Fixed Ramps.** Allows Vehicles to drive on to and off of the Platforms.
- **Hinged Ramps.** Allows Vehicles to drive on to and off of the Platforms. Hinge up when the Platforms are raised. Located opposite the Fixed Ramps.
- **Base.** The bottom of the Lift. Has the holes for the Anchor Bolts for the LR-60.
- **Hydraulic Cylinder.** Pushes the Platforms up to raise a Vehicle, down to lower a Vehicle.
- **Hydraulic Hose.** Moves the Hydraulic Fluid from the Power Unit to the Hydraulic Cylinder.
- **Safety Locks.** Hold the Platforms up, once **engaged**. Always leave the Lift either engaged on a Safety Lock or lowered to the ground.
- **Lift Pads.** Rubber blocks that make contact with the manufacturer-recommended Lifting Points on the underside of the Vehicle being raised.
- **Wheel Assemblies.** LR-60P only. Raises the Hinged Ramp end of the Lift off the ground, allowing the Lift to move to a different location.
- **Tow Cart.** LR-60P only. Used to move the LR-60P to a different location.
- **LR-4A Arm Kit.** *Optional accessory.* Extends the lifting point widths the Lift can support. [Visit the BendPak website](#) for more information.

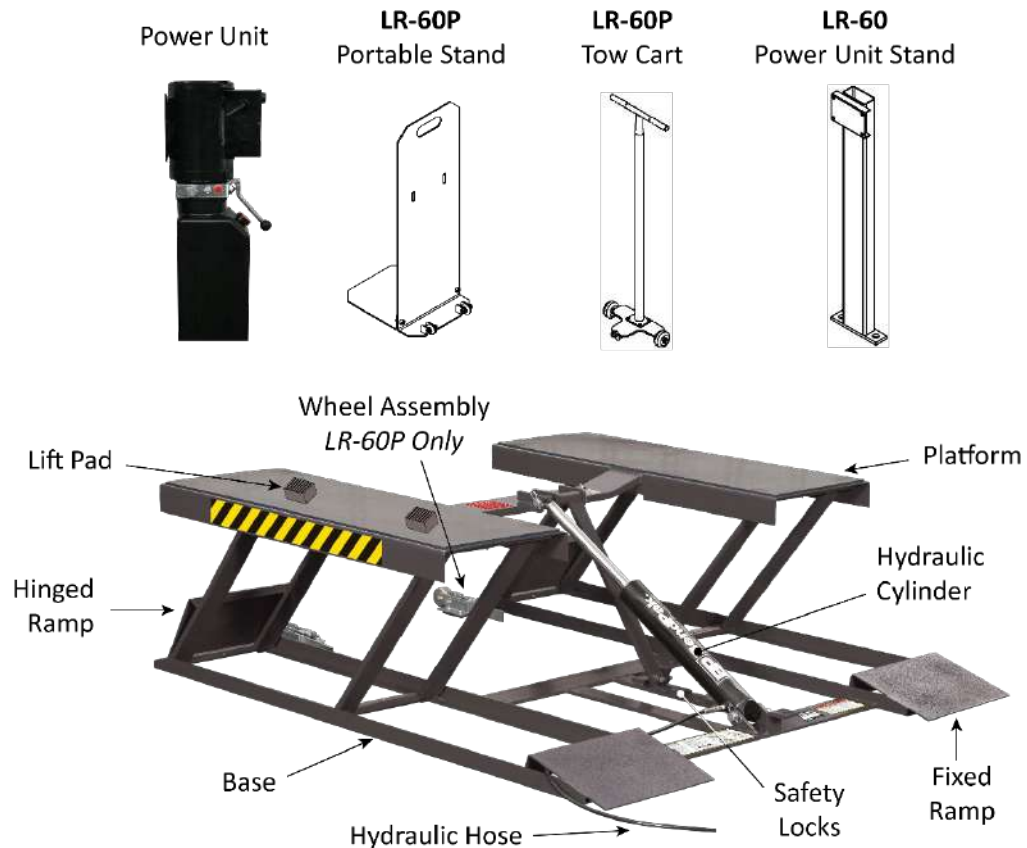

Frequently Asked Questions

Question: How much weight can the LR-60/60P raise?

Answer: The LR-60/60P can raise Vehicles up to 6,000 pounds (2,722 kg).

Q: What if I want to raise a Vehicle that is slightly over the weight capacity of the Lift?

A: **Do not do this!** This is **not** an intended use of the product; you could damage the Lift and injure bystanders. You must **not** raise a Vehicle that is heavier than the rated capacity of the Lift.

Q: How far off the ground will the LR-60/60P raise my Vehicle?

A: It depends. The tops of the Lift Pads, when the Lift is raised, are 27 inches off the ground. But you have to subtract the distance between the top of the Lift Pads and the Lifting Points of the Vehicle being raised, as well as the distance back down to engage on the top Safety Lock. 22 to 24 inches off the ground on the top Safety Lock is a pretty fair estimate for a wide range of Vehicles.

Q: Can the LR-60/60P be installed outside?

A: No. The LR-60 is approved for indoor installation and use only. **Outdoor installation is prohibited.** The reason is to keep the Lift away from moisture, which can cause the Power Unit to stop working.

Q: Can I put the Power Unit on either side of the Lift?

A: Yes. The Power Unit can be located on either side, as far away as the Hose allows.

Q: Which end of the Lift is the “front”?

A: Neither. You can drive onto the Lift from either direction; there are ramps on both ends.

Q: The Lift is described as “frame-engaging”, what does that mean?

A: It means the Lift Pads on the Platforms contact the underside of the Vehicle to raise it, leaving the Wheels hanging freely. Put another way, the Vehicle is **not** raised on its Wheels.

Q: Anything else I should be aware of?

A: One thing. Do not remove all four of a Vehicle’s tires while it is on the Lift and then lower the Vehicle all the way to the ground. It will go down, but it will have a hard time coming back up again. The Lift requires some space to build up enough upward force to raise a Vehicle.

Specifications

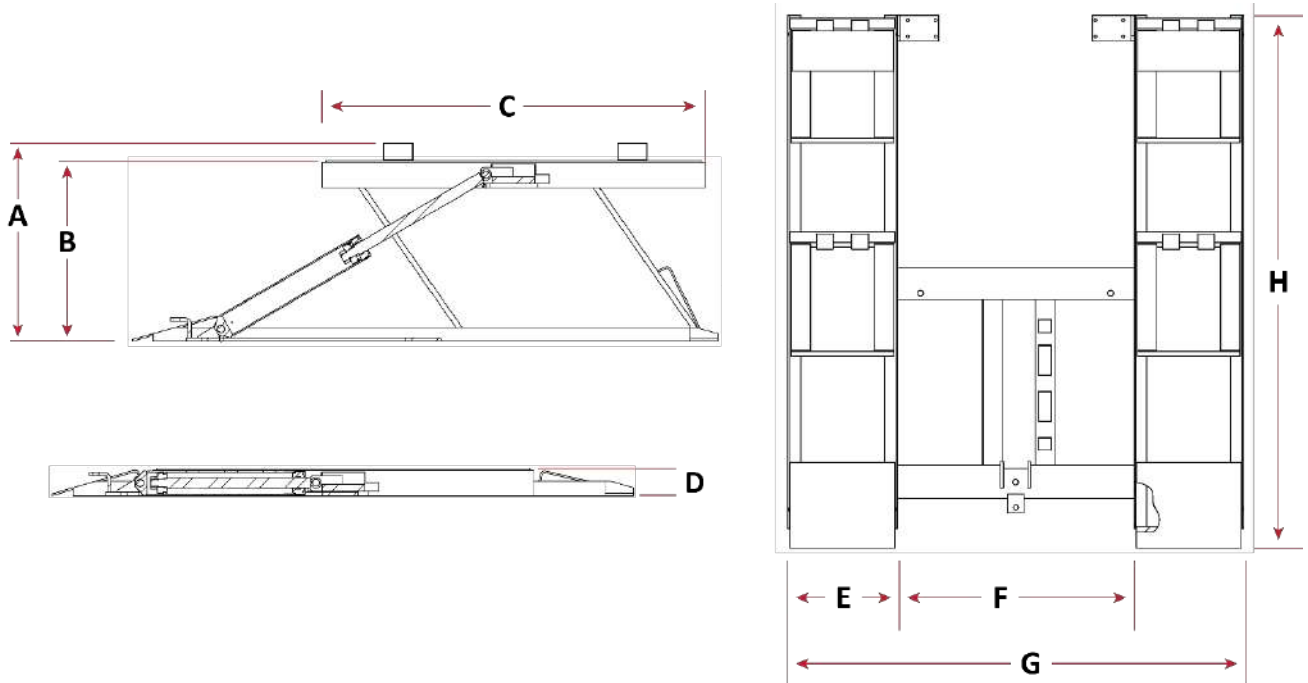

| Model | LR-60 | LR-60P |
|----------------------------------|--------------------------|----------|
| Lifting capacity | 6,000 lbs. / 2,722 kg | |
| Lift style | Fixed | Portable |
| A Lift height w/lift pad | 27" / 689 mm | |
| B Lift height, platform | 25" / 634 mm | |
| C Platform length | 53" / 1,346 mm | |
| D Lowered height | 3.75" / 95 mm | |
| E Platform width | 16.75" / 425 mm | |
| F Width between platforms | 36" / 914 mm | |
| G Overall width | 69.5" / 1,764 mm | |
| H Overall length | 81" / 2,054 mm | |
| Sound, during operation | <70 dB | |
| Lifting time | ~35 seconds | |
| Power Unit | 115 VAC*, 50/60 Hz, 1 Ph | |

* Power Unit comes configured for 115 VAC; is reconfigurable to 230 VAC.

Specifications subject to change without notice.

Installation Checklist

Following are the steps needed to install your Lift. Perform them in the order shown.

- 1. Review the installation Safety Rules.
- 2. Make sure you have the necessary Tools.
- 3. Select the Installation Site.
- 4. Understand Longitudinal Shift.
- 5. Check clearances.
- 6. Unpack and locate the Lift.
- 7. Assemble the Portable Stand (LR-60**P** only).
- 8. Attach the Power Unit to the Portable Stand (LR-60**P** only).
- 9. Assemble the Tow Cart (LR-60**P** only).
- 10. Raise the Platforms Off the Base (LR-60 only).
- 11. About Embedment (LR-60 only).
- 12. Anchor the Bases (LR-60 only).
- 13. Anchor the Power Unit Stand (LR-60 only).
- 14. Install the Wheels (LR-60**P** only).
- 15. Understand Hydraulic Fluid Contamination.
- 16. About Thread Sealants.
- 17. Connect the Hydraulic Hose.
- 18. Add Hydraulic Fluid.
- 19. Reconfigure the Power Unit to 230 VAC Power (optional).
- 20. Connect to Power.
- 21. Test the Lift.
- 22. Review the Final Checklist.

Installation

This section describes how to install your LR-60/60P. Perform the steps in the order listed.

Some installation steps are the same for both Lift models, but some are different.

 **WARNING** *Only use the factory-supplied parts that came with your Lift.* If you use parts from a different source, you void your warranty and compromise the safety of everyone who installs or uses the Lift. If you are missing parts, visit bendpak.com/support or call **(800) 253-2363**, extension 191.

Safety Rules

When installing the Lift, your safety depends on proper training and thoughtful operation.

 **WARNING** Do not install this equipment unless you have automotive Lift installation training. Always use proper tools, such as a Forklift or Shop Crane, to move heavy components. Do not install this equipment without reading and understanding this Manual and the safety labels on the unit.

BendPak recommends referring to the ANSI/ALI ALIS Standard (R2015) *Safety Requirements for Installation and Service* for more information about safely installing, using, and servicing your Lift.

Only trained, supervised personnel should be involved in installing this equipment. ***Pay attention at all times.*** Use appropriate tools and equipment. Stay clear of moving parts.

 **WARNING** You ***must*** wear OSHA-approved (publication 3151) Personal Protective Equipment at all times when installing the Lift. Leather gloves, steel-toed work boots, eye protection, back belts, and hearing protection ***are mandatory.***

Tools

You may need some or all of the following tools:

- Hammer, mallet, crowbar, or pry bar
- Hex key and wrench set, metric and SAE
- Screwdriver set, slot and Phillips
- Level, tape measure
- Adjustable crescent wrench
- Utility knife, tin or sheet metal snips
- Screwdriver set, slot and Phillips
- Forklift or Shop Crane
- Rotary hammer drill, masonry bits

Select a Site

Keep the following in mind when selecting a site for your Lift:

- **Enough space.** Make sure there is adequate space on all sides, plus enough space **above** for the Vehicles you will be raising. *Do not install the Lift under low-hanging obstructions.* See **Check Clearances** for more information.
- **Power Unit Location.** The LR-60 Power Unit Stand can be installed on either side of the Lift, close enough for the Hydraulic Hose to reach. The LR-60**P** Power Unit is installed on a Portable Stand, which can be easily moved to the desired location on either side of the Lift within reach of the Hydraulic Hose. ***Operators must always have a full, unobstructed view of the Lift.***
- **Hose Cover.** The LR-60 comes with a Hose Cover that you can anchor to the ground; it is 54 in / 1,372 mm long. If you plan to use the Hose Cover, make sure to leave enough room between the Power Unit and the Lift.
- **Operator.** The operator ***must*** have a full, unobstructed view of the Lift and the Vehicle on it when raising and lowering Vehicles.
- **Longitudinal Shift.** When you raise the Lift, the geometry of the scissor arms moves the Platforms up at an angle. The amount of longitudinal shift for the LR-60/60P is approximately 14 inches. Refer to **About Longitudinal Shift** for more information.
- **Check for overhead obstructions.** The site must be free of overhead obstructions.
- **Floor.** Do not install or use this Lift on any asphalt surface other than concrete.
- **Concrete specifications.** Do not install the Lift on or within 6 in / 152 mm of expansion seams or cracked or defective concrete. Make sure the concrete is at least 4.25 inches thick, 3,000 psi, and cured for at least 28 days (if newly poured). Make sure the floor is defect-free, dry, and level.

 **WARNING** Do not install the Lift on a surface with 3° of slope or more. A 3° degree or greater slope makes the Lift less secure, possibly causing Vehicles to fall, which could lead to property damage, personal injury, or even death.

- **Power.** You will need a 115 VAC or a 230 VAC power source available near the Power Unit. The Power Unit ships configured for 115 VAC, but it can be reconfigured to operate on 230 VAC (requires an Electrician). Refer to **Connecting to 230 VAC Power** for more information.
- **Operating temperature.** The Lift is designed to be used between temperatures of 41° to 104°F (5° to 40°C).
- **Outdoor installation.** The Lift ***cannot*** be installed outside. It is for indoor use only. If you have the LR-60P, you can move it outside and use it outside temporarily; make sure to keep it completely moisture free while it is outside.
- **Second floor installs.** Do not install the Lift on a second floor or elevated floor without first consulting the building architect and getting their permission.
- **Dress properly.** Always wear protective gear when installing the Lift. Leather gloves, steel-toed work boots, eye protection, back belts, and hearing protection ***are mandatory***. Do ***not*** wear loose clothing or jewelry; contain long hair; keep hair, clothing, and gloves away from moving parts.

 **WARNING** You ***must*** wear OSHA-approved (publication 3151) Personal Protective Equipment ***at all times when installing*** the Lift.

About Longitudinal Shift

When you raise a Vehicle on the LR-60/60P, the Vehicle goes up; it does **not** go straight up.

Instead, the geometry of the scissor arms moves the Platforms up at an angle (called longitudinal shift), towards the Hinged Ramp end of the Lift. The amount of longitudinal shift for the LR-60 and the LR-60P is approximately 14 in / 356 mm.

Longitudinal shift is always in the same direction, towards the Hinged Ramp end of the Lift, no matter which way the Vehicle is facing.

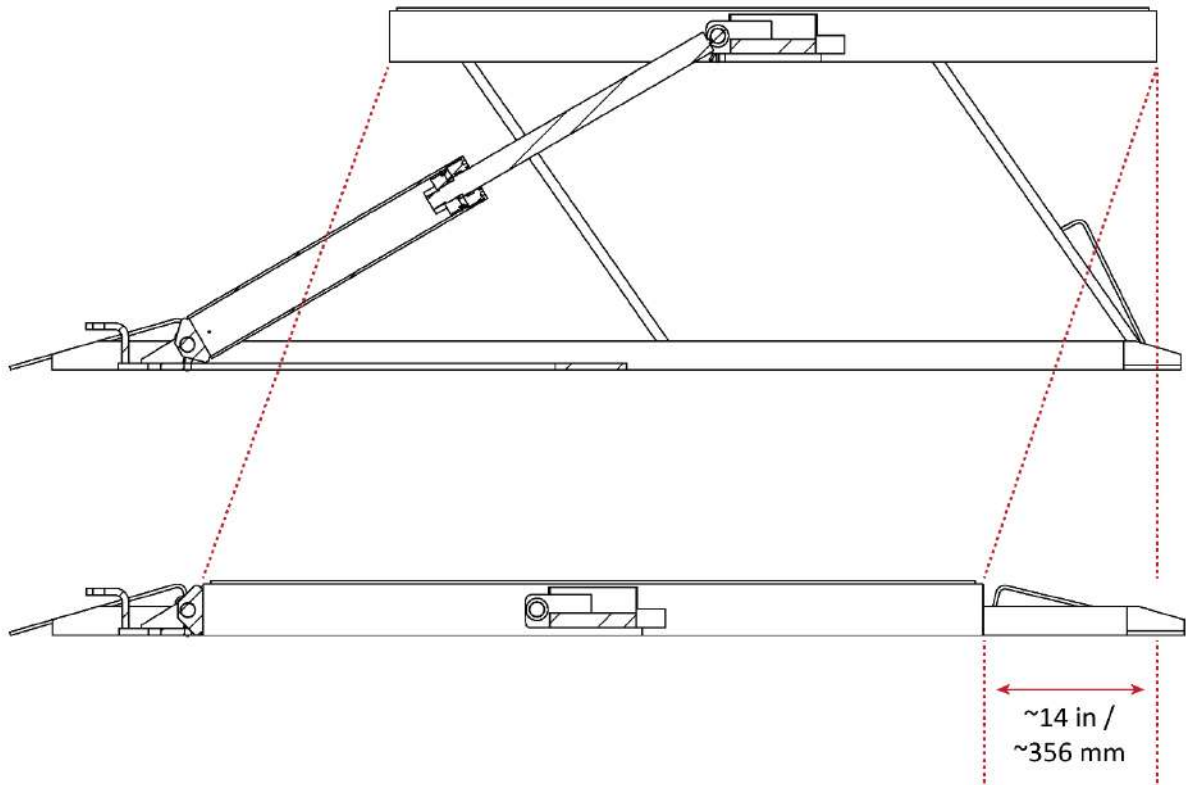

Vehicle not shown. Not necessarily to scale. Not all components shown.

Why is this important? It tells you that you need extra room on the Hinged Ramp end of the Lift to accommodate the longitudinal shift, something you need to consider before choosing a permanent location for the Lift.

Check Clearances

For safety purposes, a certain amount of clear space around the Lift is **required**.

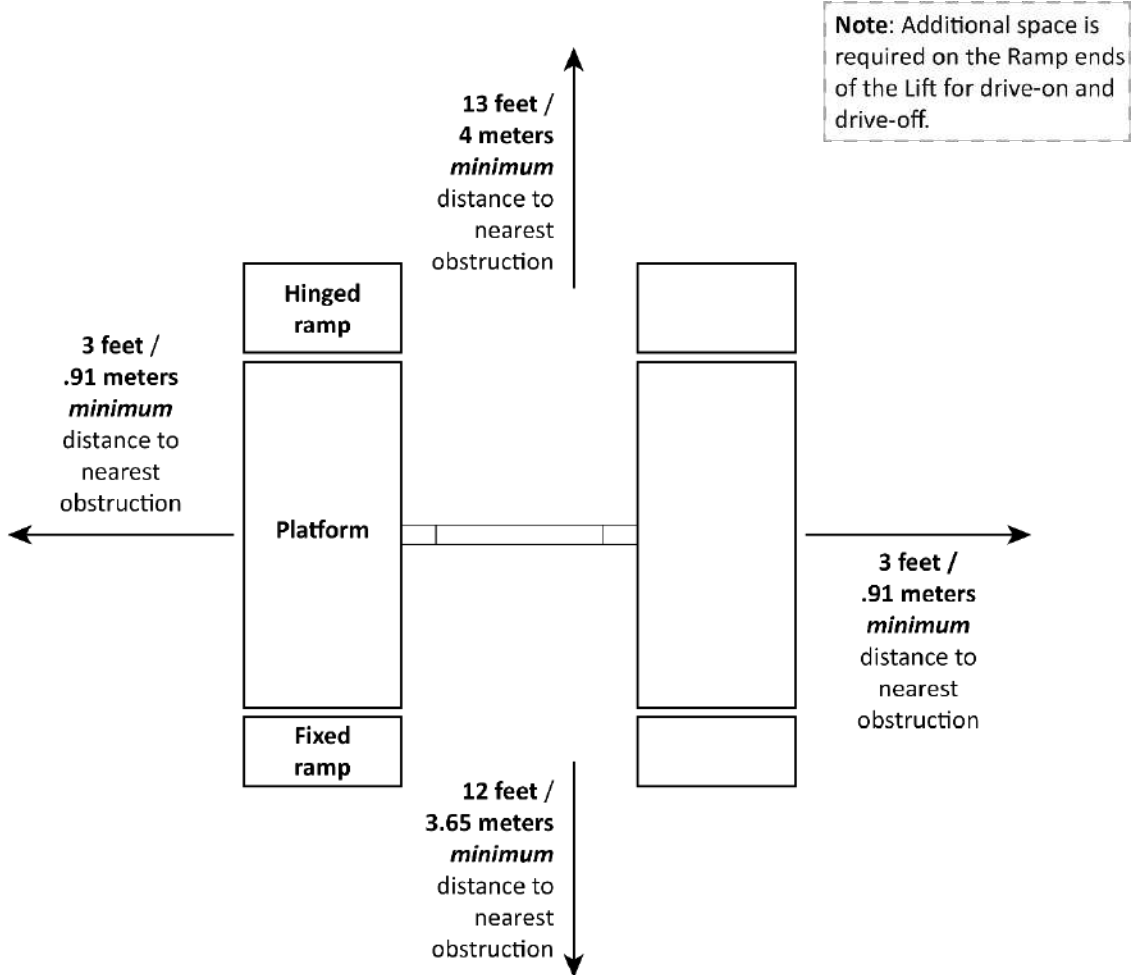

Additional space on Hinged Ramp side for longitudinal shift. Not necessarily to scale. Not all components shown.

Unpack and Locate the Lift

Using an appropriate lifting device (Shop Crane or Forklift, for example), move the Lift off of the bottom of the shipping container and to its permanent location (in the case of the LR-60) or its starting location (in the case of the LR-60P).

CAUTION

Use caution when taking the Lift out of its shipping container. You do not want to damage the unit, misplace the components, or get hurt.



Assemble the Portable Stand (LR-60P only)

The LR-60P comes with a Portable Stand to hold the supplied Power Unit.

Assemble the Portable Stand as shown below; securely tighten all connections.

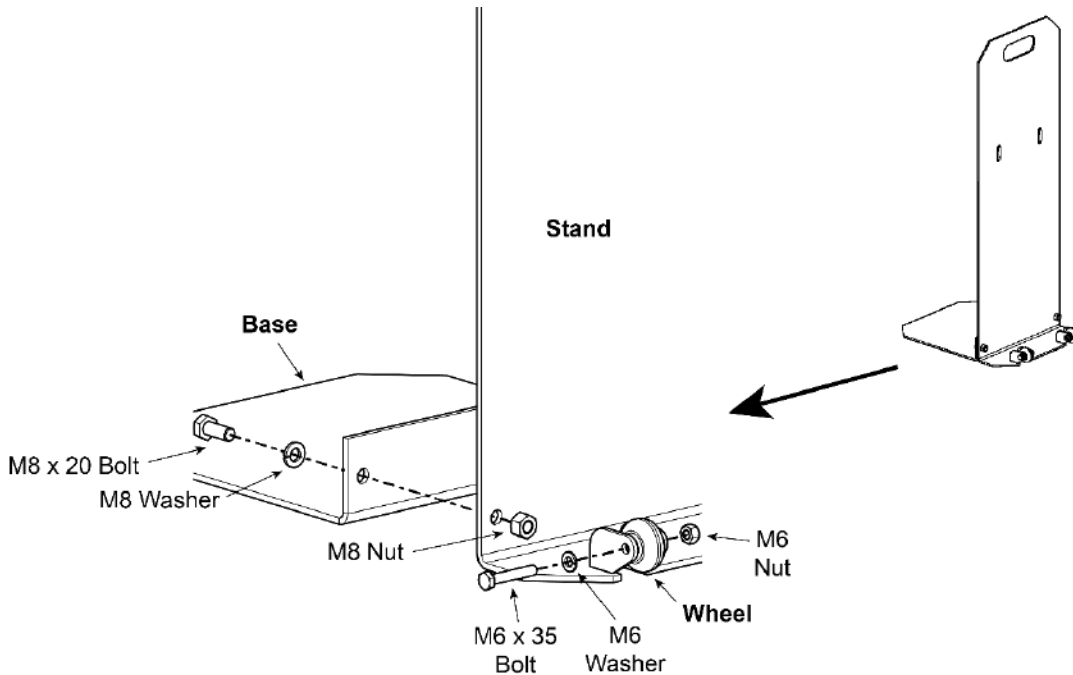

Attach the Power Unit to the Portable Stand

Once you have assembled the Portable Stand, attach the Power Unit.

Attach the Power Unit using the included M8 x 25 Bolts, M10 Washers, and M8 Nuts.

Important: Do not connect the Power Unit to the Hydraulic System or power source at this point of the installation; those connections will be made later.

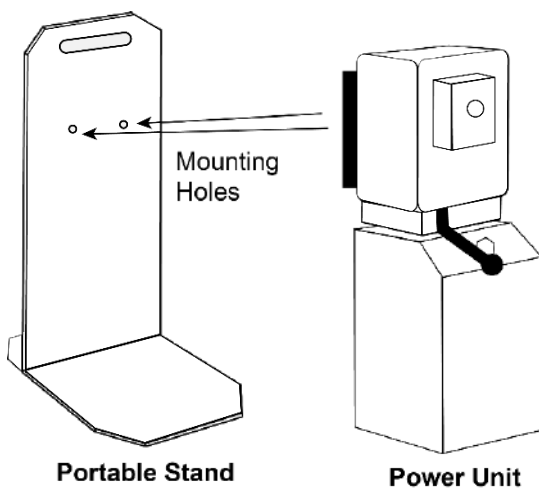

Not drawn to scale. Not all components shown.

Assemble the Tow Cart (LR-60P only)

The Tow Handle, which is used only with the LR-60P, lets you move the Lift to other locations. The following drawing shows how to set up the Tow Cart.

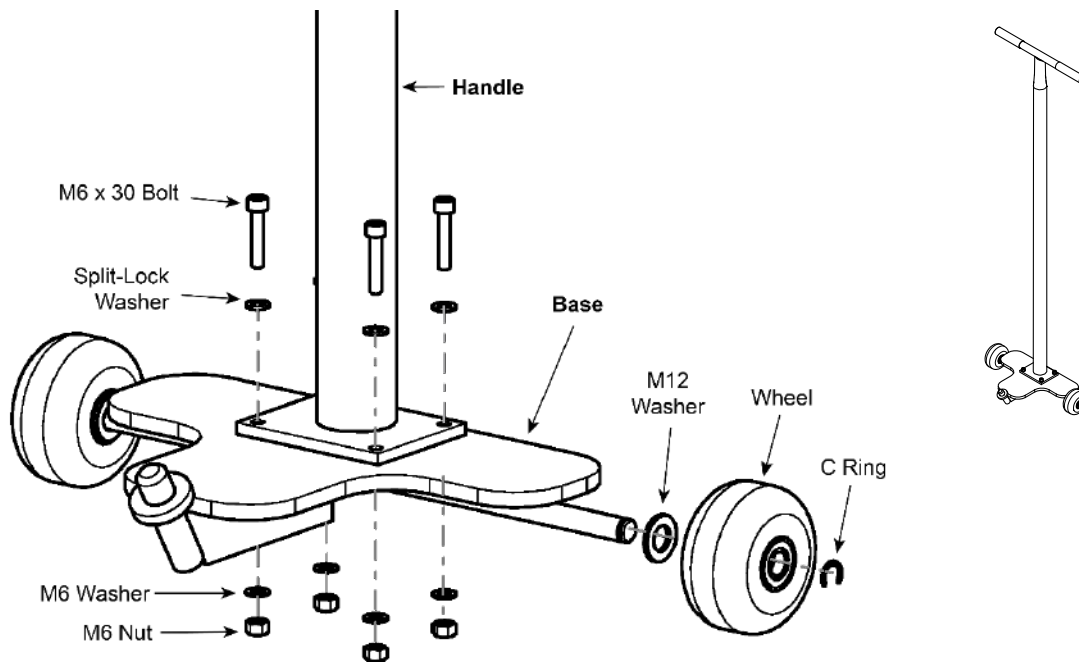

Raise the Platforms Off the Base (LR-60 only)

You need to raise the Platforms off the Base to access two of the three Anchor Bolt holes (see [Anchor the Bases](#) for Anchor Bolt locations).

Be sure to leave the Lift engaged on a Safety Lock when you raise it.

⚠ WARNING BendPak strongly recommends using **at least two people** to lift the Platforms off their Bases: one person to hold down the Base and one person to operate the Forklift or Shop Crane to raise the Platforms. **Use care when raising the Platforms off the Base.**

To lift the Platforms off the Base:

1. Use a Forklift or Shop Crane to raise the Platforms off the Base.
Make sure to hold down the Base while you raise the Platform.



Tip

Once the Platform and Base are separated by more than half an inch (~13 mm), you can put industrial slings (straps) around a Platform to continue raising the Platforms off the Base.

2. When the Platforms get above the top Safety Lock, lower it back down onto the top Safety Lock. Do **not** raise the Platforms a random distance; leave it on the top Safety Lock.

⚠ WARNING Do not continue with the installation without first confirming that the Lift is securely engaged on a Safety Lock.

About Embedment

Anchor Bolts (also called Wedge Anchors) get their holding strength from how far down into the Hole the Anchor Bolt is installed (called embedment) and how forcefully the Expansion Sleeve presses into the Concrete (based on how much torque is applied).

To get *enough* embedment, you have to understand *Effective* Embedment, which means the location in the Hole where the Expansion Sleeve presses into the Concrete. This is where the Anchor Bolts create holding strength; the further down into the Hole, the greater the holding strength.

(The technical definition of Effective Embedment is the distance from the surface of the base material to the deepest point at which the load is transferred to the base material; the “base material” in our case being the Concrete into which the Anchor Bolts are being installed.)

Some people confuse Effective Embedment with Nominal Embedment, which is how far down into the Hole the bottom of the Anchor Bolt is.

As shown below, the two are not the same. Nominal Embedment is **not** where the load is transferred to the base material, *Effective Embedment* is.

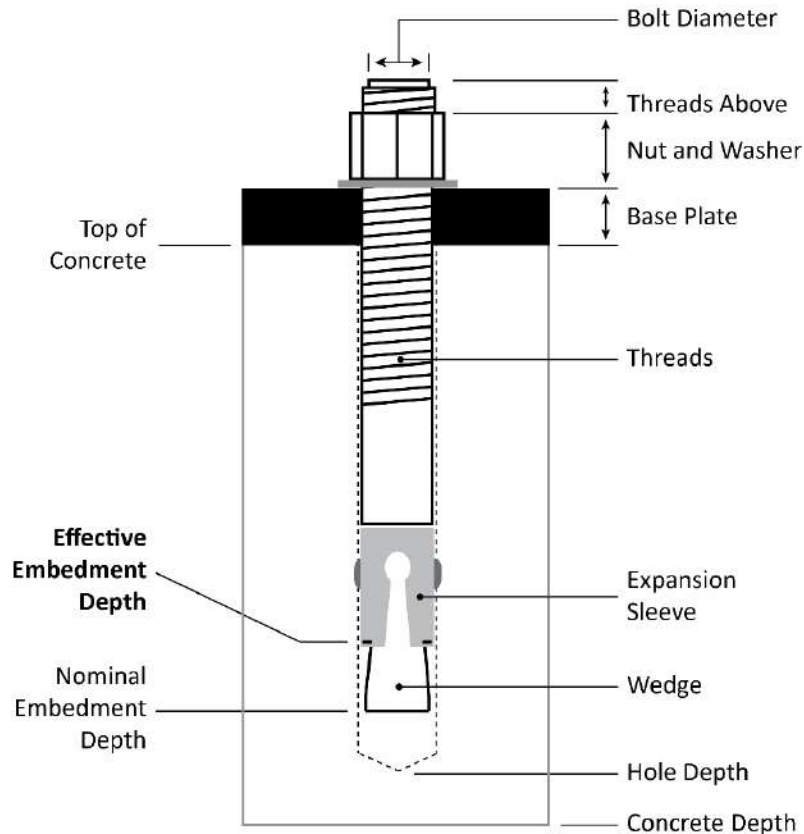

Not necessarily to scale.

The Anchor Bolts shipped with your product may have letters stamped into their tops, indicating their length.

For example:

- 4.75 in / 120 mm Anchor Bolts are stamped with a **G**.
- 6.3 in / 160 mm Anchor Bolts are stamped with a **J**.

Anchor the Bases (LR-60 only)

The Lift has three holes in the Base for anchoring it. Anchoring provides stability for the Lift.

Give a lot of thought to where you want the LR-60 **before** anchoring it: **once the Lift is anchored, it is extremely difficult to move.**

Concrete specifications are:

- **Depth:** 4.25 in (108 mm) thick
- **PSI:** 3,000 PSI, minimum
- **Cured:** 28 days, minimum

Anchor Bolt specifications are:

- **Length:** 4.75 inches
- **Diameter:** $\frac{3}{4}$ inch
- **Effective embedment:** 2.75 inches, minimum
- **Anchor torque:** 85 – 95 pound feet (do not torque less than 80 or more than 105)

Anchor Bolt holes must be at least 6 in / 152 mm away from expansion seams or cracked Concrete.

⚠ WARNING **Only use the factory-supplied parts that came with your Lift.** If you use parts from a different source, you void your warranty and compromise the safety of everyone who installs or uses the Lift.

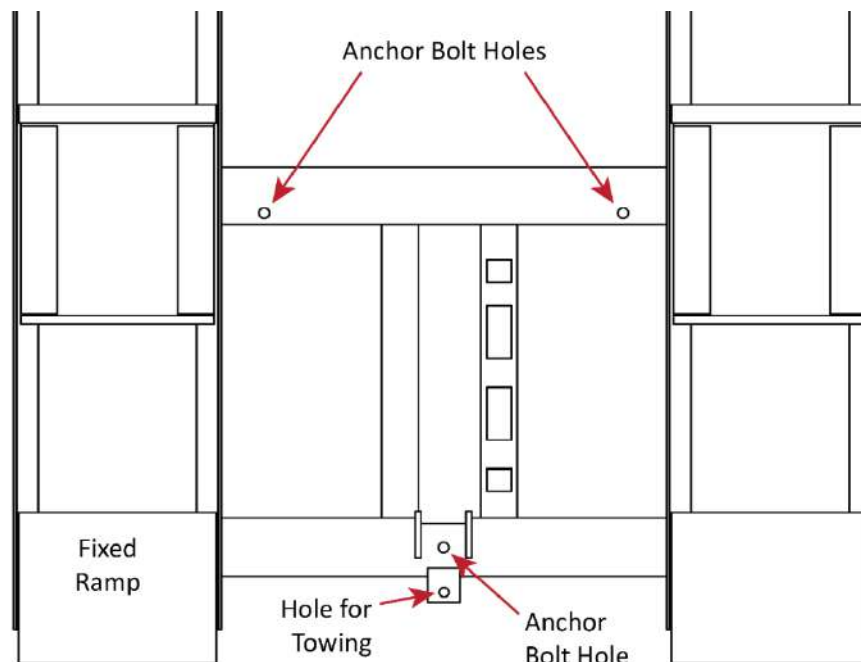

To anchor the Lift:

1. Make sure you are wearing OSHA-approved (publication 3151) Personal Protective Equipment: leather gloves, steel-toed work boots, back belts, hearing protection, and ANSI-approved eye protection (safety glasses, face shield, or goggles).
2. Make sure the Lift is in the desired location.
3. If it is not already, raise the Lift as high as it will go, then engage it on the top Safety Lock. Refer to **Raising a Vehicle** for lifting instructions.
4. Using the holes in the Bases as guides, drill each hole **4 in / 101 mm deep**.

Note: If you prefer, you can mark the Anchor Bolt hole locations, move the unit out of the way, drill the holes, and then move the unit back into position.

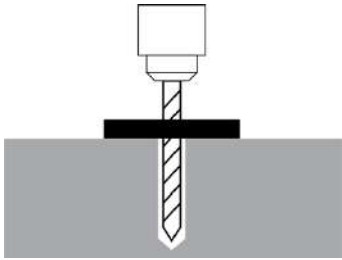

When drilling, go in straight; do not let the drill wobble.
Use a carbide bit (conforming to ANSI B212.15).

The diameter of the drill bit **must** be the same as the diameter of the Anchor Bolt. So if you are using a 3/4 inch diameter Anchor Bolt, for example, use a 3/4 inch diameter drill bit.

5. Use a wire brush and a vacuum to **thoroughly** clean each hole.

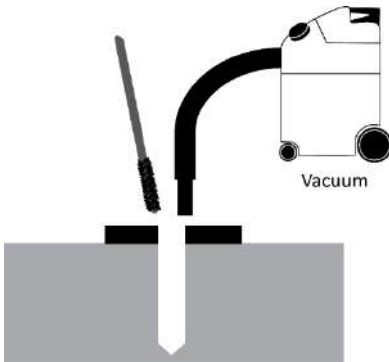

You can also use a hand pump or compressed air. Make sure to thoroughly clean the holes.

Do **not** ream the hole. Do **not** make the hole any wider than the drill bit made it.

6. Make sure the Washer and Nut are in place and flush with the top of the Bolt, then insert the Anchor Bolt into the hole.
7. Hammer or mallet the Anchor Bolt the rest of the way down into the hole.
Stop hammering when the Washer is snug against the Base.

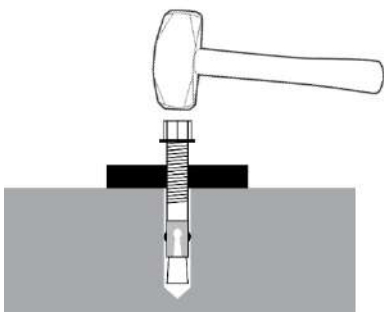

Use a hammer or mallet to get the Expansion Sleeve through the Base and down into the hole.

Even using a hammer or mallet, the Anchor Bolt should only go into the hole part of the way; this is normal. If the Anchor Bolt goes all the way in with little or no resistance, the hole is too wide.

Once past the hole in the Base, the Anchor Bolt eventually stops going down into the hole as the Expansion Sleeve contacts the sides of the hole; this is normal.

8. Torque each Nut **clockwise** to the recommended installation torque, 85 – 95 pound feet (do not torque less than 80 or more than 105), using a Torque Wrench.

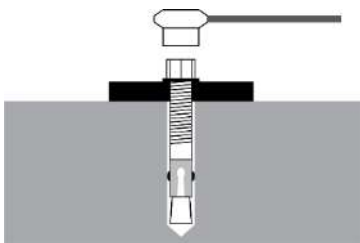

Wrenching the Nut forces the wedge up, pushing out the Expansion Sleeve and pressing it tightly against the Concrete.

Important: Do **not** use an impact wrench to torque the Anchor Bolts.

Anchor the Power Unit Stand (LR-60 only)

The LR-60 comes with a Power Unit Stand to hold the supplied Power Unit; it can be on either side of the Lift. The Power Unit Stand **must** be anchored.

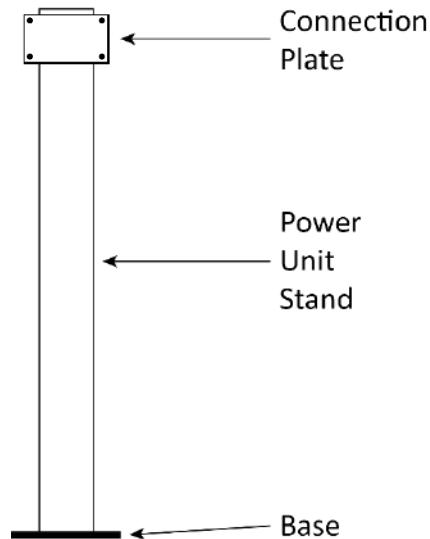

Not necessarily to scale. Not all components shown.

To anchor the Power Unit Stand:

1. Select an appropriate site for the Power Unit Stand.
2. Find the Power Unit Stand and two Anchor Bolts ($\frac{3}{4}$ " wide, 4 $\frac{3}{4}$ " deep, same size as the Anchor Bolts holding down the Lift).
3. Follow the anchoring instructions from the previous procedure to anchor the Power Unit Stand.
See [Anchor the Bases](#) for more information.
4. Once the Power Unit Stand is anchored, attach the Power Unit to it using the supplied M8 x 20 Bolts, M10 Washers, and M8 Nuts.

⚠ CAUTION The Power Unit is heavy and awkward; we recommend having at least two people work together to attach the Power Unit to the Power Unit Stand.

5. Use an appropriate tool to securely tighten the connections.

Install the Wheels (LR-60P only)

The **LR-60P** comes with two Wheel Assemblies; they come assembled, but they must be installed on top of the Wheel Brackets, which are located next to the Hinged Ramps.

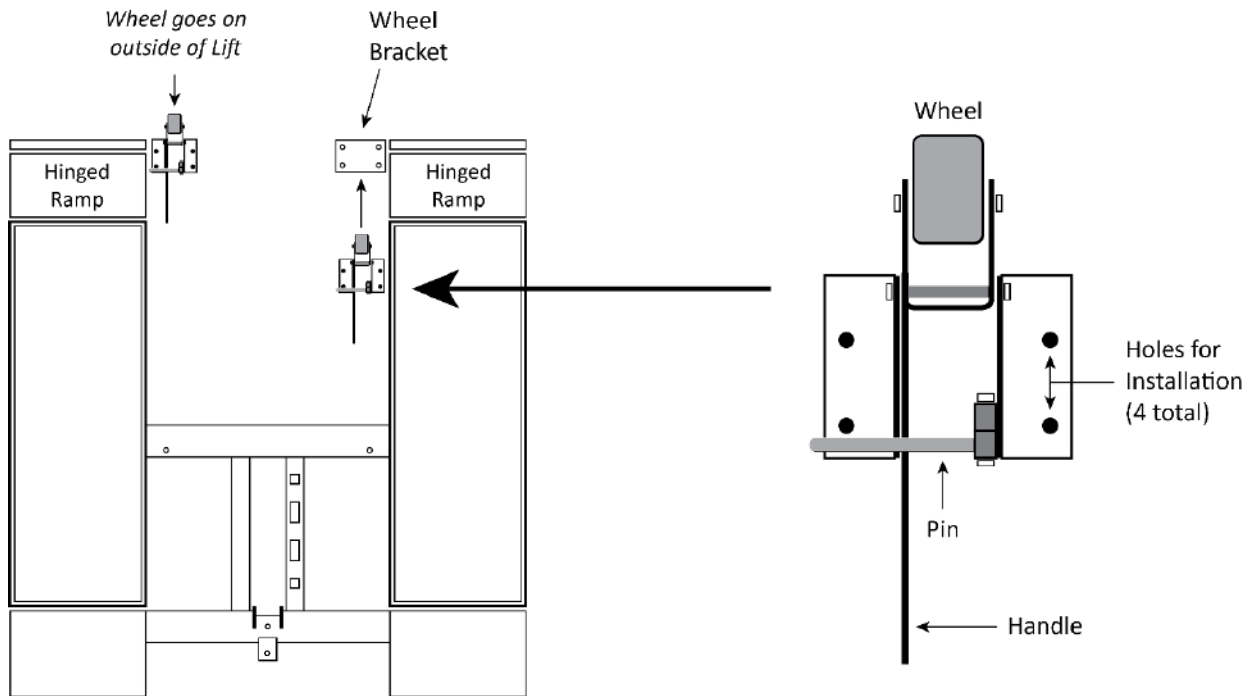

Not necessarily to scale. Not all components shown.

To install the two LR-60P Wheels:

1. Locate the two Wheel Assemblies and the eight Bolts/Split Washers/Nuts.
2. Use a lifting device (such as a jack) to **raise** the Hinged Ramp end of the Lift up off the ground approximately 6 in / 152 mm **and hold it up**.
3. Put one of the Bolts into place through a Hole in the Wheel Bracket **from underneath**.
4. Put a Wheel Assembly into place on top of the Wheel Bracket, then put a Split Washer and Nut onto the Bolt Threads.

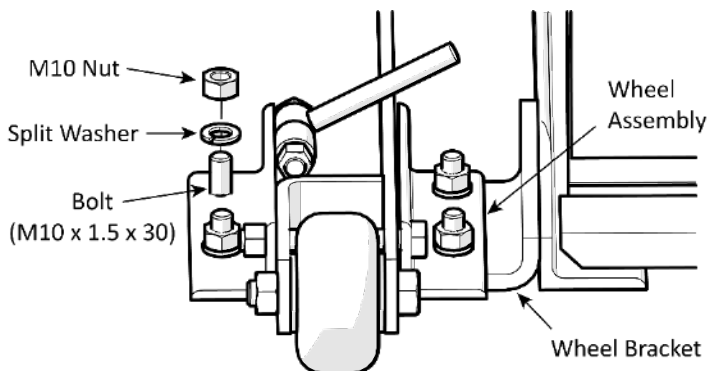

5. Put the other three Bolts/Split Washers/Nuts into place and finger tighten the Nuts.
6. Repeat Steps 3 through 5 for the other Wheel Assembly.
7. Use an appropriate tool to **securely tighten** all of the Nuts and then lower the Hinged Ramp end of the Lift back down to the ground.

Hydraulic Fluid Contamination

Hydraulic Fluid contamination poses a **serious** issue for your Lift; contaminants such as water, dirt, or other debris can get into the Hydraulic Hoses and Fittings of your Lift, eventually getting into the Hydraulic Fluid. Once debris is in the system, you could experience issues such as one Platform lowering faster than the other, internal and external Hydraulic Fluid leaks, slow operation, and so on.

Your Lift is shipped from the factory with clean components; however, BendPak **strongly** recommends that you give the hydraulic components an extra cleaning. Even a small grain of debris introduced into the Hydraulic System is enough to make the Lift unusable. It is better (and less costly) to take these extra steps now, so that you do not need to take your Lift out of service later to fix issues that could have been prevented.

What you need to do

When you get to the procedure describing how to connect the Hydraulic Hose, make sure to take a survey of the Hydraulic components that come with your Lift **prior** to making connections. There are several ways to clean the Hydraulic Hoses and Fittings:

- Use an air compressor to blow out contaminants. Clean, dry air is preferred. Keep in mind that the contaminants are going to be coming out the other end, so be prepared for that.
- For Hoses with ends not secured with Fittings, use a projectile cleaning system that shoots expandable cleaning “pellets” through the Hydraulic Hoses to clean them all the way through. HydraCheck, Eaton, and Ultra Clean make these types of systems.
- For Hydraulic Hose ends and Fittings that are not too long, soak part of a rag in the same Hydraulic Fluid you will be putting in the reservoir, then use the rag to clean out the Fittings and the ends of the Hydraulic Hoses. Do **not** use water or other cleaning fluids, as they should never be mixed with Hydraulic Fluid.

Some additional steps that will help keep your Hydraulic System clean:

- **Always use clean equipment.** If you use a dirty bucket or funnel to transfer the Hydraulic Fluid into the Hydraulic Fluid Reservoir, the contaminants will likely be introduced into the Fluid. When using cleaning rags, use a lint-free rag.
- **Proper Storage.** Keep the Hydraulic Fluid sealed in its container until ready for use; store the fluid in a clean, dry, and cool area.
- **Cover the Hoses and Fittings.** Before installation, do not leave the ends of the Fittings exposed; the same applies for Hydraulic Hoses. As a general rule, keep the Hydraulic Hoses and Fittings capped and kept in a clean area until ready for use.
- **Filter the new Hydraulic Fluid.** Just because it is new does not necessarily mean it is *clean*. Use an offline filtration cart or kidney loop system to make sure the Hydraulic Fluid is clean **before** being transferred into the Hydraulic Fluid Reservoir.
- **Avoid mixing different types of Hydraulic Fluid.** If Hydraulic Fluid needs to be replaced, make sure to flush the Hydraulic System of the old Hydraulic Fluid before you add the replacement fluid; do *not* mix the two together.
- **Remove old thread seal tape.** Some fittings are shipped with temporary plugs secured with thread seal tape, so make sure to thoroughly remove the thread seal tape **before** attaching an NPT Fitting; this prevents pieces of the tape from being pushed into the Hydraulic System. If NPT Fittings on the Hydraulic Cylinders need to be removed or replaced, use a liquid thread sealant.
- **Flush out the Hydraulic System.** Drain the Hydraulic System of the current Hydraulic Fluid, then cycle the Lift a few times using low-viscosity flushing liquid to push out debris trapped in the system; make sure the flushing liquid is compatible with the working fluid.

About Thread Sealants

Your Lift comes with a bottle of Liquid Thread Sealant.

Thread Sealant lubricates and fills the gaps between the Fitting threads, and leaves no residue that could contaminate the Hydraulic Fluid. Other types of sealants can shred during installation or removal and eventually enter the Hydraulic System.

To apply Thread Sealant:

1. Make sure the Fittings and connectors you are going to use are clean and dry.
If you are adding Thread Sealant to a Fitting or connector that has already been used with a different sealant, use a wire brush to thoroughly remove the old sealant before adding more.
2. Apply a small amount of Thread Sealant to the first four threads of the Fitting.

 **WARNING** Make sure to wear the proper protective equipment when handling Thread Sealant.

You only need a small amount because the sealant spreads to the other threads as it is tightened into place.

If you put too much, the excess liquid will be pushed out when the Fitting is tightened; use a rag to wipe the excess.

3. Tighten the Fitting into the connector; do **not** over tighten the Fitting.
4. Allow the manufacturer-recommended curing time before pressurizing the system.

Connect the Hydraulic Hose

The Hydraulic Hose connects the Power Unit to the Hydraulic Cylinder on the Lift. Connecting the Hydraulic Hose is slightly different for each model, those procedures are described here.

For the **LR-60P only**, you usually only have to install the Male Quick-Connect Fittings (to the Power Unit) *once*. To move your LR-60P later, just disconnect the Power Unit from the Hydraulic Hose using the Quick-Connect Fittings.

The following drawing shows the Hydraulic connections for the LR-60.

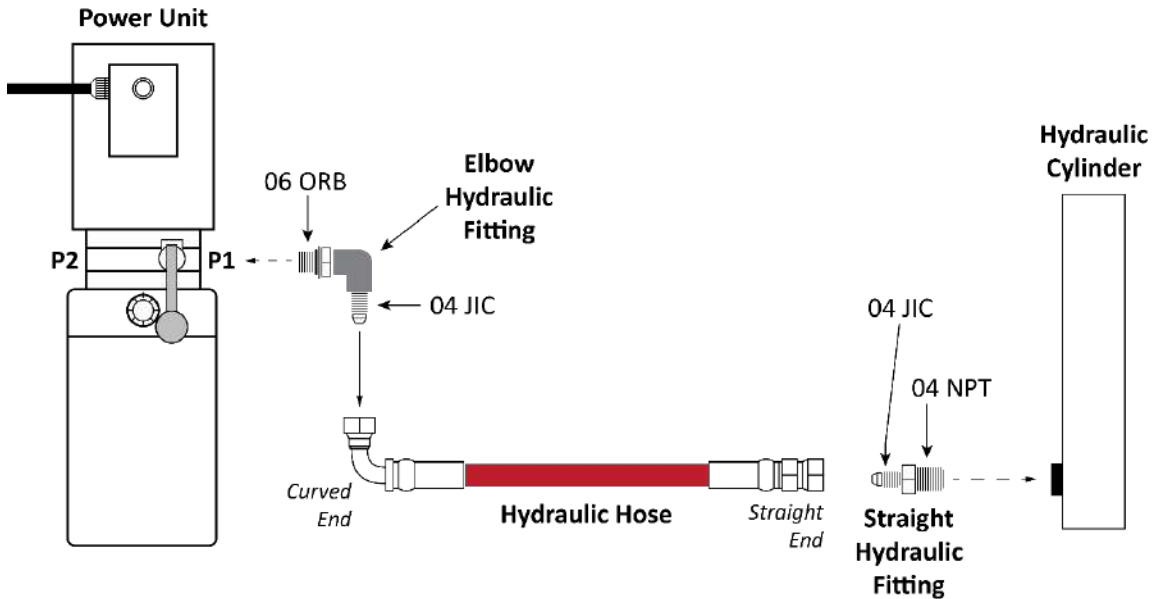

Drawing not to scale. Some components not shown.

The following drawing shows the Hydraulic connections for the LR-60**P**.

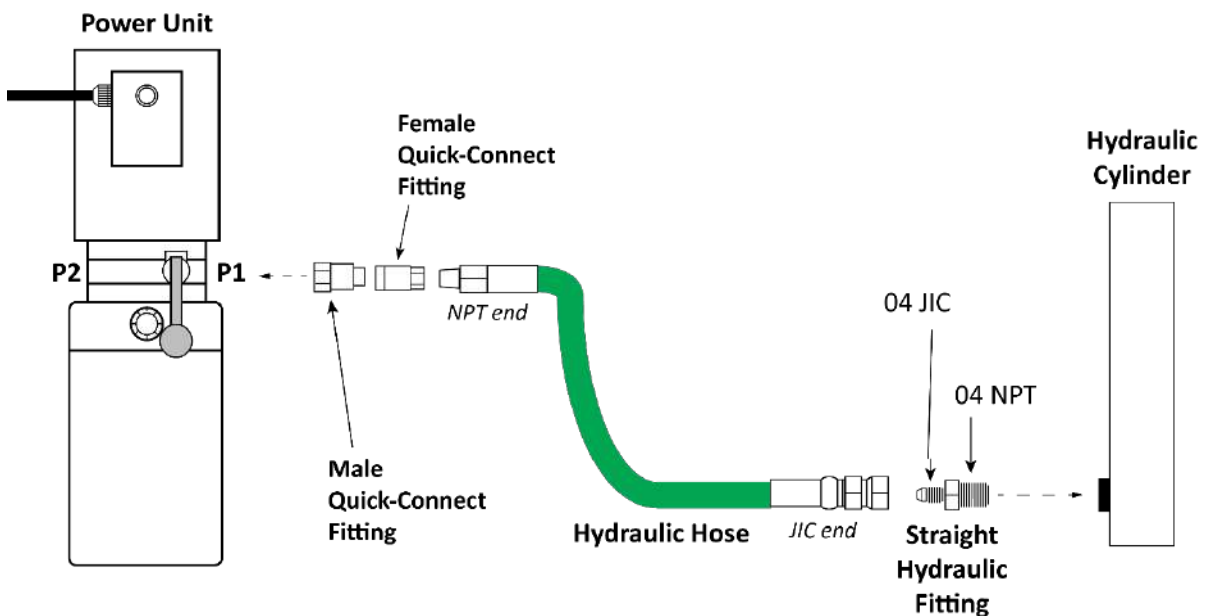

Drawing not to scale. Some components not shown.

 **CAUTION** Do not let contaminants get into the Lift's Hydraulic System. Only use Liquid Thread Sealant where the instructions say it can be used. Do **not** use Thread Seal Tape.

To connect the Hydraulic Hose:

1. Prepare the Hydraulic components using the information in **Hydraulic Fluid Contamination**.
2. Remove the Shipping Plug from one of the two Hydraulic Power Out ports on the Power Unit.
The Hydraulic Power Out Ports are commonly labeled P1/P2 on the Power Unit.
3. For the LR-60, attach the 06 ORB connector of the Elbow Hydraulic Fitting (06 ORB – 04 JIC) to the Hydraulic Power Out Port.
For the LR-60**P**, attach the Male Quick-Connect Fitting to the Hydraulic Power Out Port.
4. For the LR-60, attach one end of the Hydraulic Hose to the 04 JIC end of the Elbow Hydraulic Fitting you just attached to the Power Unit.
For the LR-60**P**, attach the Female Quick-Connect Fitting to the NPT end of the Hydraulic Hose, then attach it to the Male Quick-Connect Fitting you just attached to the Power Unit.
5. Remove the Shipping Plug from the port at the bottom of the Hydraulic Cylinder.
6. Route the other end of the Hydraulic Hose from the Power Unit, under the Fixed Ramp, and to the Hydraulic Cylinder.
7. Attach the 04 NPT end of the Straight Hydraulic Fitting (04 JIC – 04 NPT) to the port on the Hydraulic Cylinder, then connect the Hydraulic Hose to the Straight Fitting.
If you like, you can use liquid thread sealant on the NPT connector to help prevent leaks. Do not use thread seal tape.
8. Use appropriate tools to **securely** tighten all of the connections.

Add Hydraulic Fluid

The Hydraulic Fluid Reservoir on the Power Unit must be filled with Hydraulic Fluid or automatic transmission fluid **before** you begin normal operation of the Lift.

The Hydraulic Fluid Reservoir holds approximately **1.5 gallons / 5.5 liters**.

Approved fluids are any general purpose ISO-32, ISO-46, or ISO-68 Hydraulic Fluid, approved automatic transmission fluids such as Dexron III, Dexron VI, Mercon V, Mercon LV, or any synthetic multi-Vehicle automatic transmission fluid.

Take care to **keep contaminants out** of the Hydraulic Fluid Reservoir.

 **WARNING** Do not run your Power Unit without Hydraulic Fluid; you will damage it.

Reconfigure the Power Unit to 230 VAC (optional)

The Power Unit comes fully assembled from the factory, configured for 115 VAC operation. To use the Power Unit with 230 VAC power, you need to reconfigure it.

⚠ DANGER Reconfiguring the Power Unit to use 230 VAC power **requires** a licensed, certified Electrician. Attempting to reconfigure your Power Unit without using an Electrician voids your warranty and puts everyone who uses the Lift in danger.

The Power Unit for the Lift is 115 VAC or 230 VAC, 50/60 Hz, 1 phase.

Additional important electrical information:

- Improper electrical installation can damage the Power Unit motor; this damage is **not** covered by the warranty.
- If you have multiple Power Units, use a separate circuit breaker for each Power Unit.
- Protect each circuit with a time-delay fuse or circuit breaker. For a 230 VAC, 1 phase circuit, use a 25 amp or greater fuse.
- The Lift uses electrical energy; if your organization has Lockout/Tagout policies, make sure to implement them once the unit is connected to a power source.
- The Power Unit's motor is **not** thermally protected.

⚠ DANGER Do not begin to reconfigure the Power Unit to use 230 VAC power without first making sure electrical power is disconnected from the Lift and **cannot** be re-energized until the procedure is complete.

To reconfigure the Power Unit to use 230 VAC power:

1. Find the Power Cord; cut off the 115 VAC plug that comes with the unit.
2. Wire a 230 VAC plug to the end of the Power Cord.

Refer to **Wiring Diagrams** for wiring information.

You can also take off the Electrical Panel Cover (around the Raise button); wiring information is on the inside of the Cover.

3. Plug the Power Cord in to a *grounded* 230 VAC outlet.

Connect to Power

The Power Unit comes fully assembled from the factory, configured for 115 VAC operation. An Electrician is **not** required to connect to a 115 VAC power source.

The Power Unit can also be reconfigured for 230 VAC. An Electrician is **required** to reconfigure the Power Unit to use 230 VAC power. Refer to **Reconfigure the Power Unit to 230 VAC (optional)** for details.

⚠ DANGER Reconfiguring the Power Unit to use 230 VAC power **requires** a licensed, certified Electrician. Attempting to reconfigure your Power Unit without using an Electrician voids your warranty and puts everyone who uses the Lift in danger.

The Power Unit for the Lift is 115 VAC **or** 230 VAC, 50/60 Hz, 1 phase. The circuit must be grounded and protected with a time-delay fuse or circuit breaker. For a 115 VAC, 1 phase circuit, use a 20 amp or greater breaker. For a 230 VAC, 1 phase circuit, use a 25 amp or greater breaker.

Important: The Lift uses electrical energy; if your organization has Lockout/Tagout policies, make sure to implement them once the unit is connected to a power source.

⚠ CAUTION The Power Unit's motor is **not** thermally protected.

To connect to 115 VAC power:

1. Find the Power Cord on the Power Unit.
2. Verify that the Power Cord has a 115 VAC plug on the end and that it has **not** been reconfigured to operate at 230 VAC.
3. Plug the 115 VAC plug into a *grounded* 115 VAC outlet.
4. Begin using the Lift.

To connect to 230 VAC power:

1. Verify that the supplied Power Unit has been reconfigured for 230 VAC operation; the Power Unit comes from the factory configured for 115 VAC.

The process for reconfiguring the Power Unit to 230 VAC operation is described in **Reconfigure the Power Unit to 230 VAC (optional)**.

2. When you have confirmed that the Power Unit has been reconfigured to 230 VAC operation, find the 230 VAC plug on the end of the Power Cord.

If the Power Cord still has a 115 VAC plug, then the supplied Power Unit was **not** successfully converted to 230 VAC operation. Contact the Electrician or your Supervisor **before** proceeding.

3. Plug the 230 VAC plug into a *grounded* 230 VAC outlet.
4. Begin using the Lift.

Test the Lift

Before putting your Lift into normal operation, we recommend raising and lowering it a few times with a typical Vehicle on it.



Tip

Residual air in the Hydraulic System can cause the Lift to shake, move erratically, or squeak; this is normal when you first start using the Lift. It will soon stop doing this, as the Hydraulic System is self-bleeding.

To test your Lift:

1. Check the items listed in **Lift Operation Safety**.

If you find any issues, resolve them before raising the Vehicle.

2. Make sure both Platforms are fully lowered.
3. Drive the Vehicle over the Platforms and situate it correctly.

CAUTION

Make sure to situate the Vehicle so that neither the front nor the rear wheels are over the Platforms. If you raise the Platforms with the wheels over the Platforms, you could damage the wheels.

4. Put the Vehicle in park, put on the parking brake, and turn off the Vehicle.
If the Vehicle is a manual transmission, put it into first gear before turning it off.
5. Walk around the Vehicle and make sure there are no obstructions or any other issues that will interfere with the raising of the Platforms.
6. Locate the manufacturer's recommended Lifting Points for the Vehicle you are raising.

If you are unsure where the Lifting Points are, consult *Vehicle Lifting Points for Frame Engaging Lifts*, available on the ALI store (autolift.org/ali-store/) or the manufacturer of the Vehicle.

WARNING

Do not 'eyeball' the best location for the Lift Pads. **The Lift Pads must hit the manufacturer's recommended Lifting Points.** If you do not, the Vehicle could become unstable and fall, which could damage the Vehicle, damage the Lift, or injure or even kill anyone under the Vehicle.

7. Put the Lift Pads under the Vehicle so that they are **directly under** the Lifting Points.
8. On the Power Unit, press and hold the **Raise** button to raise the Lift until **just before** the Lift Pads make contact with the Lifting Points on the underside of the Vehicle.
9. Make sure the Lift Pads will make solid contact with the Lifting Points when raised further; adjust them if necessary.
10. Raise the Lift until the Lift Pads contact the underside of the Vehicle and raise the tires of the Vehicle a few inches off the ground.
11. Visually check to make sure the Lift Pads are making solid contact with the Lifting Points.

If any of the Lift Pads are **not** making solid contact with the Lifting Points, lower the Lift and adjust the Lift Pads so that they make better contact.

DANGER

Do not raise the Lift further until you are certain the Vehicle on the Lift is both stable and balanced. If the Vehicle is **not** stable and balanced, it could fall, which could damage the Vehicle, damage the Lift, or injure or kill anyone under the Vehicle.

12. On the Power Unit, press and hold the **Raise** button.

Watch the Vehicle and the Platforms as they rise.

13. When the Platforms are *just past* the desired Safety Lock, release the **Raise** button.

14. Press the Lowering Handle on the Power Unit to move the Platforms back down a little, which engages them on the most recently passed Safety Lock.

If you miss the Safety Lock (the Lift continues moving down), press and hold **Raise** again and go somewhat further past the desired Safety Lock, then hold the Lowering Handle again to lower the Lift and engage it on the Safety Lock.

15. To lower the Lift back down to the ground, *press and hold* **Raise** to move the Lift up until the Safety Lock is in an unlocked position, then press and hold the Lowering Handle until the Lift is fully lowered.

If the Lift was shaking, moving erratically, or squeaking, raise and lower the Lift again to help bleed the Hydraulic System.

If you continue to have issues, refer to **Troubleshooting** for assistance.

Final Checklist Before Operation

Make sure the following items have been done before using your Lift:

- Review the **Installation Checklist** to make sure all steps have been performed.
- Make sure the Power Unit is getting power from the power source.
- Check the Hydraulic Fluid reservoir; it must be full of approved Hydraulic Fluid or automatic transmission fluid. ***You can harm the motor by running it without enough fluid.***
- Check the Hydraulic System for leaks.
- Check to see that all Anchor Bolts are in place and correctly torqued.
- Make sure that the Safety Locks are cleared and free.
- Leave the Manual with the Owner/Operator so that it is available for anyone who needs to read it.

Operation

This section describes how to operate your Lift.

⚠ DANGER Using an Automotive Lift is a serious endeavor with potentially life-threatening risks. Only trained, authorized, supervised personnel may be within 30 feet of the Lift while it is in use. **Do not assume you are going to be safe using the Lift this time just because nothing happened last time.**

Lift Operation Safety

BendPak recommends referring to the ANSI/ALI ALIS Standard (R2015) *Safety Requirements for Installation and Service*, available from the Automotive Lift Institute store (autolift.org/ali-store), for more information about safely installing, using, and servicing your Lift.

Before you raise or lower a Vehicle using your Lift, do the following each time:

- **Check the Lift.** Check the Lift for any missing, heavily worn, or damaged parts. Do not operate the Lift if you find any issues; instead, take it out of service, then contact your dealer, email support@bendpak.com, visit bendpak.com/support, or call **(800) 253-2363**, x196.
- **Check the area.** Check the area around the Lift for obstructions; anything that might block the Lift. Do not forget to check **above** the Lift. If you find an obstruction, move it out of the way.
- **Check the operators.** Make sure everyone who is going to operate the Lift has been trained in its use, has read the labels on the unit, and has read the manual. Only the operator at the Console should be within 30 feet of the Lift when it is in motion.
- **Check for safety.** Make sure everyone who is going to be walking near the Lift is aware of its presence and takes appropriate safety measures. Only put Vehicles on the Lift. **When raising the Lift, do not leave it until it is engaged on a Safety Lock.** When lowering the Lift, do not leave it until it is fully lowered. Do not allow children or untrained personnel to operate the Lift. Do not allow anyone under the influence of drugs or alcohol to operate the Lift.
- **Check the Vehicle.** Never exceed the Lift's weight rating. Do not allow people inside a Vehicle you are going to raise. Before raising it, make sure the Vehicle is not overbalanced on either end. Make sure you know and use the manufacturer's recommended Lifting Points for the Vehicle. Never raise just one side, one corner, or one end of a Vehicle.

Lift Controls

The controls on the Lift are:

- **Raise Button.** Moves the Platforms up. Located near the top of the Power Unit.
- **Lowering Handle.** Moves the Platforms down. Handle with round ball at end, located near the middle of the Power Unit.

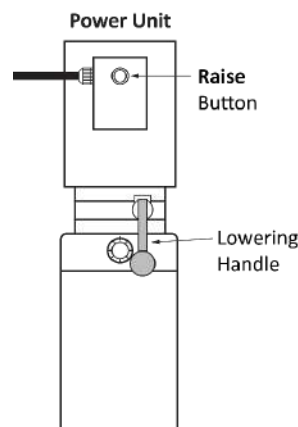

Raising a Vehicle

This section describes how to position a Vehicle on the Lift and raise it.

To raise a Vehicle:

1. Check the items listed in **Lift Operation Safety**.

If you find any issues, resolve them **before** raising the Vehicle.

Only use the Lift if it can be used safely.

2. Make sure both Platforms are fully lowered.
3. Drive the Vehicle over the Platforms and situate it correctly.

⚠ CAUTION Make sure to situate the Vehicle so that neither the front nor the rear wheels are over the Platforms. If you raise the Platforms with the wheels over the Platforms, you could damage the wheels.

4. Put the Vehicle in park, put on the parking brake, and turn off the Vehicle.

If the Vehicle is a manual transmission, put it into first gear before turning it off.

You do not want the Vehicle moving while it is raised.

5. Walk around the Vehicle and make sure there are no obstructions or any other issues that will interfere with the raising of the Platforms.

6. Locate the manufacturer's recommended Lifting Points for the Vehicle you are raising.

If you are unsure where the Lifting Points are, consult *Vehicle Lifting Points for Frame Engaging Lifts*, which was provided with the Lift, or the manufacturer of the Vehicle. If you no longer have *Vehicle Lifting Points for Frame Engaging Lifts*, you can get a replacement on the ALI website.

⚠ WARNING: Do not 'eyeball' the best location for the Lift Pads. **The Lift Pads must hit the manufacturer's recommended Lifting Points**, if they do not, the Vehicle could become unstable and fall, which could damage the Vehicle, damage the Lift, or injure or even kill anyone under or near the Vehicle.

7. Put the Lift Pads under the Vehicle so that they are **directly under** the Lifting Points for the Vehicle you are raising.

If necessary, use the included Lift Pad Extensions for extra height.

8. On the Power Unit, press and hold the **Raise** button to raise the Lift until **just before** the Lift Pads make contact with the Lifting Points.

9. Make sure the Lift Pads will make solid contact with the Lifting Points when raised further.

Adjust them if necessary.

10. Raise the Lift until the tires of the Vehicle are a few inches off the ground.

11. Visually check to make sure the Lift Pads are making solid contact with the Lifting Points.

If any of the Lift Pads are **not** making solid contact with the Lifting Points, lower the Lift and adjust the Lift Pads so that they make better contact.

⚠ DANGER Do not raise the Lift further until you are certain the Vehicle on the Lift is both stable and balanced. If the Vehicle is **not** stable and balanced, it could fall, which could damage the Vehicle, damage the Lift, or injure or kill anyone under the Vehicle.

-
12. On the Power Unit, press and hold the **Raise** button.
 13. Watch the Vehicle and the Platforms as they rise.
If the Lift becomes unstable or the Vehicle starts moving, release the **Raise** button immediately.
 14. When the Platforms are just past the desired height, release the **Raise** button.
The Lift stops rising.
 15. Press the Lowering Handle to move the Platforms back down, which engages them on the most recently passed Safety Lock.
If you miss the Safety Lock, press and hold **Raise** again and go somewhat further past the Safety Lock, then hold the Lowering Handle again to engage the Lift on the Safety Lock.
 16. Rock the Vehicle to make sure the Vehicle is stable and balanced.
If the Vehicle is **not** stable and balanced, lower the Lift back to the ground and start over.
If the Vehicle **is** stable and balanced, it is safe to begin working on your Vehicle.

Lowering a Vehicle

This section describes how to lower a Vehicle from a raised position.

To lower a Vehicle:

1. Check the items listed in **Lift Operation Safety**.
If you find any issues, resolve them before lowering the Vehicle.
Only use the Lift if it can be used safely.
2. Press and hold the **Raise** button for a second or two to move the Platforms off the Safety Lock.
3. Move the Safety Lock Release Handle to the Raised position (which pushes the Safety Lock Bar up, allowing the Safety Locks to be passed by).
4. Press and hold the Lowering Handle.
5. Release the Lowering Handle when the Lift is fully lowered.
6. Move the Safety Lock Release Handle back to the Lowered position.
7. Carefully drive the Vehicle off.

Moving the LR-60P

The LR-60**P** is portable; you can move it between locations as needed. The LR-60 is **not** portable.

⚠ DANGER Do **not** move the Lift or perform any maintenance to the Lift without first confirming that electrical power has been disconnected and cannot be re-energized.

The following drawing show the components used to move the Lift.

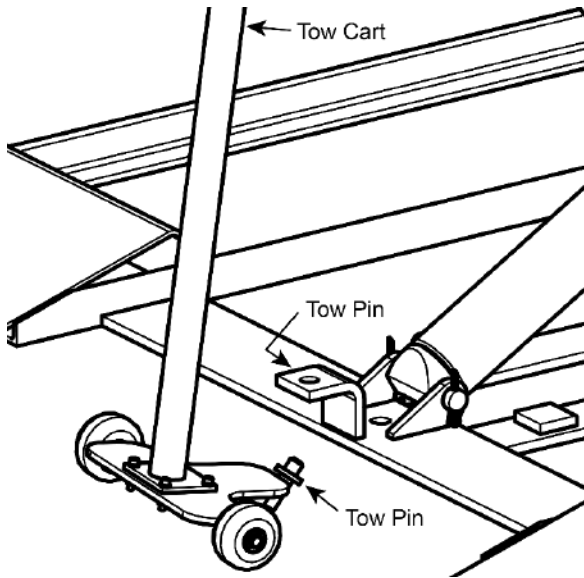

To move the Lift:

1. Make sure the Lift is fully lowered, then disconnect the Power Unit from the Hydraulic Hose using the Quick-Connect Fittings.

⚠ WARNING Do **not** attempt to connect or disconnect the Hydraulic Hoses while equipment is loaded or while the Hydraulic System is under pressure.

2. Pull up the Wheel Assembly Handle and flip down the Wheel Pin.

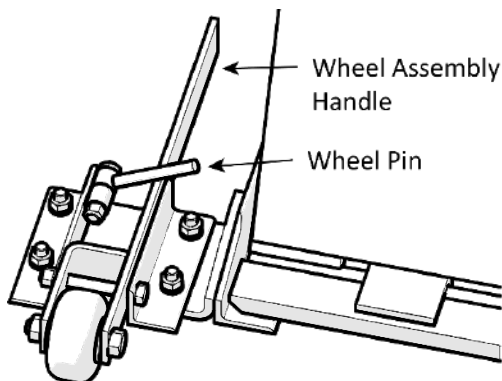

3. Using the Tow Cart, hook the Tow Pin into the Latch near the bottom of the Frame.
4. Using a downward force, push the Tow Cart to raise the Lift onto its rear wheels, and then carefully move the Lift to the desired location.
5. Remove the Tow Cart and lower the Wheel Assemblies.

Using the LR-4A Arm Kit

There is an Arm Kit optional accessory available for LR-60/60P, the LR-4A Arm Kit, which lets you hit the lifting points on wider Vehicles by allowing Lift Pads to extend past the sides of the Lift's Platforms.

The contents of the LR-4A Arm Kit include:

- **4 Lift Arms.** The Lift Arms slide over the sides of each Platform on the inside of the Lift, with the rest of the Lift Arm extending out over the outside edge of the Platform.
- **4 Tall Lift Blocks.** Each Tall Lift Block is 6 in / 152 mm high.
- **4 Medium Lift Blocks.** Each Medium Lift is 3 in / 76 mm high.

You can stack one Medium Lift Block on one Tall Lift Block, for a total of 9 inches of height, but not more than that.

⚠ WARNING *Never* stack more than one Medium Lift Block on one Tall Lift Block. If you do, the Vehicle will become unsteady, which could lead to it falling off the Lift, potentially causing injury to bystanders and damage to the Vehicle and the Lift.

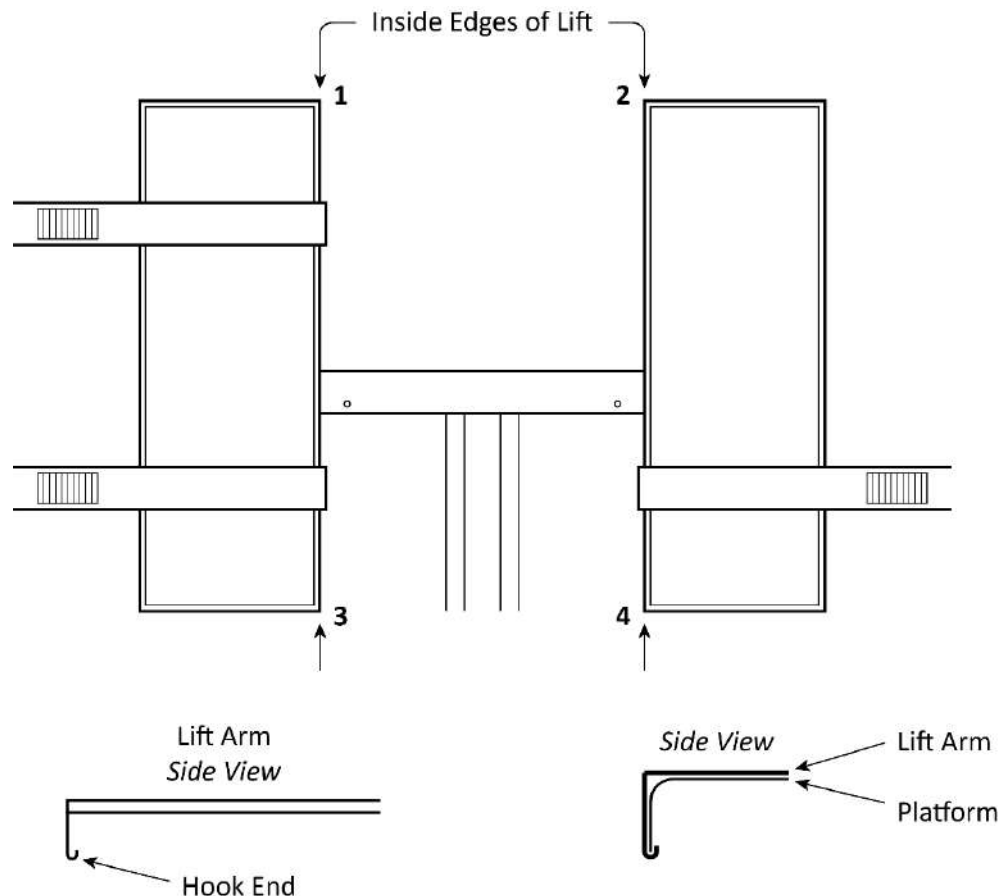

Top View, except where labeled Side View. Not necessarily to scale. Not all components shown.

To use the LR-4A Lift Arms:

1. Raise the Lift to the lowest Safety Lock and engage it there.
2. Take a Lift Arm, slide the hook end over the side of one of the Platforms (on the inside of the Lift, noted as **1**, **2**, **3**, and **4** in the drawing on the previous page, does not matter which one you do first), then move it in a little bit, towards the middle of the Platform.
3. Repeat Step 2 for the other three Lift Arms.
4. Put the Lift Blocks of the desired height in place in the Lift Arms.
5. Adjust the Lift Arms and the Lift Blocks so they will be under the Lifting Points on the underside of the Vehicle.
6. Lower the Vehicle down to the ground.
7. Drive the Vehicle over the Lift.
8. Raise the Lift until just **before** the Lift Blocks would make contact with the Vehicle's Lifting Points.
Check the locations where the Lift Blocks will hit the Lifting Points on the Vehicle. If necessary, adjust the Lift Blocks so that they are properly positioned (you may need to lower the Vehicle some to adjust the Lift Blocks).
9. After confirming the Lift Blocks are properly positioned, start raising the Lift.
The Lift Blocks hit the Vehicle's Lifting Points.
10. Make sure all Lift Blocks are in good contact with the Lifting Points.
If the Lift Blocks **are** in the right positions and making good contact, continue with the next step.
If the Lift Blocks are **not** in the right positions or not making good contact, **carefully** lower the Vehicle back down to the ground, then make the necessary adjustments.
11. If the Vehicle is stable, raise the Lift to the desired height, then engage the Lift on the closest Safety Lock.
12. Rock the Vehicle gently to test for stability.
If the Vehicle is **not** stable, **carefully** return the Vehicle to the ground, then make the necessary adjustments.
13. Once the Lift Blocks are in the right positions (under the Vehicle's Lifting Points) and making good contact, and the Vehicle is stable and engaged on Safety Locks, you can begin work.

Maintenance

⚠ DANGER Before performing any maintenance, make sure the Lift is completely disconnected from power and **cannot** be re-energized until all maintenance is complete. BendPak strongly recommends using your Power Disconnect Switch during maintenance. If your organization has Lockout/Tagout policies, make sure to implement them during all maintenance.

To maintain your Lift:

- **Daily:** Keep the Lift clean. Wipe up any oil spills, clean any dirt.
- **Daily:** Make a visual inspection of all moving parts and check for damage or excessive wear. If you find any damaged or worn parts, take the Lift out of service until they are replaced.
- **Daily:** Make sure the Safety Locks are in good operating condition. If you find that the Safety Locks are damaged or excessively worn, take the Lift out of service until they are replaced. **Do not use your Lift if the Safety Locks are damaged or excessively worn.**
- **Weekly:** Check all controls to make sure they are functioning normally.
- **Weekly:** Check all labels on the unit. Replace them if they are illegible or missing.
- **Monthly:** Lubricate the grease fittings. We recommend using white lithium grease or similar.
- **Monthly:** Check the Power Unit's Hydraulic Fluid levels. Refill if low.
- **Every two months:** Check all Anchor Bolts to make sure they are tight. If not, tighten them.

⚠ WARNING: Do not operate your Lift if you find issues; instead, take the Lift out of service, then contact your dealer, email support@bendpak.com, visit bendpak.com/support, or call **(800) 253-2363**, extension 196.

Lubrication

The following drawing shows the lubrication points for the Lift. Note that some lubrication points are under other parts of the Lift.

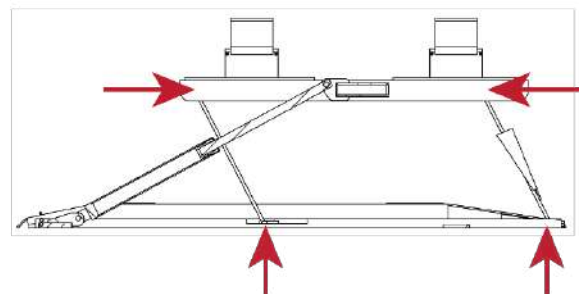
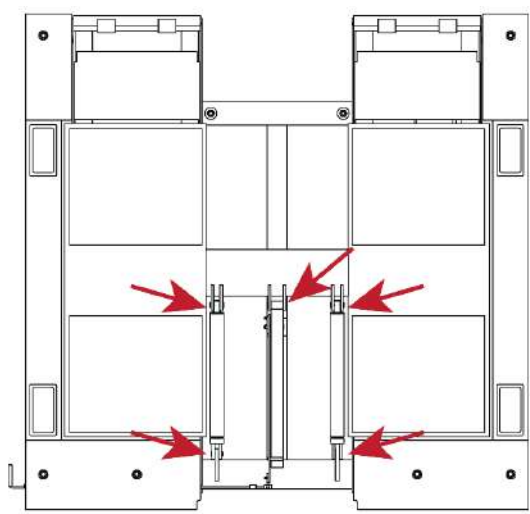

Troubleshooting

This section describes how to troubleshoot your Lift.

The Lift uses electrical and pneumatic energy; if your organization has Lockout/Tagout policies, implement them before performing any troubleshooting.

Note: If your Lift is not functioning correctly, you must take it out of service until it is fixed.

Important: All repair work *must* be done by qualified personnel.

| Issue | Action to Take |
|--|---|
| Platforms move erratically or squeak when in use. | Move the Platforms up and down a few times, with a break between each; there could be residual air in the Hydraulic System. |
| Platforms do not go up or down. | Make sure the Power Unit is connected to an appropriate power source. Make sure the Hydraulic Hose is not pinched or leaking. Make sure there is sufficient Hydraulic Fluid in the reservoir on the Power Unit. |
| Vehicle with no tires is fully lowered, Lift will not go up. | Too much weight on the Frames; no room to get upward motion started. Refer to Vehicle with No Tires Fully Lowered . |
| Hydraulic Fluid is old or dirty. | Replace the dirty fluid with clean, approved Hydraulic Fluids, such as Dexron III, Dexron VI, Mercon V, Mercon LV, Shell Tellus S4 / S3 / S2, or comparable. |
| Platforms make odd noises when in use. | Lubricate hinge points using white lithium grease. |
| Platforms are slowly lowering on their own. | Make sure both Platforms are engaged on Safety Locks (if not, Hydraulic Fluid could be leaking out, lowering the Platforms). Only leave the Lift either fully lowered or engaged on a Safety Lock. |

If you continue to have problems with your Lift, contact your dealer, visit bendpak.com/support, email support@bendpak.com, or call **(800) 253-2363**, extension 196.

Vehicle with No Tires Fully Lowered

The issue is that there is too much weight on the Lift with no room to get upward force started. You need to reduce the weight by at least half or raise the Vehicle off the Platforms some other way.

Methods that have fixed this issue include:

- Use a floor jack to raise the Vehicle from four to six inches, giving enough room to get upward force started.
- Use lifting equipment to raise the Vehicle off the Platforms.

If you are still unable to raise your Vehicle, contact BendPak Technical Support for assistance.

Wiring Diagrams

115 VAC

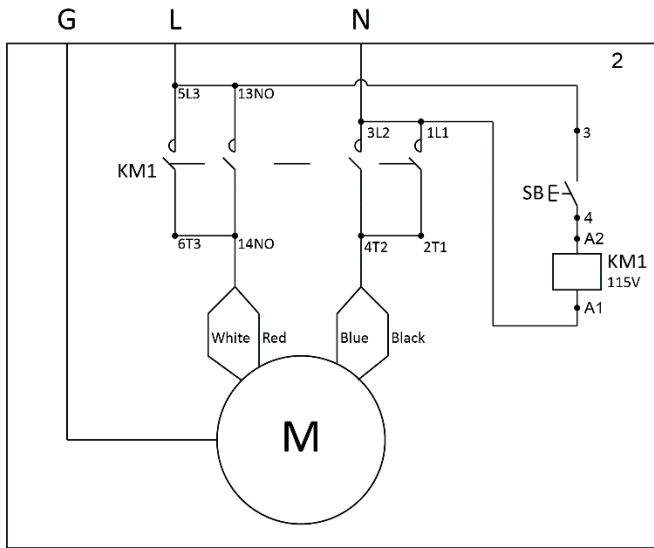

230 VAC

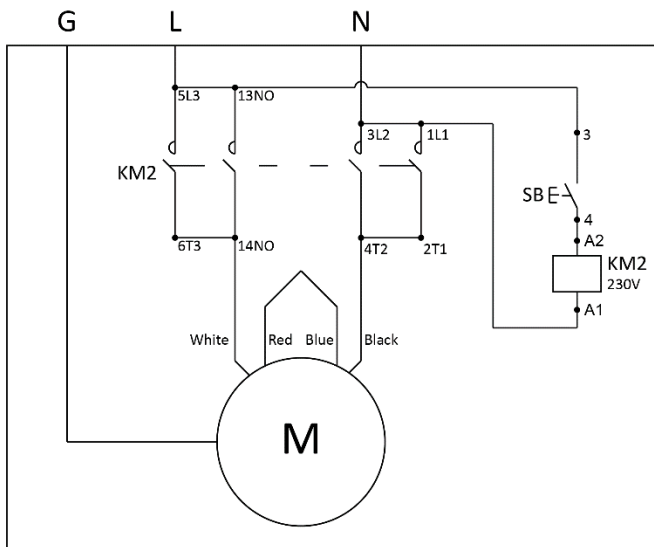

⚠ WARNING: All electrical work, such as reconfiguring the unit for 230 VAC operation, **must be done by a licensed, certified Electrician** in accordance with all applicable local electrical codes. Damage caused by improper electrical installation may void your warranty.

Labels

A



B



C

| | | | |
|--|---|--|---|
| <p>WARNING</p> <p>Read and understand all safety warning and operation procedures before using lift.</p> <p>Keep hands and feet clear from moving parts.</p> <p>OPERATION INSTRUCTIONS</p> <p>TO RAISE LIFT:</p> <ul style="list-style-type: none"> Clear area of personnel and make sure lift is in full lowered position. Drive vehicle over lift making sure center line of the vehicle is positioned properly over lift pads. Position lift pads underneath the vehicle making sure that they make secure contact with the factory recommended lifting points. Before raising, make sure the weight of the vehicle does not exceed rated capacity of lift. Push the RAISE button to commence lifting. Raise lift until the vehicle tires clear the floor. Stop then check if vehicle is secure and the lifting pads are still in contact with the frame. | <ul style="list-style-type: none"> Continue raising vehicle to desired height. Raise until the safety lock bars drop into the LOCKED position as described on Fig. A. Raise the lift to the desired height then lower the lift until the LOCK BARS rests against the LOCK BLOCK. <p>TO LOWER LIFT:</p> <ul style="list-style-type: none"> Clear area before lowering lift. Raise the lift until the release cam drops into the UNLOCKED position as described on Fig. B. Fully lower the lift and remove all lifting adapters before driving vehicle away. <p>WARNING</p> <p>ALWAYS ensure that the safety is in LOCKED position before any attempt is made to work on or near the vehicle.</p> | <p>SAFETY IN LOCKED POSITION (Release cam raised Lock Bar resting against Lock Block)</p> <p>Fig. A Release Cam Lock Bar Lock Block</p> <p>SAFETY IN UNLOCKED POSITION (Release cam lowered)</p> <p>Fig. B Release Cam Lock Bar Lock Block</p> | <p>WARNING</p> <p>Drive car completely over lift</p> <p>NEVER OVERLOAD LIFT Check for 1" minimum clearance between car and lift before raising.</p> <p>DO NOT park on, or load lift in a fully lowered position or damage may result.</p> <p>PH 100000</p> |
|--|---|--|---|

D

WARNING
VERY IMPORTANT
TO PROLONG LIFE EXPECTANCY OF CYLINDER SEALS AND PREVENT PREMATURE LEAKAGE AND WEAR, RAISE LIFT TO FULL HEIGHT AT LEAST ONCE A DAY. ALSO, THIS IS AN EFFECTIVE WAY TO BLEED ANY TRAPPED AIR AND MAINTAIN EQUAL LIFTING OF THE SYSTEM.

ATTENTION
TRÈS IMPORTANT
POUR PROLONGER L'ESPERANCE DE VIE DES JOINTS CYLINDRES ET PREVENIR LES FUITES PRÉMATURÉES ET PORTEZ, ÉLEVEZ LE PLEIN ÉLEVÉ HAUTEUR AU MOINS UNE FOIS PAR JOUR. AUSSI, C'EST UN EFFICACE FAÇON DE SAIGNER TOUT PIÉGÉ AIR ET MAINTIEN ÉGAL LEVAGE DU SYSTÈME.

PH 100000

E

BP BendPak. 1845 Lemmonwood Dr. Santa Paula, CA USA www.BendPak.com

LIFT TYPE: Surface Mount **MANUFACTURER:** BendPak. See data plate for product details

POWER: Electrical/Hydraulic **INSTALLATION:** See manual or contact factory

Safety Instructions: If attachments, accessories, or configuration modifying components that are located in the load path affect operation of the lift, affect the lift electrical testing, or affect intended vehicle accommodations are used on this lift and, if they are not certified for use on this lift, then the certification of this lift shall become null and void. Contact the participant for information pertaining to certified attachments, accessories, or configuration-modifying components.

BendPak lifts are supplied with concrete fasteners meeting the criteria as prescribed by ASTM E488/ E488M-16. Lift buyers are responsible for any special regional, structural, and/or seismic anchoring requirements specified by any other agencies and/or codes such as the Uniform Building Code (UBC) and/or International Building Code (IBC).

The manufacture, use, sale, or import of this product may be subject to one or more United States patents, or pending applications, owned by BendPak Inc.

Do Not Remove Engineered by BendPak Inc., USA PH 590037 Made in China

F

WARNING!

Maximum Lifting Capacity 6,000 lbs. / 2722 kg **WARNING!** Maximum Lifting Capacity 6,000 lbs. / 2722 kg

FAILURE TO READ AND UNDERSTAND THE FOLLOWING WARNINGS MAY RESULT IN PERSONAL INJURY AND/OR PROPERTY DAMAGE. KEEP HANDS AND FEET CLEAR FROM MOVING PARTS.

Read and understand entire contents of operation manual and warnings below before operating this equipment.

| | |
|--|---|
| <ul style="list-style-type: none"> ✓ Never exceed the rated capacity of the lift. ✓ Do not operate the lift if any component is found to be defective or worn. ✓ Never operate lift with any person or equipment below. ✓ Always ensure load is centered and stable prior to operating controls. ✓ When lowering the lift pay careful attention that all personnel and objects are kept clear. ✓ Always keep a visual line of site on the lift during operation. | <ul style="list-style-type: none"> ✓ Always stand clear of lift when lowering or raising. ✓ Never leave lift in elevated position unless safety lock is engaged in the LOCKED position. ✓ Keep all body parts and objects away from pinch points when lift is in motion. ✓ Use on level concrete in good condition and free of cracks or other defects. ✓ Visually confirm safety lock is properly engaged before working on or near lift. |
|--|---|

PH 100000

G

BP BendPak. Santa Paula, CA USA www.BendPak.com

MODEL NUMBER

DESCRIPTION

LIFT CAPACITY **DATE CODE**

| | |
|---|---|
| <p>VOLTAGE</p> <p><input type="checkbox"/> 110-120V, 50-60 Hz, 1 Ph</p> <p><input type="checkbox"/> 208-240V, 50-60 Hz, 1 Ph</p> <p><input type="checkbox"/> 380-415V, 50-60 Hz, 3 Ph</p> <p><input type="checkbox"/> 208-440V, 50-60 Hz, 3 Ph</p> | <p>SERIAL NUMBER</p> <hr/> <p>UPC</p> <hr/> |
|---|---|

DANGER!
Disconnect Power Before Servicing

ERC

MADE IN CHINA WARRANTY VOID IF DATA PLATE IS REMOVED PH 100000

H



LR-60P Tow Handle Assembly



ZIPTIE TO HANDLE

LR-60 Control Stand

ZIPTIE TO STAND



H

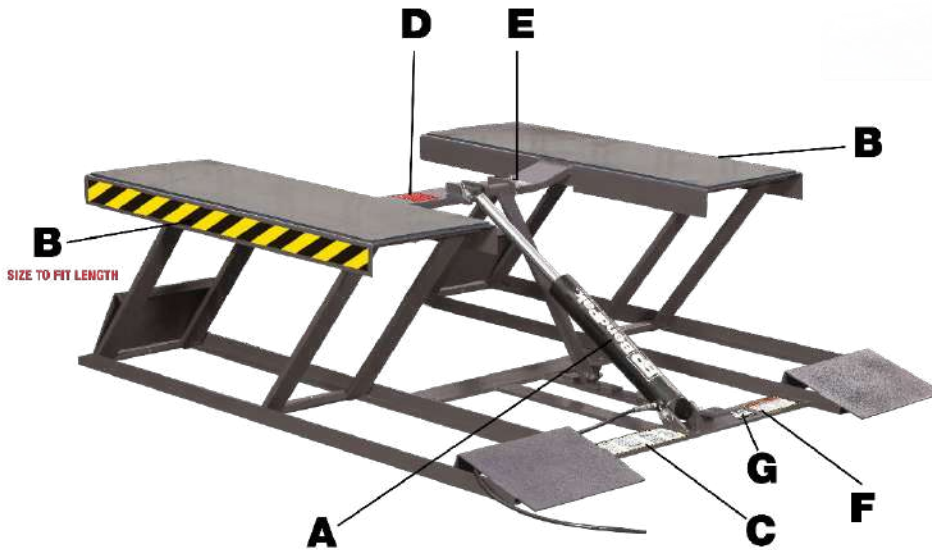

Parts Diagrams

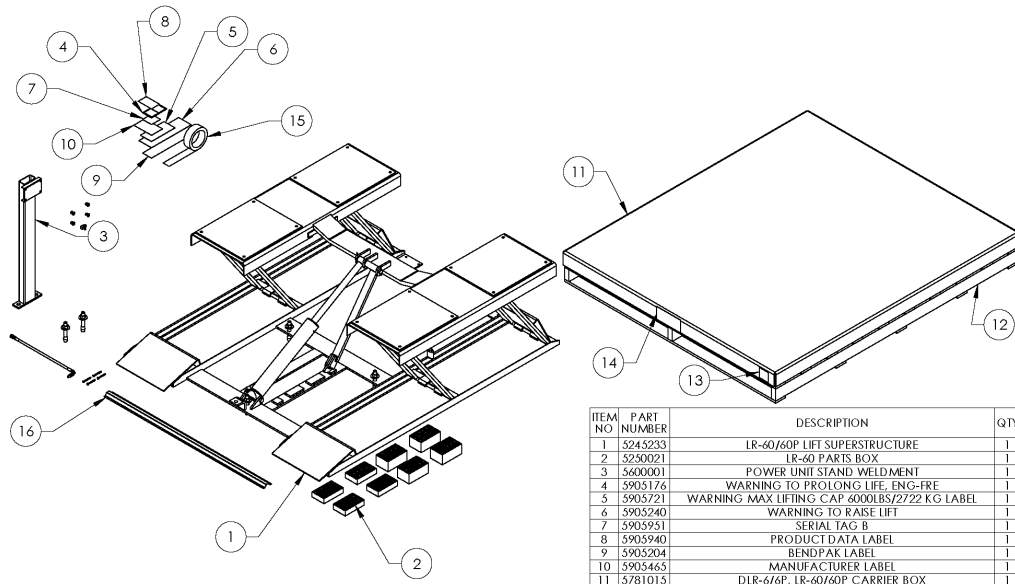

| ITEM NO | PART NUMBER | DESCRIPTION | QTY | REV |
|---------|-------------|---|-----|-----|
| 1 | 5245233 | LR-60/60P LIFT SUPERSTRUCTURE | 1 | M |
| 2 | 5250021 | LR-60 PARTS BOX | 1 | L |
| 3 | 5600001 | POWER UNIT STAND WELDMENT | 1 | A |
| 4 | 5905176 | WARNING TO PROLONG LIFE, ENG-FRE | 1 | - |
| 5 | 5905721 | WARNING MAX LIFTING CAP 6000LBS/2722 KG LABEL | 1 | - |
| 6 | 5905240 | WARNING TO RAISE LIFT | 1 | - |
| 7 | 5905951 | SERIAL TAG B | 1 | - |
| 8 | 5905940 | PRODUCT DATA LABEL | 1 | - |
| 9 | 5905204 | BENDPAK LABEL | 1 | - |
| 10 | 5905463 | MANUFACTURER LABEL | 1 | - |
| 11 | 5781013 | DLR-6/6P, LR-60/60P CARRIER BOX | 1 | A |
| 12 | 5940007 | DLR-6/6P, LR-60/60P PALLET ASSEMBLY | 1 | A |
| 13 | 5905285 | SERIALTAG EXTERIOR PEEL OFF INVENTORY LABEL | 1 | - |
| 14 | 5905970 | LR-60 PACKAGING LABEL | 1 | - |
| 15 | 5930609 | BLACK AND YELLOW HAZARD 2" x 10H | 1 | - |
| 16 | 5701656 | HYDRAULIC HOSE COVER 1372mm | 1 | A |

DO NOT SCALE DRAWING

| | | | |
|------------------------|----|------------|---|
| DRAWN | TM | 10/04/2010 | |
| CHECKED | OR | 4/14/2020 | |
| THIRD ANGLE PROJECTION | | | TITLE: LR-60 PRODUCTION LIFT VER A SEE DWG. NO. 5260167 REV Z |

SCALE: 1:25 SHEET 1 OF 3

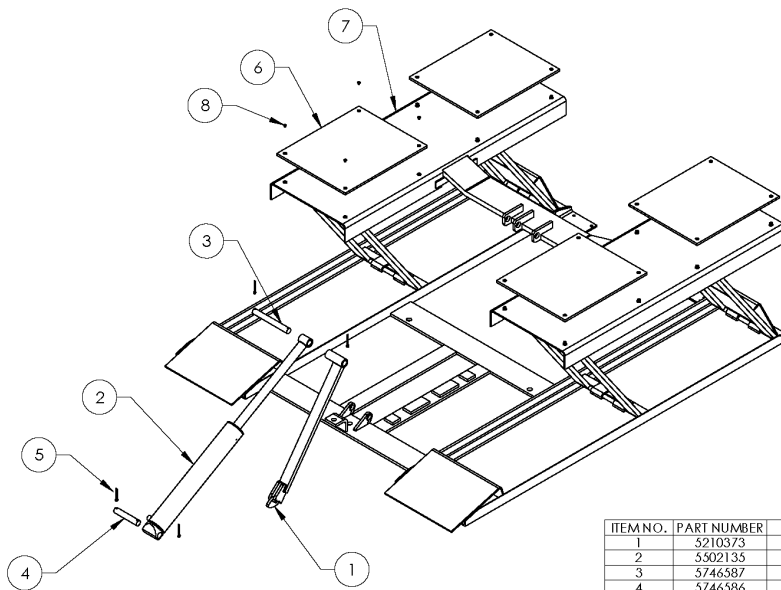

| ITEM NO. | PART NUMBER | DESCRIPTION | QTY. | REV |
|----------|-------------|--------------------------------|------|-----|
| 1 | 5210373 | LR-60/60P SAFETY BAR ASSEMBLY | 1 | D |
| 2 | 5502135 | CYLINDER ASSEMBLY Ø3.0 X 18 | 1 | D |
| 3 | 5746387 | UPPER HINGE PIN | 1 | B |
| 4 | 5746386 | DLR-6/LR-60 LOWER CYLINDER PIN | 1 | B |
| 5 | 5505400 | Ø6 x 50mm COILER PIN | 4 | - |
| 6 | 5715035 | RAMP BOLL-ON RUBBER PAD | 4 | A |
| 7 | 5600326 | LR-60 LIFT WELDMENT | 1 | K |
| 8 | 5530366 | FHSS M6 x 1.0 x 8 | 16 | - |

DO NOT SCALE DRAWING

| | | | |
|------------------------|----|------------|---|
| DRAWN | TM | 10/04/2010 | |
| CHECKED | CA | 11/1/2019 | |
| THIRD ANGLE PROJECTION | | | TITLE: LR-60/60P LIFT SUPERSTRUCTURE SIZE: DWG. NO. 5245233 REV M |

SCALE: 1:20 SHEET 1 OF 2

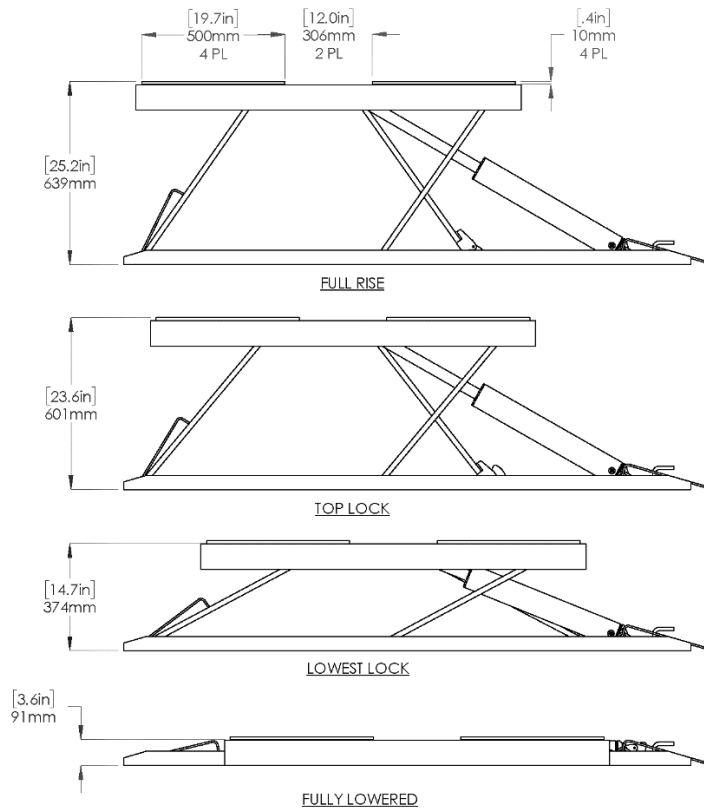

BendPak.
 1645 LEMONWOOD DR.
 SANTA PAULA, CA 93060

TITLE: LR-60/60P LIFT SUPERSTRUCTURE

SEE DWG. NO. **A** 5245233 REV **M**

SCALE: 1:20 SHEET 2 OF 2

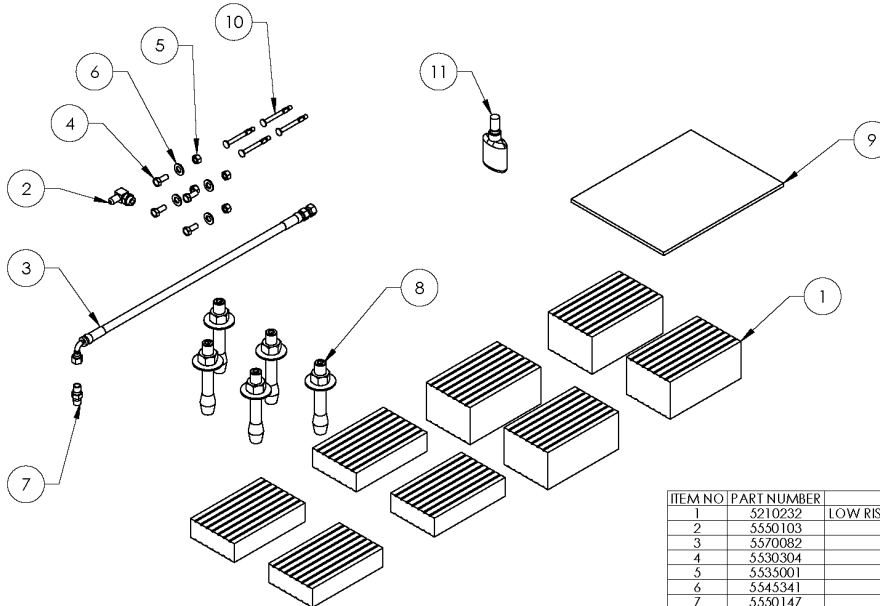

| ITEM NO. | PART NUMBER | DESCRIPTION | QTY | REV |
|----------|-------------|--|-----|-----|
| 1 | 5210232 | LOW RISE SCISSOR LIFT RUBBER PAD KIT, SET OF 8 | 1 | A |
| 2 | 5550103 | FTG ELB-04 JIC-06 ORB | 1 | - |
| 3 | 5570082 | HOSE ASSY Ø6.4 x 2873mm SB | 1 | A |
| 4 | 5530304 | HHB M8 x 1.25 x 20 | 4 | - |
| 5 | 5535001 | NUT M8 x 1.25 NL | 4 | - |
| 6 | 5545341 | WASHER M10 x Ø20 FLAT | 4 | - |
| 7 | 5550147 | FTG NPL-04 JIC x-04 NPT | 1 | - |
| 8 | 5530456 | AB 3/4" x 4 - 3/4" | 5 | - |
| 9 | 5900337 | LR-60/60P INSTALLATION MANUAL | 1 | - |
| 10 | 5530365 | AB 1/4" x 2 1/2" DRIVE | 4 | - |
| 11 | 5580012 | LIQUID PTFE THREAD SEALANT 50ml | 1 | - |

DO NOT SCALE DRAWING

NAME: TM DATE: 10/04/2010

DRAWN: TM 10/04/2010

CHECKED: OR 04/03/2020

THIRD ANGLE PROJECTION

DIMENSIONS ARE IN MM

BendPak.
 1645 LEMONWOOD DR.
 SANTA PAULA, CA 93060

TITLE: LR-60 PARTS BOX

SEE DWG. NO. **A** 5250021 REV **L**

SCALE: 1:8 SHEET 1 OF 1

PROPRIETARY AND CONFIDENTIAL
 THE INFORMATION CONTAINED IN THIS DRAWING IS THE SOLE PROPERTY OF BENDPAK INC. ANY REPRODUCTION IN PART OR AS A WHOLE WITHOUT THE WRITTEN PERMISSION OF BENDPAK INC. IS PROHIBITED.

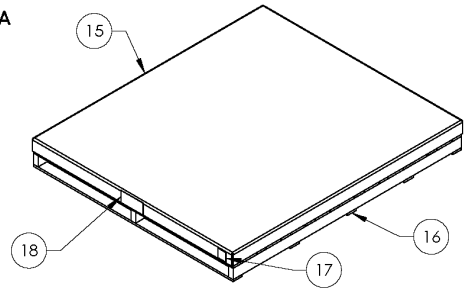
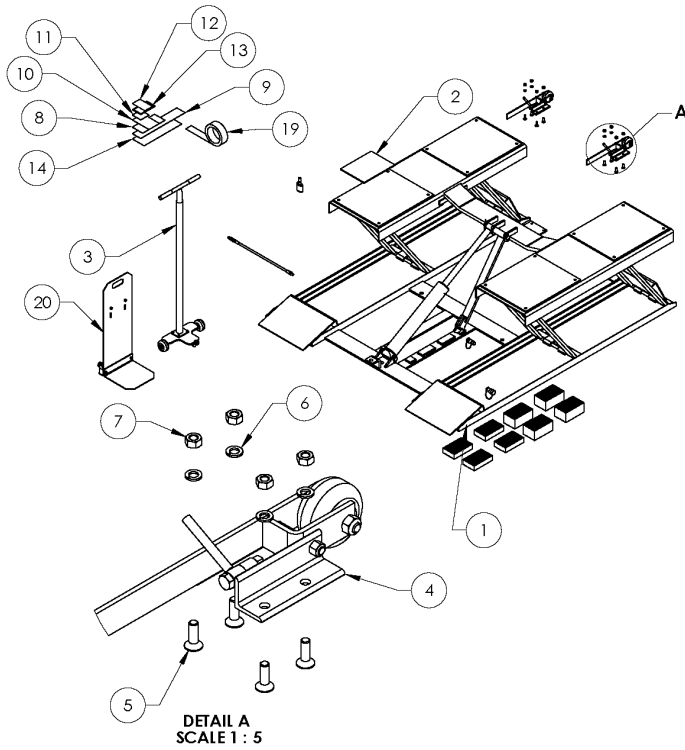

| ITEM NO | PART NUMBER | DESCRIPTION | QTY | REV |
|---------|-------------|---|-----|-----|
| 1 | 5245233 | LR-60/60P LIFT SUPERSTRUCTURE | 1 | M |
| 2 | 5230020 | LR-60P PARTS BOX | 1 | N |
| 3 | 5215871 | LOW RISE TOW CART ASSEMBLY | 1 | B |
| 4 | 5210907 | LR-60P WHEEL BRACKET ASSEMBLY | 2 | C |
| 5 | 5530004 | FHP'S M10 x 1.5 x 30 | 8 | - |
| 6 | 5545200 | WASHER M10 x Ø18 FL | 8 | - |
| 7 | 5535998 | NUT M10 x 1.5 | 8 | - |
| 8 | 5905721 | WARNING MAX LIFTING CAP 6000LBS/2722 KG LABEL | 1 | - |
| 9 | 5905204 | BENDPAK LABEL | 1 | - |
| 10 | 5905465 | MANUFACTURER LABEL | 1 | - |
| 11 | 5905951 | SERIAL TAG B | 1 | - |
| 12 | 5905940 | PRODUCT DATA LABEL | 1 | - |
| 13 | 5905176 | WARNING TO PROLONG LIFE, ENG-FRE | 1 | - |
| 14 | 5905240 | WARNING TO RAISE LIFT | 1 | - |
| 15 | 5781013 | LR-60/60P CARRIER BOX | 1 | A |
| 16 | 5940007 | LR-60/60P PALLET ASSEMBLY | 1 | A |
| 17 | 5905285 | SERIAL TAG EXTERIOR PEEL OFF INVENTORY LABEL | 1 | - |
| 18 | 5905971 | LR-60P PACKAGING LABEL | 1 | - |
| 19 | 5930609 | BLACK AND YELLOW HAZARD 2" x 10" | 1 | - |
| 20 | 5215983 | LOW RISE WHEELED POWER UNIT STAND ASSEMBLY | 1 | A |

DO NOT SCALE DRAWING

NAME: TM DATE: 10/05/2010

CHECKED:

DIMENSIONS ARE IN MM

THIRD ANGLE PROJECTION

PROPRIETARY AND CONFIDENTIAL
THE INFORMATION CONTAINED IN THIS DRAWING IS THE SOLE PROPERTY OF BENDPAK INC. ANY REPRODUCTION IN PART OR AS A WHOLE WITHOUT THE WRITTEN PERMISSION OF BENDPAK INC. IS PROHIBITED.

BendPak
1645 LEMONWOOD DR.
SANTA PAULA, CA 93060

TITLE: LR-60/60P PRODUCTION LIFT VER A

SIZE DWG. NO. REV
A 5260168 AB

SCALE: 1:30 SHEET 1 OF 3

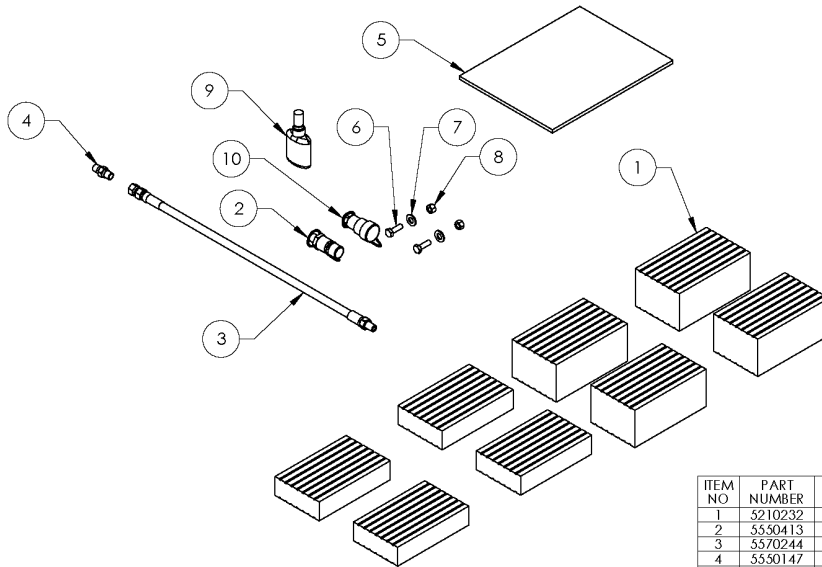

| ITEM NO | PART NUMBER | DESCRIPTION | QTY | REV |
|---------|-------------|---|-----|-----|
| 1 | 5210232 | LOW RISE SCISSOR LIFT RUBBER PAD KIT, SET OF 8 | 1 | A |
| 2 | 5550413 | FIG NPL-06 ORB x 1/4 NS, QUICK-CON COUPL MALE | 1 | A |
| 3 | 5570244 | HYDRAULIC HOSE ASSEMBLY Ø6.4 x 2873mm DS-M | 1 | A |
| 4 | 5550147 | FIG NPL-04 JIC x-04 NPT | 1 | - |
| 5 | 5900337 | LR-60/60P INSTALLATION MANUAL | 1 | - |
| 6 | 5530010 | HHB M8 x 1.25 x 25 | 2 | - |
| 7 | 5545341 | WASHER M10 x Ø20 FLAT | 2 | - |
| 8 | 5535001 | NUT M8 x 1.25 NL | 2 | - |
| 9 | 5580012 | LIQUID PTFE THREAD SEALANT 50ml | 1 | - |
| 10 | 5550031 | FIG NPL-04 NPT F x 1/4 QUICK-CONNECTOR COUPLER FEMALE; NON SPILL DESIGN | 1 | - |

DO NOT SCALE DRAWING

NAME: TM DATE: 10/05/2010

CHECKED:

DIMENSIONS ARE IN MM

THIRD ANGLE PROJECTION

PROPRIETARY AND CONFIDENTIAL
THE INFORMATION CONTAINED IN THIS DRAWING IS THE SOLE PROPERTY OF BENDPAK INC. ANY REPRODUCTION IN PART OR AS A WHOLE WITHOUT THE WRITTEN PERMISSION OF BENDPAK INC. IS PROHIBITED.

BendPak
1645 LEMONWOOD DR.
SANTA PAULA, CA 93060

TITLE: LR-60/60P PARTS BOX

SIZE DWG. NO. REV
A 5250020 N

SCALE: 1:6 SHEET 1 OF 1

Automotive Lift Institute (ALI) Store

You probably checked the **ALI's Directory of Certified Lifts** (www.autolift.org/ali-directory-of-certified-lifts/) before making your most recent Lift purchase, but did you know the **ALI Store** (www.autolift.org/ali-store/) offers a wide variety of professional, easy-to-use, and reasonably priced training and safety materials that will make your garage a safer place to work?

The ALI Store is your trusted source for workplace safety!



Lifting It Right Online Certificate Course. Make *sure* you and your people are lifting vehicles the right way.



ALI Lift Inspector Certification Program Registration. Become an ALI Certified Lift Inspector.



ANSI/ALI ALOIM Standard for Automotive Lifts. Safety Requirements for Operation, Inspection, and Maintenance.

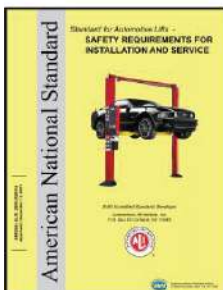

ANSI/ALI ALIS Standard. Safety Requirements for Installation and Service.

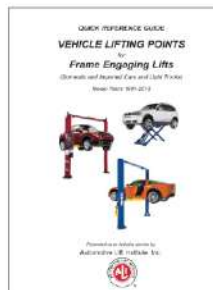

Guide to Hitting Vehicle Lifting Points for Frame-Engaging Lifts. Don't eyeball your lifting points, *know* where they are.



Lift Operator Safety Materials. Five safety documents in a single package.

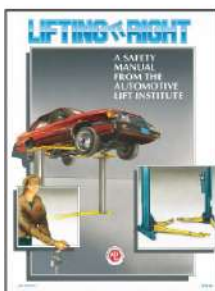

Lifting It Right. A hardcopy version of the *Lifting It Right* safety manual from the Automotive Lift Institute.



Uniform Warning Labels and Placards for 2-Posts. Labels in Mandarin, French Canadian, and Spanish are also available.



Safety Tips Card. Reminds your people of 13 key safety tips to follow daily.

Visit today and get the training and materials you need to work safely:
<http://www.autolift.org/ali-store/>.



1645 Lemonwood Drive
Santa Paula, CA 93060 USA