



Operating Instructions and Parts Manual Drum Sander

Models JWDS-1632, JWDS-1836



Model JWDS-1632 shown with optional infeed/outfeed tables

JET
427 New Sanford Road
LaVergne, Tennessee 37086
Ph.: 800-274-6848
www.jettools.com

Part No. M-723520
Edition 4 03/2019
Copyright © 2016 JET



1.0 IMPORTANT SAFETY INSTRUCTIONS

WARNING – To reduce risk of injury:

1. Read and understand the entire owner's manual before attempting assembly or operation.
2. Read and understand the warnings posted on the machine and in this manual. Failure to comply with all of these warnings may cause serious injury.
3. Replace warning labels if they become obscured or removed.
4. This drum sander is designed and intended for use by properly trained and experienced personnel only. If you are not familiar with the proper and safe operation of a drum sander, do not use until proper training and knowledge have been obtained.
5. Do not use this drum sander for other than its intended use. If used for other purposes, JET disclaims any real or implied warranty and holds itself harmless from any injury that may result from that use.
6. Always wear ANSI Z87.1 approved safety glasses or face shield while using this drum sander. (Everyday eyeglasses only have impact resistant lenses; they are *not* safety glasses.)
7. Before operating this machine, remove tie, rings, watches and other jewelry, and roll sleeves up past the elbows. Do not wear loose clothing. Confine long hair. Non-slip footwear or anti-skid floor strips are recommended. Do not wear gloves.
8. Kickback occurs when the workpiece is thrown towards the operator at a high rate of speed. If you do not have a clear understanding of kickback and how it occurs, DO NOT operate this drum sander.
9. Wear hearing protection (plugs or muffs) during extended periods of operation.
10. Do not operate this machine while tired or under the influence of drugs, alcohol or any medication.
11. Make certain the switch is in the OFF position before connecting the machine to the power supply.
12. Make certain the machine is properly grounded.
13. Make all machine adjustments or maintenance with the machine unplugged from the power source.
14. Remove adjusting keys and wrenches. Form a habit of checking to see that keys and adjusting wrenches are removed from the machine before turning it on.
15. Keep safety guards in place at all times when the machine is in use. If removed for maintenance purposes, use extreme caution and replace the guards immediately after completion of maintenance.
16. Make sure the sander is firmly secured to the stand or work table before use.
17. Check damaged parts. Before further use of the machine, a guard or other part that is damaged should be carefully checked to determine that it will operate properly and perform its intended function. Check for alignment of moving parts, binding of moving parts, breakage of parts, mounting and any other conditions that may affect its operation. A guard or other part that is damaged should be properly repaired or replaced.
18. Provide for adequate space surrounding work area and non-glare, overhead lighting.
19. Keep the floor around the machine clean and free of scrap material, oil and grease.
20. Keep visitors a safe distance from the work area. Keep children away.
21. Make your workshop child proof with padlocks, master switches or by removing starter keys.
22. Give your work undivided attention. Looking around, carrying on a conversation and "horse-play" are careless acts that can result in serious injury.
23. Maintain a balanced stance at all times so that you do not fall onto moving parts. Do not overreach or use excessive force to perform any machine operation.
24. Use the right tool at the correct speed and feed rate. Do not force a tool or attachment to do a job for which it was not designed. The right tool will do the job better and more safely.
25. Use recommended accessories; improper accessories may be hazardous.
26. Maintain tools with care. Keep conveyor and abrasives clean for the best and safest performance. Follow instructions for lubricating and changing accessories.
27. Turn off the machine before cleaning. Use a brush or compressed air to remove chips or debris — do not use bare hands.
28. Do not stand on the machine. Serious injury could occur if the machine tips over.

29. Never leave the machine running unattended. Turn the power off and do not leave the machine until it comes to a complete stop.
30. Remove loose items and unnecessary work pieces from the area before starting the machine.
31. Stand out of the path of workpiece when feeding a board.
32. Always feed stock against the rotation of drum.
33. Keep hands clear when feeding parts onto the conveyor. The part will be forced down as it begins to feed, causing a pinching action between the part and the conveyor table. Never reach into a running machine. Turn off sander, allow it to come to a complete stop, and disconnect from power, before attempting to retrieve parts from beneath the drum.
34. Pay particular attention to instructions on reducing risk of kickback.
35. Don't use in dangerous environment. Don't use power tools in damp or wet location, or expose them to rain. Keep work area well lighted.

⚠ WARNING: This product can expose you to chemicals including lead which is known to the State of California to cause cancer and birth defects or other reproductive harm. For more information go to <http://www.p65warnings.ca.gov>.

⚠ WARNING: Drilling, sawing, sanding or machining wood products generates wood dust and other substances known to the State of California to cause cancer. Avoid inhaling dust generated from wood products or use a dust mask or other safeguards for personal protection.

Wood products emit chemicals known to the State of California to cause birth defects or other reproductive harm. For more information go to <http://www.p65warnings.ca.gov/wood>.

Familiarize yourself with the following safety notices used in this manual:

⚠ CAUTION This means that if precautions are not heeded, it may result in minor injury and/or possible machine damage.

⚠ WARNING This means that if precautions are not heeded, it may result in serious, or possibly even fatal, injury.

2.0 About this manual

This manual is provided by JET, covering the safe operation and maintenance procedures for a JET Model JWDS-1632 and JWDS-1836 Drum Sander. This manual contains instructions on installation, safety precautions, general operating procedures, maintenance instructions and parts breakdown. Your machine has been designed and constructed to provide consistent, long-term operation if used in accordance with the instructions as set forth in this document.

This manual is not intended to be an exhaustive guide to sanding methods, choice of stock, selection of abrasives, etc. Additional knowledge may be obtained from experienced users or trade articles. Whatever accepted methods are used, always make personal safety a priority.

If there are questions or comments, please contact your local supplier or JET. JET can also be reached at our web site: www.jettools.com.

Retain this manual for future reference. If the machine transfers ownership, the manual should accompany it.

Use the provided mail-in card, or register your product online - <http://www.jettools.com/us/en/service-and-support/warranty/registration/>

⚠ WARNING Read and understand the entire contents of this manual before attempting assembly or operation! Failure to comply may cause serious injury!

3.0 Table of contents

Section	Page
1.0 IMPORTANT SAFETY INSTRUCTIONS	2
2.0 About this manual	3
3.0 Table of contents	4
4.0 Specifications	5
5.0 Features and Terminology	6
6.0 Setup and assembly	7
6.1 Shipping contents	7
6.2 Tools required for assembly	7
6.3 Assembling stand	8
6.4 Mounting sander to stand	8
6.5 Infeed and outfeed tables (optional accessory)	9
6.6 Dust collection	9
6.7 Installing abrasives	9
7.0 Electrical connections	10
7.1 GROUNDING INSTRUCTIONS	10
7.2 Extension cords	11
8.0 Adjustments	11
8.1 Drum Height Control	11
8.2 Depth scale	11
8.3 Conveyor belt tension/tracking	12
8.4 Inspecting drum alignment	12
8.5 Tension roller adjustment	13
9.0 Operations	13
9.1 Basic Operating Procedure	13
9.2 Switch safety key	14
9.3 Setting depth of cut	14
9.4 Establishing drum height	14
9.5 Selecting SandSmart™ feed rates	14
9.6 Maximum performance tips	15
10.0 User-maintenance	16
10.1 Cleaning and lubrication	16
10.2 Drum maintenance	16
10.3 Conveyor belt replacement	16
10.4 Commutator brush inspection	17
10.5 Additional servicing	17
11.0 Tracker kit	18
12.0 Abrasives	19
12.1 Selecting drum abrasives	19
12.2 Cleaning abrasive strips	19
12.3 Increasing abrasive life	19
12.4 Abrasive selection guide	19
13.0 Troubleshooting JWDS-series Drum Sander	20
14.0 Optional accessories	22
15.0 Replacement Parts	22
15.1.1 JWDS-1632/-1836 Head Assembly – Exploded View	23
15.1.2 JWDS-1632/-1836 Head Assembly – Parts List	24
15.2.1 JWDS-1632/-1836 Conveyor Table Assembly – Exploded View	26
15.2.2 JWDS-1632/-1836 Conveyor Table Assembly – Parts List	26
15.3.1 JWDS-1632/-1836 Infeed and Outfeed Tables (OPTIONAL) – Exploded View	27
15.3.2 JWDS-1632/-1836 Infeed and Outfeed Tables (OPTIONAL) – Parts List	27
15.4.1 JWDS-1632/-1836 Open Stand Assembly – Exploded View	28
15.4.2 JWDS-1632/-1836 Open Stand Assembly – Parts List	28
16.0 Electrical Connections for JWDS-1632/-1836	29
17.0 Warranty and service	30

4.0 Specifications

Model number **JWDS-1632** **JWDS-1836**

Stock numbers:

Sander with open stand 723520K 723530K
 Sander only 723520B 723530B
 Open stand only 723520S 723520S

Motor and electricals:

Drum motor:

Motor type totally enclosed fan cooled, induction, capacitor start
 Horsepower 1-1/2 HP 1-3/4 HP
 Phase single single
 Voltage 115V only 115V only
 Cycle 60Hz 60Hz
 Listed FLA (full load amps) 14 A 15 A
 Motor speed 1725 RPM 1725 RPM
 Starting amps 32 A 43 A
 Running amps (no load) 9.5 A 6.8 A
 Start capacitor 300MFD 125VAC 300MFD 125VAC
 Running capacitor n/a 50µF 250VAC

Conveyor motor:

Motor type totally enclosed DC totally enclosed DC
 Horsepower 1/30 HP 1/30 HP
 Phase single single
 Voltage 115V DC 115V DC
 Listed FLA (full load amps) 0.60 A 0.60 A
 Motor speed 54 RPM 54 RPM
 On/off switch toggle, with safety key toggle, with safety key
 Power cord 12AWG x 3C, 6 ft. (1830 mm) 12AWG x 3C, 6 ft. (1830 mm)
 Power plug installed 125V 15A 125V 15A
 Recommended circuit and fuse/breaker size ¹ 20A 20A
 Sound emission ² 63 dB at 100cm; 66 dB at 50cm 71 dB at 100cm; 75 dB at 50cm

Capacities:

Maximum board width (single pass) 16 in. (406 mm) 18 in. (457 mm)
 Maximum board width (two passes) 32 in. (812 mm) 36 in. (914 mm)
 Maximum board thickness 3 in. (76.2 mm) 3 in. (76.2 mm)
 Minimum board length 2-3/8 in. (60 mm) 2-3/8 in. (60 mm)
 Minimum board thickness ³ 1/32 in. (0.8 mm) 1/32 in. (0.8 mm)

Main materials:

Main body aluminum die casting and steel aluminum die casting and steel
 Open stand steel steel
 Drum extruded aluminum extruded aluminum
 Extension tables (optional) steel steel
 Conveyor table steel steel
 Drum height adjustment handle plastic plastic

Sanding drum:

Drum dimensions dia. 5 in. x 16L (127 x 406 mm) dia. 5 in. x 18L (127 x 457 mm)
 Drum speed 1725 RPM 1725 RPM
 Sanding paper installed 80 grit 80 grit
 Drum elevation per one rotation of handwheel 1/16 in. 1/16 in.

¹ Subject to local/national electrical codes.

² The specified values are emission levels and are not necessarily to be seen as safe operating levels. As workplace conditions vary, this information is intended to allow the user to make a better estimation of the hazards and risks involved only.

³ Use of a carrier or backer board (not provided) is recommended for cuts 1/16" or less. See sect. 9.3.

Conveyor:

Conveyor speed.....	infinitely variable within 0 to 10 FPM (0-3 MPM).....
Conveyor table dimensions.....	17-15/16 x 16-17/32 in. (456 x 420 mm)
Conveyor height from floor.....	31-31/32 in. (812 mm)

Dust collection:

Dust port outside diameter.....	4 in. (100mm).....	4 in. (100mm)
Minimum extraction volume required	400 CFM (11.3 CMM).....	400 CFM (11.3 CMM)

Dimensions:

Shipping carton, base machine.....	38-25/32 x 22-7/16 x 20-1/16 in. (985 x 570 x 510 mm)
Shipping carton, open stand.....	33-7/8 x 16-3/8 x 4-3/4 in. (860 x 415 x 120 mm)
Assembled dimensions.....	20 x 49-15/16 x 39-5/8 in. (508 x 1269 x 1007 mm).....

Weights:

Net weight.....	156 lb. (71 kg).....	164 lb. (75 kg)
Shipping weight	182 lb. (83 kg).....	190 lb. (87 kg)

The specifications in this manual were current at time of publication, but because of our policy of continuous improvement, JET reserves the right to change specifications at any time and without prior notice, without incurring obligations.

5.0 Features and Terminology

The illustration below shows the major components and features of the JWDS-series Sanders. These are referenced throughout the manual and will help to familiarize you with the operation and functions of the machine.

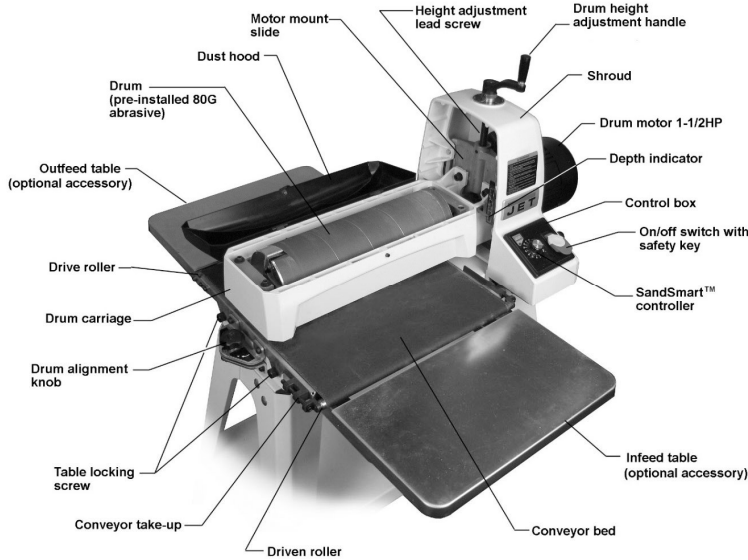

Figure 5-1

⚠WARNING Read and understand the entire contents of this manual before attempting set-up or operation! Failure to comply may cause serious injury.

6.0 Setup and assembly

Open boxes and check for shipping damage. Report any damage immediately to your distributor and shipping agent. Do not discard any shipping material until the Drum Sander is assembled and running properly.

Compare the contents of your boxes with the following parts list to make sure all parts are intact. Any missing parts should be reported to your distributor. Read this instruction manual thoroughly for assembly, maintenance and safety instructions.

6.1 Shipping contents

Box #1: (see Figure 6-1)

- 1 Sander with conveyor table (A)
- 1 Handle (B)
- 1 Instruction manual (not shown)
- 1 Warranty card (not shown)

Box #2: (see Figure 6-2)

- 1 Stand assembly including:
 - 1 Shelf (C)
 - 2 Short rails (D)
 - 2 Long rails (E)
 - 4 Legs (F)
 - 4 Leveling feet (G)
 - 8 Flat washers (H)
 - 4 Hex nuts (I)
 - 24 Carriage Bolts, M8x16 (J)
 - 24 Flanged Lock Nuts, M8 (K)

6.2 Tools required for assembly

12mm and 14mm wrenches
 3mm and 6mm hex wrenches
 Straight edge (such as straight steel bar or carefully jointed board)

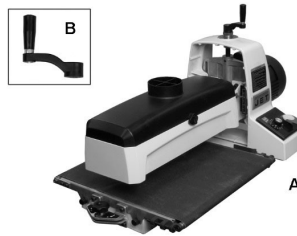

Figure 6-1: box #1 (main unit)

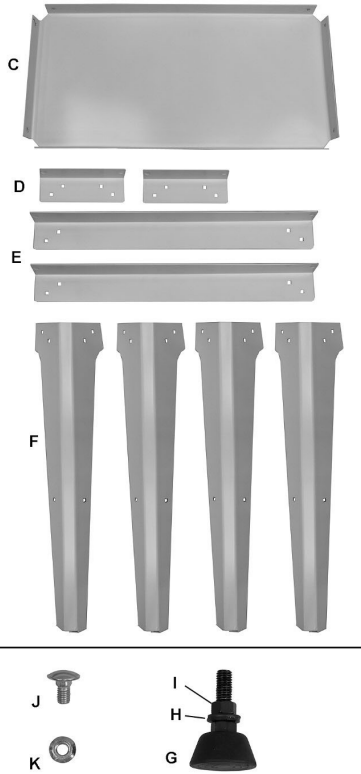

Figure 6-2: box #2 (stand assembly)

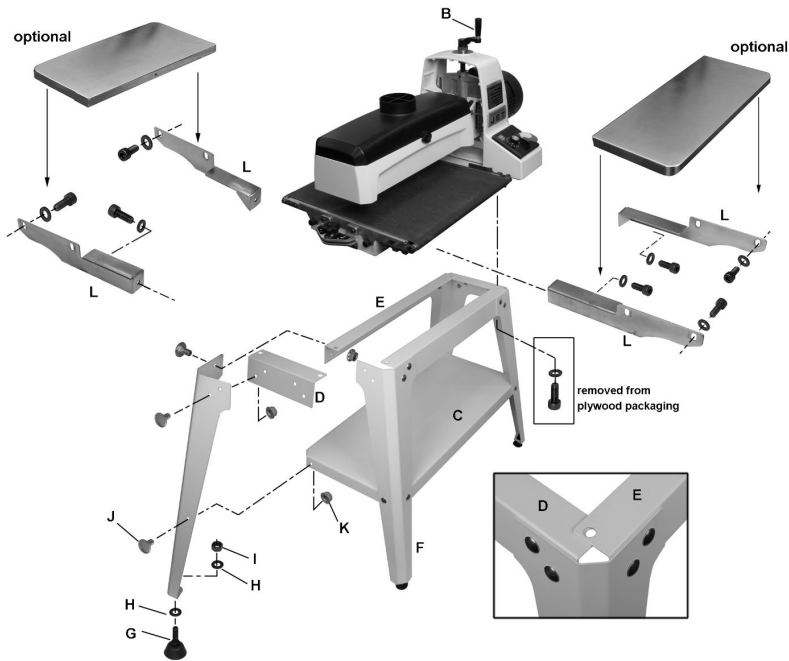

Figure 6-3: Assembly

6.3 Assembling stand

(Refer to Figure 6-3. If further clarification is needed, consult parts breakdown at back of this manual.)

1. Assemble legs (F) to outside of Short Rails (D) using carriage bolts (J) and flanged lock nuts (K). *Finger tighten only.*
2. Assemble Long Rail (E) on inside of legs and on top of Short Rails (D). *Finger tighten only.* NOTE: Flange of Long Rail overlaps flange of Short Rail. See inset, Figure 6-3.
3. Turn stand upside down. Install shelf (C) into legs using carriage bolts and lock nuts.
4. Fully tighten all flanged lock nuts in shelf and legs.
5. Insert leveling foot (G) into bottom hole of leg with flat washers and hex nut.
6. Turn stand right-side up, and push down on it to settle it. Tighten all flanged lock nuts on stand.
7. Level the stand using the leveling feet. Tighten the hex nuts against the leg flange.

6.4 Mounting sander to stand

1. Lift drum head assembly out of the box, and temporarily rest it crosswise on top of stand.

⚠WARNING Use an assistant to help lift the sander.
2. Install height adjustment handle (B), and tighten set screw.
3. Rotate height adjustment handle counter-clockwise to raise drum and free the wood support block.
4. Remove the socket head cap screws and washers which secure the plywood boards to the bottom of sander base. Retain these screws and washers for step 6.

- Position sander atop stand so that the four threaded holes of base align with holes in the stand rails (Figure 6).
- Fasten base to stand (from beneath) with the four screws and washers that you removed from the plywood boards. Tighten screws securely.

6.5 Infeed and outfeed tables (optional accessory)

The sander must be bolted to the stand or a work table when using these table extensions. Maximum working load of each table is 35 pounds. Fasteners are provided with the extension tables.

- Install infeed and outfeed brackets (L, Figure 6-3) to the threaded holes in sander base with M8x16 socket head cap screws and flat washers. Make sure left and right brackets are oriented as shown. The brackets should be flush against the base. NOTE: Long brackets mount to front (infeed); short brackets to rear (outfeed).
- Place extension tables over brackets and secure with M8x12 socket head cap screws and washers. *Finger tighten only.*
- Position tables slightly below conveyor belt surface for proper support of stock. To check position, place a straight-edge on one side of conveyor table under drum and extending out over the extension table. Lower drum to securely hold straight-edge in place. See Figure 6-4. Raise infeed/outfeed table until table surface is slightly below conveyor belt surface. Tighten screws on that side.
- Reposition straight-edge to other side of table and repeat.

If stock being sanded is bowed, warped or otherwise inconsistent, be sure tables are lower than top of conveyor table.

If stock slips on conveyor, the tables may be positioned too high. Lower tables to allow stock to remain in contact with conveyor.



Figure 6-4: extension table alignment

6.6 Dust collection

Dust collection is mandatory for a safe work environment and extended abrasive life. The JWDS-1632/1836 is equipped with a 4-inch dust collection port. Secure a 4-inch dust collection hose to the port with a hose clamp (Figure 6-5), and connect to a high volume dust collector (minimum 400 CFM). *Note: Dryer vent hose is not acceptable for this purpose.*

A standard shop type canister (16 gal. or larger) can be used for short periods of sanding time but requires converting the hose size down to 2-1/2". An adaptor is required.

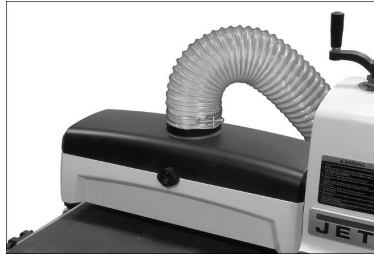

Figure 6-5 (hose and clamp not included)

6.7 Installing abrasives

Proper attachment of the abrasive strip to the drum is critical to achieving top performance from your drum sander.

An 80-grit, 3-inch wide abrasive strip is pre-installed on the drum. Optional pre-cut ("Ready-to-Wrap") abrasives of different grits are also available; see sect. 14.0.

(TIP: If you are using an after-market abrasive, use a new JET-supplied abrasive as a template to quickly cut a new strip. Alternatively, a diagram is supplied in Figures 6-6 and 6-7 showing trim measurements.)

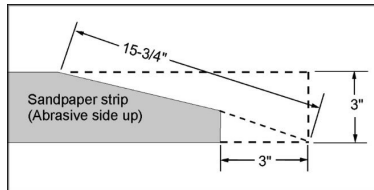

Figure 6-6: abrasive trimming – JWDS-1632 ONLY (not applicable to Ready-to-Wrap strips)

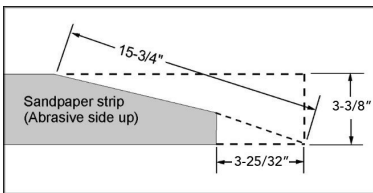

Figure 6-7: abrasive trimming – JWDS-1836 ONLY

1. Press fastener lever (Figure 6-8) on outboard (left) end of drum, and insert tapered end of abrasive through slit in fastener, as shown. Align tapered edge of abrasive strip with left edge of drum. Insert enough strip so that the right edge aligns with the reference notch; this will ensure the proper length of strip to be secured at the opposite end of the drum.

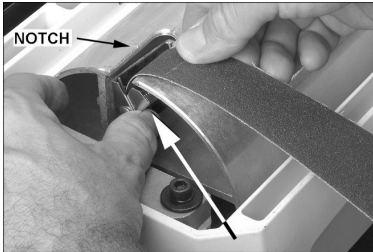

Figure 6-8

2. Release fastener lever to secure end of strip.
3. Begin wrapping abrasive around drum. The tapered edge of strip end should follow as close as possible to edge of drum.
4. Continue to wrap abrasive in spiral fashion by rotating drum with one hand and guiding strip with the other. See Figure 6-9.

Successive windings of strip must *not* have any overlap. They should be flush with previous windings or with a slight gap between.



Figure 6-9

5. Press inboard take-up lever (Figure 6-10) and insert trailing end of strip as far as it will go. If necessary, trim tapered end of abrasive strip.
6. Release inboard take-up lever to secure strip.

All abrasive strips will stretch over time as they are used, and may stretch enough to allow the take-up lever to reach its lowest position so that it cannot maintain tension on the strip. If this occurs, follow the above procedures to reset the take-up lever.

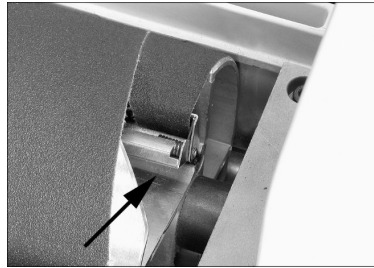

Figure 6-10

7.0 Electrical connections

⚠ WARNING All electrical connections must be done by a qualified electrician in compliance with all local codes and ordinances. Failure to comply may result in serious injury.

The JWDS-1632 and JWDS-1836 Sander are rated at 115-volt power only. The sander comes with a plug designed for use on a circuit with a *grounded outlet* that looks like the one pictured in Figure 17.

Before connecting to power source, be sure switch is in *off* position.

It is recommended that the sander be connected to a dedicated 20 amp circuit with circuit breaker or fuse. If connected to a circuit protected by fuses, use time delay fuse marked "D". **Local codes take precedence over recommendations.**

7.1 GROUNDING INSTRUCTIONS

This machine must be grounded. In the event of a malfunction or breakdown, grounding provides a path of least resistance for electric current to reduce the risk of electric shock. This tool is equipped with an electric cord having an equipment-grounding conductor and a grounding plug. The plug must be plugged into a matching outlet that is properly installed and grounded in accordance with all local codes and ordinances.

Do not modify the plug provided - if it will not fit the outlet, have the proper outlet installed by a qualified electrician.

Improper connection of the equipment-grounding conductor can result in a risk of electric shock. The conductor with insulation having an outer surface that is green with or without yellow stripes is the equipment-grounding conductor.

If repair or replacement of the electric cord or plug is necessary, do not connect the equipment-grounding conductor to a live terminal.

⚠WARNING Check with a qualified electrician or service personnel if the grounding instructions are not completely understood, or if in doubt as to whether the tool is properly grounded. Failure to comply may cause serious or fatal injury.

Use only 3-wire extension cords that have 3-prong grounding plugs and 3-pole receptacles that accept the tool's plug.

Repair or replace damaged or worn cord immediately.

This tool is intended for use on a circuit that has an outlet that looks like the one illustrated in Figure 7-1. An adapter, shown in Figure 7-2, may be used to connect this plug to a 2-pole receptacle as shown in Figure 7-2 if a properly grounded outlet is not available. The temporary adapter should be used only until a properly grounded outlet can be installed by a qualified electrician. The green-colored rigid ear, lug, and the like, extending from the adapter must be connected to a permanent ground such as a properly grounded outlet box.

In Canada, the use of a temporary adaptor is not permitted by the Canadian Electrical Code, C22.1.

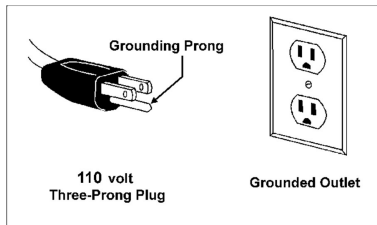

Figure 7-1

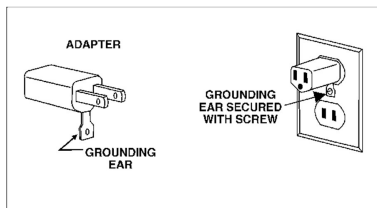

Figure 7-2

7.2 Extension cords

The use of extension cords is discouraged; try to position machines near the power source. If an extension cord is necessary, make sure it is in good condition. When using an extension cord, be sure to use one heavy enough to carry the current your product will draw. An undersized cord will cause a drop in line voltage resulting in loss of power and overheating. Table 1 shows correct size to use depending on cord length and nameplate ampere rating. If in doubt, use the next heavier gauge. The smaller the gauge number, the heavier the cord.

Recommended Gauges (AWG) of Extension Cords

Amps	Extension Cord Length *					
	25 feet	50 feet	75 feet	100 feet	150 feet	200 feet
< 5	16	16	16	14	12	12
5 to 8	16	16	14	12	10	NR
8 to 12	14	14	12	10	NR	NR
12 to 15	12	12	10	10	NR	NR
15 to 20	10	10	10	NR	NR	NR
21 to 30	10	NR	NR	NR	NR	NR

*based on limiting the line voltage drop to 5V at 150% of the rated amperes.

NR: Not Recommended.

Table 1

8.0 Adjustments

⚠WARNING Disconnect sander from power source before making adjustments.

8.1 Drum Height Control

Drum height and depth of cut are controlled by height adjustment handle (see Figure 5-1). Rotating handle clockwise lowers drum, counterclockwise raises it. One revolution of handle will move drum approximately 1/16" (or 1/4 turn = approx. 1/64"), as shown on the label below handle.

8.2 Depth scale

The depth scale indicates distance between bottom of sanding drum and top of conveyor belt. Adjustment is performed by "zeroing" the scale.

1. Unplug sander from power source.
2. With an abrasive strip on drum, lower drum to where it touches top of conveyor belt.
3. At this drum position, the depth scale pointer should align with zero mark on scale. If it does not, loosen two screws (Figure 8-1) and raise or lower scale until zero aligns with the pointer.
4. Retighten screws.

Note: Depending on desired accuracy, you may need to repeat this process when installing different abrasive grits.

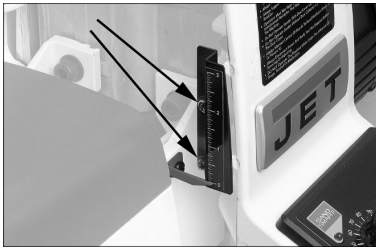

Figure 8-1: depth scale adjustment

8.3 Conveyor belt tension/tracking

Conveyor belt tension adjustment may be necessary during the break-in period to compensate for belt stretching.

8.3.1 Belt tension adjustment

1. Unplug sander from power source.
2. Adjust take-up screw nuts (Figure 8-2) with 5mm hex wrench. Do this on both sides of conveyor to obtain approximately equal tension on both sides of sanding belt when taut.

NOTE: Insufficient belt tension will cause slippage of conveyor belt on drive roller during sanding operation. The conveyor belt is too loose if it can be stopped by hand pressure applied directly to top of moving conveyor belt. Excessive belt tension can result in bent rollers, bent brackets, and/or premature wearing of bushings or conveyor belt.

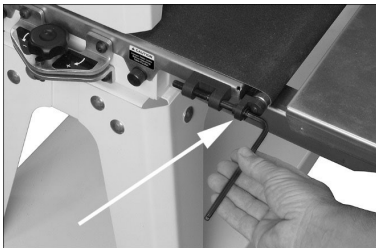

Figure 8-2: belt tension adjustment

8.3.2 Tracking adjustment

A belt tracks correctly when it moves centrally on the conveyor rollers without drifting to either side. Tracking adjustments are made while conveyor belt is running.

1. Unplug sander from power source.

2. Make sure proper belt tension has been achieved (see sect. 8.3.1).
3. Turn on conveyor and set to maximum speed. Watch for tendency of conveyor belt to drift to one side of conveyor. If it drifts, tighten or loosen take-up screw.

Note: Adjust take-up screw only 1/4 turn at a time. Allow time for belt to react to adjustments before proceeding further.

Try to avoid over adjustments, as this may affect belt tension. If tension is affected, it may become necessary to use both take-up screws to accomplish tensioning and tracking.

8.3.3 Trackers

The sander comes equipped with "Trackers", ceramic guides that reduce the amount of adjustments needed to keep conveyor belt tracked (centered) on conveyor table. These guides have a magnetic backing to keep them in place. If a Tracker wears through, it can be reversed by turning it over. See sect. 11.0 Tracker Kit for more information about re-setting trackers.

8.4 Inspecting drum alignment

The sanding drum must be parallel to conveyor table for proper machine operation. The sanding drum comes pre-aligned from the manufacturer. If a problem with drum alignment should occur, follow the instructions below.

First, inspect the alignment with a gauge of some kind. The following procedure uses a steel straight-edge as a gauge.

1. Unplug sander from power source.
2. Open dust cover and remove abrasive strip from drum.
3. Insert gauge between drum and conveyor table at outboard side of drum (A, Figure 8-3).

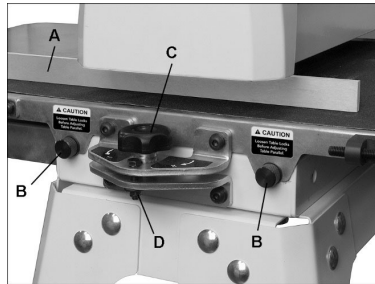

Figure 8-3: drum alignment

4. With dust cover open, lower sanding drum while slowly rotating drum by hand, until drum lightly contacts gauge. **NOTE:** Make sure drum contacts gauge, not just the tension rollers.

5. Remove gauge and place under drum at inboard side.
6. If drum does not contact gauge equally on both ends of drum, alignment is needed.

To align conveyor table with drum:

7. Loosen both table locking screws (B, Figure 8-3)

CAUTION Loosen both table locks before adjusting drum alignment.

8. Turn knob (C) to raise or lower outboard end of table. Follow directional marks on label (+ raises, - lowers).
9. Retighten table lock screws (B).

8.4.1 Fine-tuning drum alignment

Note: This is an operational test for sanding boards wider than the drum. Perform this procedure only after you have become familiar with sander operation.

When sanding boards wider than the drum, table alignment is critical and table must be adjusted exactly level to slightly lower on the outboard end. This will prevent any ridges from developing in the stock. Always check this on a piece of scrap wood, as follows, before sanding the work piece.

1. Run a piece of scrap wood approximately 6" wide by 30" to 40" long through the sander sideways so that end of board extends past outboard side of drum.
2. Without changing drum height, rotate board 180° and sand the same side.
3. If a ridge is visible where the drum overlaps, lower table at outboard end slightly by turning knob (C, Figure 8-3).
4. Repeat this process until the ridge is eliminated and entire board is sanded.

Note: When sanding narrow stock (less than 16"), return conveyor table to parallel position. Turn knob opposite direction until lock nut (D, Figure 8-3) is contacted. The lock nut provides a positive stop for table parallelism.

8.5 Tension roller adjustment

The infeed and outfeed rollers are tensioned to provide downward pressure on the workpiece to prevent slippage on the feed conveyor. Tension rollers have been set by the manufacturer, but should be inspected and may require adjustment as the sander receives use.

WARNING Improperly adjusted tension rollers (i.e. those set too high, rendering them non-functional) could allow kickback of pieces being sanded.

You can increase or decrease tension roller pressure by turning the screws on the tension roller brackets (Figure 8-4).

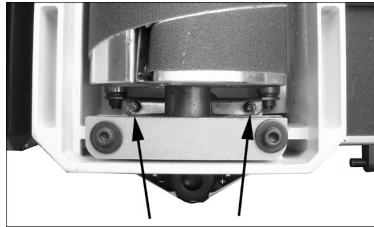

Figure 8-4: tension adjustment screws

Too much tension roller pressure can result in a "snipe" mark, which is a visible line running across the width of the board and located approximately 2-1/4" from end of board.

If snipe occurs on the leading end of board, adjust outfeed tension roller. If the snipe occurs on trailing end of board, adjust infeed tension roller.

9.0 Operations

Before using your drum sander, review the previous sections on initial set-up and adjustment. Before operating, make sure an abrasive strip is mounted and a proper dust collection system is connected.

9.1 Basic Operating Procedure

1. Establish depth of cut.
2. Start dust collection system.
3. Start sanding drum.
4. Start conveyor and select feed rate.
5. Feed stock through machine.

To feed stock through the sander, rest and hold board to be sanded on conveyor belt, allowing conveyor belt to carry board into drum. Once stock is halfway through, reposition yourself to outfeed side of machine to receive and control board as it exits.

CAUTION Board will be forced down against conveyor table as it begins feeding, causing pinching hazard. Keep fingers away.

CAUTION Do not open drum hood until drum comes to a complete stop.

9.2 Switch safety key

To prevent unauthorized use of sander, turn off main switch and pull out safety key (Figure 9-1). Store key in a safe place. Key must be reinserted to start sander.



Figure 9-1: safety key

9.3 Setting depth of cut

Adjusting the drum sander for proper contact between abrasive and stock determines the depth of cut. The depth of cut is controlled by the height adjustment handle.

It may take experimentation to determine proper depth of cut, given the variables of abrasive grit, type of wood, and feed rate. For best results, use scrap wood to practice sanding and to develop skill and familiarity with the machine before doing finish work.

A combination of several variables will determine proper depth of cut to use, including the following:

1. Abrasive type and grit size.
2. Width of piece being processed.
3. Hardness of piece.
4. Feed rate of conveyor belt.

NOTE: The use of a carrier or backer board (not provided), is recommended for cuts 1/16" or less. This is a flat board, usually of wood or MDF, slightly larger than the workpiece and of even thickness, placed beneath the workpiece as it is fed through the sander. The workpiece may be attached to the carrier with rubber cement, carpenter's tape or some other easily removable adhesive. However, some operators use a rubber or textured surface on the carrier to help stabilize the workpiece by simple friction.

9.4 Establishing drum height

A good rule of thumb when sanding with grits finer than 80:

1. To establish drum height, position stock under the drum. Do NOT start drum.
2. Lower drum to the stock thickness, making sure drum can still be rotated by hand while just contacting stock.

⚠WARNING Do not start drum while in contact with stock.

3. Without changing drum height, turn on conveyor and run the stock out from under the drum. Start sanding drum and sand stock at that same position.
4. With the drum operating, feed stock under the drum from the infeed side and against the rotation of the drum. Always maintain control of the stock to avoid kickback and/or slippage.

NOTE: If motor heats up during operation, depth of cut may be too great for size of grit and/or feed rate may be too fast.

For sanding with grits coarser than 80, you can lower the drum slightly.

Always maintain control of stock. Through practice you will learn the proper depth of cut considering the variables above.

9.5 Selecting SandSmart™ feed rates

A faster feed rate allows faster sanding but fewer revolutions of the drum per inch of sanding. A slower feed rate provides more revolutions of the drum per inch of sanding to allow a greater depth of cut and smooth sanding.

Begin experimenting with the feed rate set at about 40% to 50% of maximum. The best feed rate will depend on a number of factors, including type of stock, grit and depth of cut used, and whether the stock is fed directly in line with the conveyor table or at an angle. If the drum motor is lugging down, if conveyor belt is slipping, or if you observe a ripple effect on the stock, slow the feed rate. If the finish is smooth and the machine is not overworking, you can experiment using a faster feed rate.

The SandSmart controller continuously monitors the load on the drum motor, and automatically regulates the speed of the conveyor motor to maintain the highest feed rate without overload.

When the red indicator light (B, Figure 9-2) comes on, the SandSmart control has detected too great a depth of cut and/or too fast a feed rate.



Figure 9-2

If the load on the drum motor increases, the SandSmart control will decrease the conveyor feed rate and will stop the conveyor under extreme conditions. If the load on the drum decreases, SandSmart will increase the feed rate but will not increase it faster than the manual setting on the speed adjustment label.

The best and most consistent finish will be achieved if the conveyor does not change speed during operation.

This change in conveyor speed may affect the finish surface. If the finish is affected, make another sanding pass without changing any settings. If the finish is still affected, make adjustments by slowing the conveyor and/or decreasing the depth of cut and run the stock through again.

Also try a faster feed rate or less depth of cut if the stock you are working begins to show burn marks. With cherry, hard maple or other hardwoods, using a shallower depth of cut and a faster feed rate will help minimize burn marks. Slightly angling the stock as it is fed into the machine will also help prevent burning the stock.

Because of the wide range of variables, it is important to experiment with your specific conditions and make adjustments to achieve the optimum feed rate. If problems occur, first check and adjust the feed rate, referring to the "Troubleshooting" section in this manual.

9.6 Maximum performance tips

The versatility designed into the JWDS-series drum sander allows it to be used for a variety of tasks that will boost return on your investment. For example, it will speed up fine sanding work often done with slower, dust-generating hand sanders, and will achieve fine thickness adjustments not possible on some sanders. It can be used to surface figured woods – bird's eye or curly maple, for example – which can be damaged if fed through a planer.

Learning how to use its adjustments and controls will allow you to fine-tune the machine for maximum results. The best results come from experimenting with different abrasive grits and machine adjustments to fit the job at hand. Following is a list of useful tips which can help you improve performance of your sander.

9.6.1 Dust collection

When connecting dust collectors, remember that straight pipe will not restrict airflow as much as flexible tubing. Y's and elbows will restrict airflow less than T's. Also, a hose smaller than 2-1/2" diameter should not be used.

9.6.2 Multiple-piece sanding runs

When abrasive planing (or thickness sanding) a run of similar pieces that you want to have the same thickness, it is best to determine the thickness of the thinnest piece and process all pieces to that same

thickness in one session. Be aware that the sander will remove cups and crowns in the workpiece; consider this when measuring and processing stock to the same thickness.

9.6.3 Simultaneous multiple pieces

When sanding multiple pieces simultaneously, make sure to stagger (step) the pieces across the width of the conveyor belt. This provides better contact with the tension rollers. Try to process only multiple pieces of similar thickness.

If there is a significant thickness difference, the thinner pieces can slip on the conveyor belt if they do not contact the tension rollers. Also note that pieces thicker than 3/4" should be longer than the minimum normally recommended to prevent tipping of the stock.

9.6.4 Edge sanding

When edge sanding, the sander will mimic the opposite edge of the stock which is lying on the conveyor belt. Because of this, it is important for the stock edge to have been ripped at the proper angle to the face before the sanding process. When edge sanding stock that is less than 3/4" wide or more than 2" high, it is good procedure to stack and clamp several pieces together to prevent them from slipping or tipping on the conveyor belt.

9.6.5 Sanding imperfect stock

When sanding stock with a cup or crown, place the crown up. This will stabilize the stock to help prevent tipping or rocking during sanding. After the crown has been removed and the top is flat, turn the stock over and sand the opposite side. To avoid personal injury, take special care when sanding stock that is twisted, bowed, or otherwise varies in thickness from end to end. If possible, support such stock as it is being sanded to keep it from slipping or tipping. Use extra roller stands, help from another person, or hand pressure on the stock, to minimize potentially hazardous situations.

9.6.6 Face frames and raised panel doors

It is very important to have the proper abrasive contact when doing this type of sanding. If the machine is set to take an excessive depth of cut, the result can be a gouge or dip as the drum goes from sanding the rails at full width to sanding just a few inches of width on the stiles. To prevent this make sure, when using abrasives finer than 80 grit, that the drum is in contact with the wood but can still be spun by hand. If there is room, angling the stock on the conveyor belt can also help.

Slowing the conveyor feed when coming to a rail in the stock can help prevent a dip or gouge. This allows the abrasive to work the wider width with less effort, and to achieve better consistency of the finished surface.

9.6.7 Stock feeding angle

Some pieces, because of their dimensions, will need to be fed into the machine at a 90° angle (perpendicular to drum). However, even a slight offset angle of stock will provide for more effective stock removal. The optimum feeding angle for stock removal is about 60°.

Angling the workpiece for stock removal provides other advantages, such as less loading of certain areas of the drum due to glue lines or mineral streaks in the stock, more even wear of abrasive strips, potentially faster feed rates, and lighter loads on the motor. Note that to get the best final finish, however, the stock should be fed through the machine so it will be sanded in line with the grain of the wood on the final one or two passes.

10.0 User-maintenance

⚠WARNING Before doing maintenance on the machine, disconnect it from the electrical supply (pull out the plug), unless indicated otherwise. Failure to comply may cause serious injury.

10.1 Cleaning and lubrication

For best results, make cleaning the sander a regular shop procedure. Allowing excess build-up of dust and debris can adversely affect performance through loading of the abrasives, slippage on the conveyor table, and/or the accumulation of material inside the drums which can throw off the center of balance.

Leave the dust collector on when cleaning dust from the drums. Also brush the conveyor belt after cleaning operations. If not cleaned, the conveyor belt could allow stock to slip during sanding operations.

NOTE: Bearings are pre-sealed and require no lubrication.

- Lubricate conveyor bushings as needed, and check for wear.
- Lubricate elevating leadscrew (A, Figure 10-1) as needed.
- Clean sawdust from abrasive strip and brush dust from conveyor belt.
- Keep slide areas clean (B, Figure 10-1).
- Blow dust from motors and switches. Blow dust from inside of sanding drum, which may cause vibration or offset the center of balance.
- Check all set screws for tightness on parts such as bearings, conveyor table, and couplings.

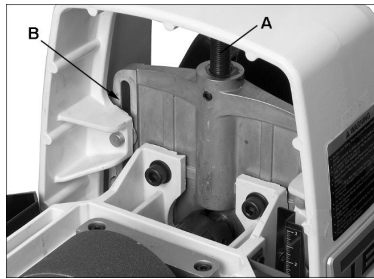

Figure 10-1

10.2 Drum maintenance

The drum should not require removal from the machine under normal circumstances. Should maintenance ever become necessary, the drum has been designed for easy removal and replacement.

Remove four socket head screws (C, Figure 10-2). Carefully lift out drum with coupling (D) attached.

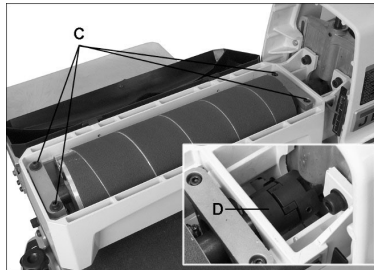

Figure 10-2: drum removal

10.3 Conveyor belt replacement

1. Disconnect sander from power.
2. Raise drum to highest position.
3. Turn take-up screws (Figure 8-2) on both sides of conveyor to relieve belt tension, and slide the driven roller fully inward.
4. Remove two (2) screws that attach conveyor table to base.
5. Remove two (2) screws that attach conveyor table to drum alignment bracket (E, Figure 10-3).
6. Loosen two locks (F, Figure 10-3).
7. Lift up conveyor table and remove it from machine. Avoid tearing the belt on any edges underneath the conveyor table. Do not allow the Trackers to drop, as they may break.

8. Set conveyor on motor side and slide conveyor belt off end of conveyor table.
9. Install new belt along with trackers (see sect. 11.0), and re-install conveyor table. Tension and track the new belt.

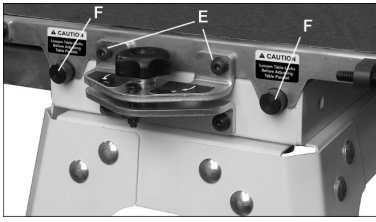

Figure 10-3

Note: If conveyor belt continually tracks to one side of the machine, reversing the belt on the conveyor table may remedy the problem. To make sure the conveyor table is not twisted, place a level on the conveyor table. Level the machine if needed. If there is still a problem, proceed with the steps below:

Step 1: Check conveyor drive roller and driven roller to make sure they are parallel to surface of conveyor table. To do this, first center conveyor belt on the conveyor table. Then lay a straight-edge on the exposed edge of conveyor table on left (outboard) side, extending it over the roller. Note distance between roller and straightedge.

Step 2: Now repeat Step 1 on right (inboard) side of conveyor. Compare the measurements from side to side. If they are not equal, loosen one of the brackets that hold the roller in place. Tip this bracket until distance between roller and straight-edge are equal from side to side, then tighten bracket.

10.4 Commutator brush inspection

To maintain motor efficiency, inspect the two carbon brushes every two months, or more frequently if sander is heavily used. Stalling or loss of power may be a symptom of worn carbon brushes. If one brush is worn out, replace both at the same time.

CAUTION Continued use of damaged or worn brushes may result in damage to motor armature.

1. Unplug sander from power source.
2. Unscrew and remove cap with flat blade screwdriver. See Figure 10-4.
3. Gently pry up an edge of the brass clip, until the spring causes it to disengage from hole. (Notice orientation of brush as you remove it; it should be inserted in the same manner; curvature of brush will match curvature of motor.)

4. Pull out brush and inspect. Brush should be replaced if any of the following are discovered:
 - Brush has worn to about 1/2-inch long.
 - Signs of crumbling, burning or breaking.
 - End of brush is rough or pitted.
 - Abnormal coloration of spring
 - Broken lead in spring
 - Collapsed spring
5. Install new brush (or reinstall current brush) and gently press it all the way into hole until the brass clip is secured.
6. Install cap.
7. Repeat for other brush.

NOTE: It is recommended that sander be run without load for several minutes to seat new brushes.

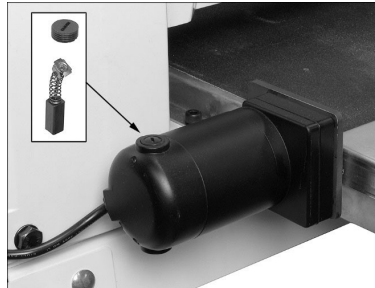

Figure 10-4

10.5 Additional servicing

Any additional servicing should be performed by an authorized service technician.

11.0 Tracker kit

Stock No.: PM2244-213

Trackers dramatically reduce tracking adjustments of conveyor belts. They are already installed on your sander. The following information is for resetting or replacing your trackers, should that become necessary.

1. Disconnect power to sander.
2. Raise drum as high as it will go.
3. Turn both conveyor take-up screws to relieve conveyor belt tension and slide driven roller fully inward.
4. Remove the four bolts holding conveyor table to sander base.
5. Lift conveyor table and slide it out of sander. Turn conveyor table upside down. Be careful not to damage conveyor belt.
6. On the underside of the conveyor table, there are U-channels welded to the table. The Tracker is positioned on the inside of the first U-channel on the infeed side of sander (Figure 11-1). The back of tracker is magnetized and will stick to side wall of conveyor table. Do not install tracker if edge of conveyor belt is damaged or torn.
7. With first tracker installed, slide conveyor belt into bottom slot of tracker. **Note:** When installed properly, only bottom lip of tracker will be visible. The top slot can be used if bottom slot wears out.
8. Install second tracker opposite the first. Use both trackers unless the second one does not fit in conveyor or unless conveyor belt is damaged.
9. Turn conveyor table right-side up and reposition it onto sander. Re-attach three mounting screws and tighten. **Caution:** Be careful not to knock tracker(s) out of conveyor table when turning conveyor over. Trackers may break if allowed to fall.
10. Make sure all switches are off. Connect power to sander and plug in motor.
11. Tension conveyor belt using take-up screws. If both trackers are installed, it is very important to have equal tension on both sides of conveyor belt. Turn take-up screws on both sides until equal tension is obtained.
12. To check tension, turn on conveyor full speed and place both hands on conveyor. If conveyor belt can be stopped, continue tensioning until conveyor belt cannot be stopped by both hands on the belt while conveyor is operating at full speed.
13. Make sure conveyor belt runs smoothly inside tracker slot and that the magnet is holding the tracker in position.
14. Continue to watch tracking of conveyor and adjust only if necessary, making sure to keep equal tension on conveyor belt at all times and not allowing conveyor belt to buckle under conveyor table.

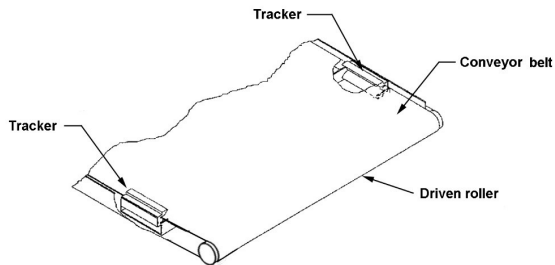

Figure 11-1: Underside of conveyor shown

12.0 Abrasives

The abrasive material you choose will have a substantial effect on the performance of your sander. Variations in paper type, weight, coating and durability all contribute to achieving your desired finish.

JET Abrasives are available in Ready-To-Wrap™ pre-cut lengths or in the convenient Ready-To-Cut pre-marked box. Your JET dealer can recommend the best choice for your application.

12.1 Selecting drum abrasives

It is important to select the proper grit of abrasive for the type of sanding being performed to achieve maximum results. As with any sanding operation, first begin sanding with a coarser grit, depending upon the roughness of the stock or the amount of stock to be removed. Then progressively work toward finer grits. The chart below shows the general uses for the various grits.

The amount of stock to be removed is a major consideration when choosing the grit grade with which to begin. Grits 24, 36, 50 and 60 are primarily designed for stock removal. Grits 24 and 36 will remove the most material in one pass, whether you are doing abrasive planing, cleaning up glued panels, or flattening stock. Grits from 100 through 220 are primarily finishing grits designed to remove the scratch pattern from the previous grit used. For best results, never skip more than one grit grade when progressing through a sanding sequence.

For fine work, such as furniture, try not to skip any grit grades during the sanding process.

In general, premium quality abrasives will produce a better finish with a less noticeable scratch pattern.

Note: Grits that are too fine can sometimes burnish the wood and leave a glossy surface which will not accept stains evenly. This will vary by type of wood. Oak, for example, is susceptible to burnishing because of its open pores.

12.2 Cleaning abrasive strips

Regularly clean the abrasive strip on the drum with commercially available cleaning sticks, following the manufacturer's directions. When cleaning, also brush the stick crumbs from the drum while it is still rotating.

In some cases, heavy loaded areas can be removed with Plexiglas held on edge over the rotating drum.

CAUTION Always wear eye protection while performing sandpaper cleaning, and take all precautions to avoid any contact of hands or clothing with the rotating drum.

Cloth-backed abrasives can be cleaned by soaking in paint thinner or mineral spirits for 20 minutes to one hour, then using a brush to remove any build-up. Dry the abrasive strips completely before using. Any used solvents should be discarded in compliance with environmental regulations.

12.3 Increasing abrasive life

Abrasive life can be increased not only by cleaning, but by removing the abrasive strip from the drum and reversing it. To do this, remove the strip and use what was the trailing end as the starting end on the left (outboard) side of the drum. Reversing the strip will provide a fresh set of cutting edges on the abrasive.

12.4 Abrasive selection guide

Grit	Common Application
24	Abrasive planing, surfacing rough-sawn boards, maximum stock removal, glue removal.
36	Abrasive planing, surfacing rough-sawn boards, maximum stock removal, glue removal.
50	Surfacing and dimensioning boards, truing warped boards
60	Surfacing and dimensioning boards, truing warped boards.
80	Light dimensioning, removal of planer ripples.
100	Light surfacing.
120	Light surfacing, minimal stock removal.
150	Finish sanding, minimal stock removal.
180	Finish sanding only, not for stock removal.
220	Finish sanding only, not for stock removal.

Table 2

13.0 Troubleshooting JWDS-series Drum Sander

Symptom	Possible Cause	Correction *
Drum motor won't start when switch is activated.	No incoming current.	Check connections at plug or circuit panel.
	Safety key missing from switch.	Install safety key.
	Low voltage.	Check power line for proper voltage.
	Open circuit in motor or loose connection.	Inspect all lead connections on motor for loose or open connections.
	Switch malfunction.	Replace switch.
Drum motor will not start: fuses blow or circuit breakers trip.	Short circuit in line cord or plug.	Inspect cord or plug for damaged insulation and shorted wires.
	Short circuit in motor or loose connections.	Inspect all connections on motor for loose or shorted terminals or worn insulation.
	Incorrect fuse or circuit breaker in power line.	Install correct fuse or circuit breaker.
Drum motor overheats.	Air circulation through motor restricted.	Clean motor fan with compressed air to restore normal air circulation.
	Motor overloaded (SandSmart not functioning properly).	Have controls inspected and repaired.
Drum motor stalls, resulting in blown fuses or tripped circuit.	Short circuit in motor or loose connections.	Inspect connections on motor for loose or shorted terminals or worn insulation.
	Low voltage.	Correct low voltage conditions.
	Incorrect fuse or circuit breaker in power line.	Install correct fuse or circuit breaker.
Loud, repetitive noise or vibration coming from machine.	Fasteners loose.	Inspect fasteners and tighten where needed.
	Motor fan is hitting cover.	Tighten fan or shim fan cover.
	Machine not level.	Place sander on level floor; shim if needed.
Conveyor motor stalls.	Excessive depth of cut.	Reduce depth of cut; use coarser grit; reduce feed rate.
Conveyor belt does not move.	Shaft coupler is loose or unattached.	Adjust shaft coupler.
Conveyor rollers run intermittently.	Shaft coupling is loose.	Align the shaft flats of the gear motor and the drive roller and tighten the shaft-coupling setscrews.
Conveyor belt slips on drive roller.	Improper conveyor belt tension.	Adjust belt tension.
	Excessive depth of cut and/or feed rate.	Reduce depth of cut and/or feed rate.
Abrasive strip comes off drum.	Slack in abrasive strip on drum.	Remove slack in strip.
	Abrasive improperly wrapped.	Read the section on installing abrasives, and rewrap.
Abrasive strip is loose.	Strip caught on inside edge of slot, or on inboard side of drum.	Re-adjust the strip end in the slot and/or trim the abrasive edge.
	Strip not cut properly.	Re-cut and re-install the abrasive strip.
Abrasive loads up prematurely.	Excessive depth of cut.	Reduce depth of cut.
	Excessive feed rate.	Reduce feed rate.
	Inadequate dust collection.	Increase airflow at dust port.
	Inadequate abrasive.	Use an open-coat abrasive.
Line or groove in stock.	Inconsistent feed rate.	Do not stop or change the feed rate while feeding stock.
Snipe marks.	Improper tension on rollers.	Re-tension rollers.

Symptom	Possible Cause	Correction *
Sander burns wood.	Abrasive strip is overlapped.	Re-wrap abrasive strip.
	Abrasive is loaded.	Clean abrasive.
	Depth of cut excessive for fine grit.	Use coarser grit or reduce depth of cut.
	Feed rate too slow.	Increase feed rate.
Board slips on conveyor belt.	Abrasive is worn.	Replace abrasive.
	Tension rollers too high.	Lower tension rollers.
	Excessive feed rate.	Reduce feed rate.
Ripples in sanded surface. A. Non-uniformly spaced ripples. B. Uniformly spaced ripples.	Dirty or worn conveyor belt.	Replace conveyor belt.
	A. Uneven feed rate.	Conveyor belt slipping (see above) Board slips on conveyor belt (see above). Conveyor motor stalls (see above).
Wood is gouged.	B. Conveyor table flexing or vibration.	Reduce depth of cut and/or feed rate. Check for loose bolts, loose shaft coupling set screws, or out-of-balance drum.
	Stock slipping on conveyor.	Correct depth of cut or roller tension.
	Work piece not properly supported.	Add work supports for long work pieces.

* **WARNING:** Some corrections may require a qualified electrician.

Table 3

14.0 Optional accessories

98-0130	Locking Casters, set of 4
723521	Infeed/Outfeed Tables

The following abrasives are available *only for model JWDS-1632*
(Abrasive strips are 3" wide, cloth backed, aluminum oxide, resin bond, open coat.)

60-6036	Ready-To-Wrap™ Abrasive Strip, 36 Grit, (4 wraps in a box)
60-6060	Ready-To-Wrap™ Abrasive Strip, 60 Grit, (4 wraps in a box)
60-6080	Ready-To-Wrap™ Abrasive Strip, 80 Grit, (4 wraps in a box)
60-6100	Ready-To-Wrap™ Abrasive Strip, 100 Grit, (4 wraps in a box)
60-6120	Ready-To-Wrap™ Abrasive Strip, 120 Grit, (4 wraps in a box)
60-6150	Ready-To-Wrap™ Abrasive Strip, 150 Grit, (4 wraps in a box)
60-6180	Ready-To-Wrap™ Abrasive Strip, 180 Grit, (4 wraps in a box)
60-6220	Ready-To-Wrap™ Abrasive Strip, 220 Grit, (4 wraps in a box)
60-9036	Premium Ready-To-Cut™ Abrasive Strip, 36 Grit
60-9060	Premium Ready-To-Cut™ Abrasive Strip, 60 Grit
60-9080	Premium Ready-To-Cut™ Abrasive Strip, 80 Grit
60-9100	Premium Ready-To-Cut™ Abrasive Strip, 100 Grit
60-9120	Premium Ready-To-Cut™ Abrasive Strip, 120 Grit
60-9150	Premium Ready-To-Cut™ Abrasive Strip, 150 Grit
60-9180	Premium Ready-To-Cut™ Abrasive Strip, 180 Grit
60-9220	Premium Ready-To-Cut™ Abrasive Strip, 220 Grit

The following abrasives are available *only for model JWDS-1836*
(Abrasive strips are 3-3/8" wide, cloth backed, aluminum oxide, resin bond, open coat.)

60-18036	Ready-To-Wrap™ Abrasive Strip, 36 Grit, (4 wraps in a box)
60-18060	Ready-To-Wrap™ Abrasive Strip, 60 Grit, (4 wraps in a box)
60-18080	Ready-To-Wrap™ Abrasive Strip, 80 Grit, (4 wraps in a box)
60-18100	Ready-To-Wrap™ Abrasive Strip, 100 Grit, (4 wraps in a box)
60-18120	Ready-To-Wrap™ Abrasive Strip, 120 Grit, (4 wraps in a box)
60-18150	Ready-To-Wrap™ Abrasive Strip, 150 Grit, (4 wraps in a box)
60-18180	Ready-To-Wrap™ Abrasive Strip, 180 Grit, (4 wraps in a box)
60-18220	Ready-To-Wrap™ Abrasive Strip, 220 Grit, (4 wraps in a box)

15.0 Replacement Parts

Replacement parts are listed on the following pages. To order parts or reach our service department, call 1-800-274-6848 Monday through Friday, 8:00 a.m. to 5:00 p.m. CST. Having the Model Number and Serial Number of your machine available when you call will allow us to serve you quickly and accurately.

Non-proprietary parts, such as fasteners, can be found at local hardware stores, or may be ordered from JET.

Some parts are shown for reference only, and may not be available individually.

15.1.1 JWDS-1632/-1836 Head Assembly – Exploded View

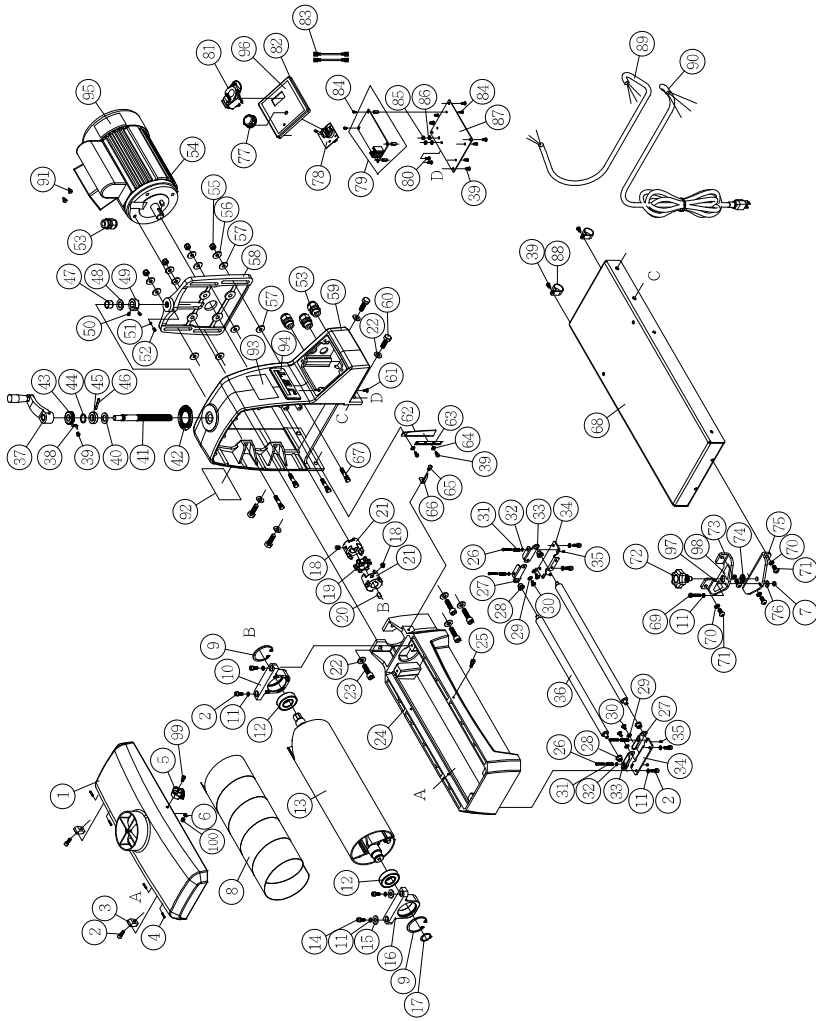

15.1.2 JWDS-1632/-1836 Head Assembly – Parts List

Index No	Part No	Description	Size	Qty
1	JWDS1632-101	Dust Hood		1
	JWDS1836-101	Dust Hood		1
2	TS-1503041	Socket Head Cap Screw	M6 x 1.0P x 16L	8
3	JWDS1632-103	Drum Carriage Hinge		2
4	40317-15	Spring Pin	3 x 14L	4
5	PM2244-109	Knob		1
6	TS-1550031	Flat Washer	5 x 12 x 1T mm	1
7	F001753	Nyloc Nut BO	M6 x 1.0P	1
8		Abrasive (see sect. 14.0 for replacements)		1
9		Retainer Ring (Re:13A)	RTW-52	2
10		Inboard Bearing Housing (Re:13A)		1
11	TS-2361061	Lock Washer	M6	9
12		Ball Bearing (Re:13A)	6205VV	2
13		Drum (Re:13A)		1
13A	JWDS1632-113A	Drum Assembly (includes #2, 9-21)		1
	JWDS1836-113A	Drum Assembly (includes #2, 9-21)		1
14	F005384	Socket Head Cap Screw	M6 x 1.0P x 25L	2
15	JWDS1632-115	Flat Washer	6.5 x 19 x 3t	2
16		Outboard Bearing Housing (Re:13A)		1
17		Retainer Ring (Re:13A)	STW-25	1
18	F010408	Socket Set Screw	M8 x 1.25P x 10L	2
19		Rubber Cushion (Re:13A)		1
20		Key (Re:13A)	8 x 7 x 20L	2
21		Coupling (Re:13A)		2
22	F002643	Flat Washer	10 x 20 x 2.0T	8
23	F005430	Socket Head Cap Screw	M10 x 1.5P x 35L	4
24	JWDS1632-124	Drum Carriage		1
	JWDS1836-124	Drum Carriage		1
25	TS-1502021	Socket Head Cap Screw	M5 x 0.5P x 10L	1
26	JWDS1632-126	Phillips Round Head Screw	M4 x 0.7P x 25L	4
27	PM2244-129	Left Tension Roller Suspension Bracket		2
28	PM2244-130	Oilite Bushing		4
30	PM2244-132	Shoulder Screw		4
29	TS-1550041	Flat Washer	6.5 x 13 x 1T	4
31	PM2244-125	Compression Spring		4
32	TS-1550021	Flat Washer	4.2 x 8 x 0.8T	4
33	PM2244-131	Right Tension Roller Suspension Bracket		2
34	PM2244-128	Tension Roller Bracket		2
35	JWDS1632-135	Socket Head Set Screw w/LocTite	M4 x 0.7P x 5L	4
36	JWDS1632-136	Tension Roller		2
	JWDS1836-136	Tension Roller		2
37	JWDS1632-137	Crank Handle		1
38	JWDS1632-138	Pointer		1
39	JWDS1632-139	Phillips Round Head Screw	M5 x 0.8P x 8L	9
40	JWDS1632-140	Oilite Washer		1
41	JWDS1632-141	Height Adjusting Screw		1
42	JWDS1632-142	Incremental Depth Scale		1
43	JWDS1632-143	Dial		1
44	JWDS1632-144	O-Ring	P11	1
45	JWDS1632-145	Collar		1
46	JWDS1632-146	Spring Pin	4 x 30L	1
47	JWDS1632-147	Oilite Bushing		1
48	JWDS1632-148	Nylon Washer		1
49	JWDS1632-149	Collar		1
50	TS-1523031	Socket Head Set Screw	M6 x 1.0P x 10L	2
51	PM2244-184	PU Block		1
52	5302731	Socket Head Set Screw	M8 x 1.25P x 6L	1
53	JWDS1632-153	Strain Relief	PG 13.5	4

NOTE: JWDS-1632 and JWDS-1836 have different parts on Index #1, 13A, 24, 36, 54.

Index No	Part No	Description	Size	Qty
54	JWDS1632-154	Motor	1.5HP, 115V, 60Hz	1
	JWDS1632-154SC	Starting Capacitor (not shown)	300MFD 125VAC	1
	JWDS1632-154SCC	Starting Capacitor Cover (not shown)		1
	JWDS1632-154FC	Fan Cover (not shown)		1
	JWDS1632-154CF	Cooling Fan (not shown)		1
	JWDS1836-154	Motor	1.75HP, 115V, 60Hz	1
	JWDS1632-154SC	Starting Capacitor (not shown)	300MFD 125VAC	1
	JWDS1632-154SCC	Starting Capacitor Cover (not shown)		1
	JWDS1836-154RC	Running Capacitor (not shown)	50µF 250VAC	1
	JWDS1632-154FC	Fan Cover (not shown)		1
	JWDS1632-154CF	Cooling Fan (not shown)		1
55	TS-1541031	Nyloc Nut	M8 x 1.25P	4
56	TS-1550061	Flat Washer	8.2 x 23 x 2T	4
57	JWDS1632-157	Oilite Washer		8
58	JWDS1632-158	Motor Plate		1
59	JWDS1632-159	Motor Shroud		1
60	TS-1491041	Hex Cap Screw	M10 x 1.5P x 30L	4
61	JWDS1632-161	Self Tapping Screw	M4 x 15L	4
62	JWDS1632-162	Depth Scale Bracket (includes #63)		1
63	JWDS1632-163	Depth Scale		1
64	TS-1550031	Flat Washer	5.1 x 12 x 1T	2
65	TS-1534032	Phillips Pan Hd Machine Screw	M6 x 1.0P x 10L	1
66	JWDS1632-166	Pointer		1
67	JWDS1632-167	Stud		4
68	JWDS1632-168	Base		1
69	TS-1482061	Hex Cap Screw	M6 x 1.0P x 30L	1
70	TS-2361081	Lock Washer	M8	4
71	TS-2248162	Socket Head Button Screw	M8 x 1.25 x 16L	4
72	JWDS1632-172	Knob		1
73	JWDS1632-173	Parallel Adjust Moving Bracket		1
74	JWDS1632-174	Oilite Washer		1
75	JWDS1632-175	Parallel Adjust Fixed Bracket		1
76	TS-1550041	Flat Washer	6.5 x 19 x 2T	1
77	PM2244-196	Knob		1
78	JWDS1632-178	Potentiometer		1
79	JWDS1632-179	Circuit Board		1
80	TS-1533042	Phillips Pan Hd Machine Screw	M5 x 0.8P x 12L	2
81	JSG96-135	Switch		1
	JSG96-135A	Switch Key (not shown)		1
82	JWDS1632-182	Control Panel		1
83	JWDS1632-183	Internal Connection Cable		1
84	TS-1531012	Phillips Pan Hd Machine Screw	M3 x 0.5P x 5L	8
85	TS-1540031	Hex Nut	M5 x 0.8P	2
86	F002097	Lock Washer, Ext. Tooth	M5	2
87	JWDS1632-187	Circuit Board Holder		1
88	JWDS1632-188	Cable Management	ACC-8-B	2
89	JWDS1632-189	Motor Cable		1
90	JWDS1632-190	Power Cable		1
91	JWDS1632-191	Wiring Nut	SW-P4H	2
92	LM000237	ID Label, JWDS-1632		1
93	LM000238	Warning Label		1
94	JWDS1632-194	JET Logo	113x47mm	1
95	JWDS1632-195	Motor Label		1
96	JWDS1632-196	Control Panel Label		1
97	JWDS1632-197	Left Parallel Adjust Label		1
98	JWDS1632-198	Right Parallel Adjust Label		1
99	JWDS2244-106	Socket Head Cap Screw	M5-0.8P x 18L	1
100	TS-1541011	Nylon Lock Hex Nut	M5-0.8	1

15.2.1 JWDS-1632/-1836 Conveyor Table Assembly – Exploded View

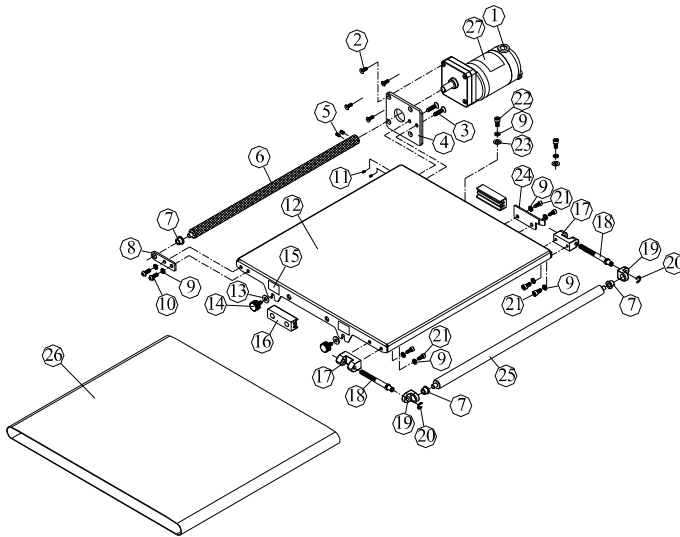

15.2.2 JWDS-1632/-1836 Conveyor Table Assembly – Parts List

Index No	Part No	Description	Size	Qty
1	JWDS1632-201	Belt Motor		1
	JWDS1632-201-1	Carbon Brush (not shown)		2
2	F010839	Socket Head Flat Screw	#10-32 x 1/2"L	4
3	F010985	Socket Head Flat Screw	M6 x 1.0P x 35L	2
4	JWDS1632-204	Belt Motor Plate		1
5	TS-1522011	Socket Head Set Screw	M5 x 0.8P x 5L	2
6	JWDS1632-206	Drive Roller		1
7	PM2244-130	Oilite Bushing		3
8	JWDS1632-208	Drive Roller Bracket		1
9	TS-2361061	Lock Washer	M6	8
10	TS-2246162	Socket Head Button Screw	M6 x 1.0P x 16L	2
11	TS-1521021	Socket Head Set Screw	M4 x 0.7P x 5L	2
12	JWDS1632-212	Conveyor Table		1
13	TS-1550041	Flat Washer	6.4 x 19 x 1.5T	2
14	JWDS1632-214	Table Lock Knob		2
15	LM000236	Caution Label – Table Lock		2
16	PM2244-213	Tracker Kit (set of 2)		2
17	JWDS1632-217	Bracket		2
18	JWDS1632-218	Adjusting Rod		2
19	JWDS1632-219	Driven Roller Bracket		2
20	JWDS1632-220	Retaining Ring	ETW-7	2
21	TS-1503031	Socket Head Cap Screw	M6 x 1.0P x 12L	6
22	TS-1503041	Socket Head Cap Screw	M6 x 1.0P x 16L	2
23	TS-0680021	Flat Washer	1/4" x 16 x 2T	2
24	JWDS1632-224	Guide Plate		1
25	JWDS1632-225	Driven Roller		1
26	JWDS1632-226	Conveyor Belt		1
27	JWDS1632-227	Belt Motor Label		1

15.3.1 JWDS-1632/-1836 Infeed and Outfeed Tables (OPTIONAL) – Exploded View

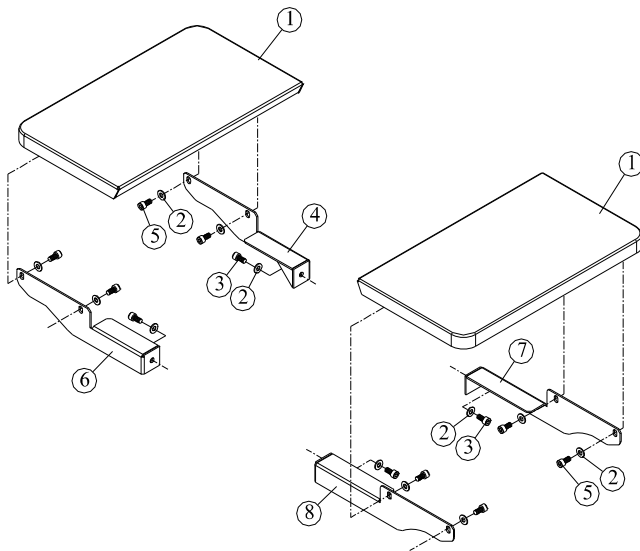

15.3.2 JWDS-1632/-1836 Infeed and Outfeed Tables (OPTIONAL) – Parts List

Index No	Part No	Description	Size	Qty
.....	723521	Infeed/Outfeed Tables (includes #1-8)
1	JWDS1632-401	Extension Table	2
2	TS-1550061	Flat Washer	8.3 x 18 x 1.5T	12
3	TS-1504031	Socket Head Cap Screw	M8 x 1.25P x 16L	4
4	JWDS1632-404	Rear-Right Table Bracket	1
5	TS-1504021	Socket Head Cap Screw	M8 x 1.25P x 12L	8
6	JWDS1632-405	Rear-Left Table Bracket	1
7	JWDS1632-406	Front-Right Table Bracket	1
8	JWDS1632-407	Front-Left Table Bracket	1

15.4.1 JWDS-1632/-1836 Open Stand Assembly – Exploded View

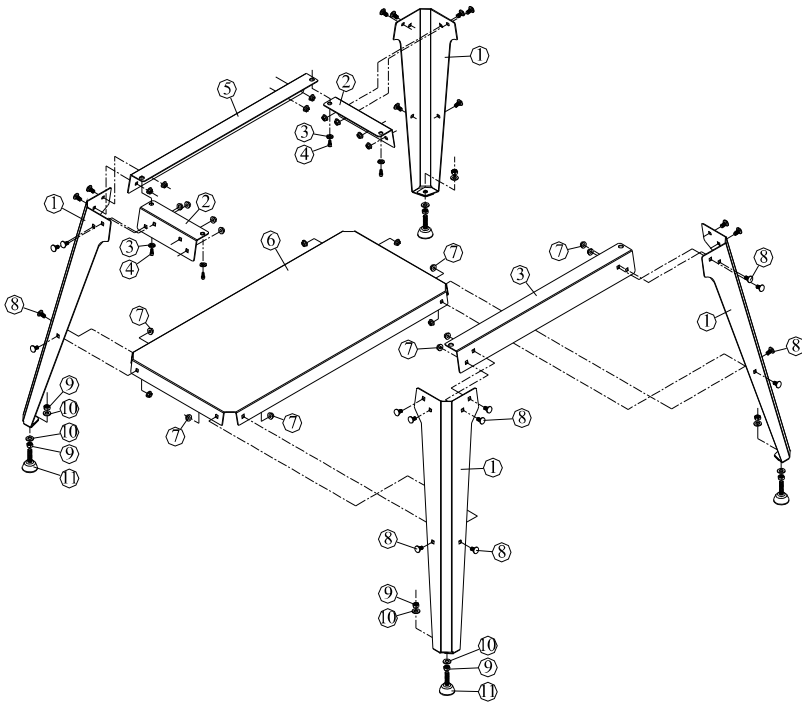

15.4.2 JWDS-1632/-1836 Open Stand Assembly – Parts List

Index No	Part No	Description	Size	Qty
.....	723520S.....	Open Stand Assembly (includes #1-11).....		1
1.....	JWDS1632-301.....	Leg.....		4
2.....	JWDS1632-302.....	Short Rail.....		2
3.....	TS-1550061.....	Flat Washer.....	8.3 x 18 x 1.5T.....	4
4.....	TS-1504031.....	Socket Head Cap Screw.....	M8 x 1.25P x 16L.....	4
5.....	JWDS1632-305.....	Long Rail.....		2
6.....	JWDS1632-306.....	Shelf.....		1
7.....	JWDS1632-307.....	Flange Lock Nut.....	M8 x 1.25P.....	24
8.....	JWDS1632-308.....	Carriage Bolt.....	M8 x 1.25P x 16L.....	24
9.....	TS-1540071.....	Hex Nut.....	M10 x 1.5P.....	8
10.....	TS-1550071.....	Flat Washer.....	10 x 20 x 2.0T.....	8
11.....	JWDS1632-311.....	Leveling Foot.....		4

16.0 Electrical Connections for JWDS-1632/-1836

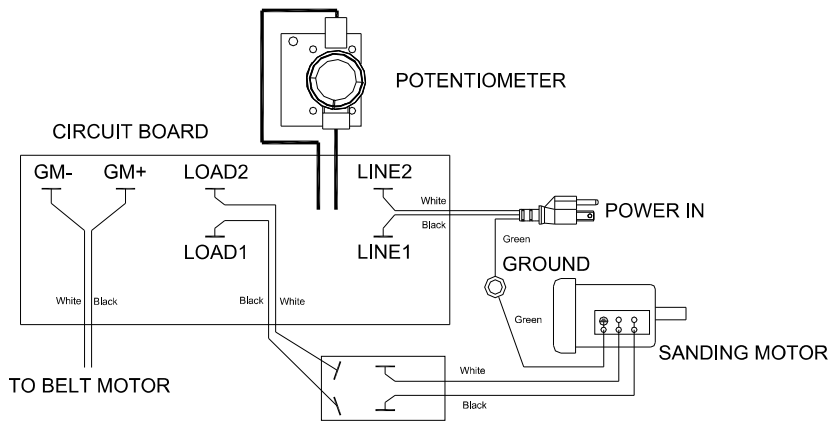

17.0 Warranty and service

JET warrants every product it sells against manufacturers' defects. If one of our tools needs service or repair, please contact Technical Service by calling 1-800-274-6846, 8AM to 5PM CST, Monday through Friday.

Warranty Period

The general warranty lasts for the time period specified in the literature included with your product or on the official JET branded website.

- JET products carry a limited warranty which varies in duration based upon the product. (See chart below)
- Accessories carry a limited warranty of one year from the date of receipt.
- Consumable items are defined as expendable parts or accessories expected to become inoperable within a reasonable amount of use and are covered by a 90 day limited warranty against manufacturer's defects.

Who is Covered

This warranty covers only the initial purchaser of the product from the date of delivery.

What is Covered

This warranty covers any defects in workmanship or materials subject to the limitations stated below. This warranty does not cover failures due directly or indirectly to misuse, abuse, negligence or accidents, normal wear-and-tear, improper repair, alterations or lack of maintenance. JET woodworking machinery is designed to be used with Wood. Use of these machines in the processing of metal, plastics, or other materials outside recommended guidelines may void the warranty. The exceptions are acrylics and other natural items that are made specifically for wood turning.

Warranty Limitations

Woodworking products with a Five Year Warranty that are used for commercial or industrial purposes default to a Two Year Warranty. Please contact Technical Service at 1-800-274-6846 for further clarification.

How to Get Technical Support

Please contact Technical Service by calling 1-800-274-6846. **Please note that you will be asked to provide proof of initial purchase when calling.** If a product requires further inspection, the Technical Service representative will explain and assist with any additional action needed. JET has Authorized Service Centers located throughout the United States. For the name of an Authorized Service Center in your area call 1-800-274-6846 or use the Service Center Locator on the JET website.

More Information

JET is constantly adding new products. For complete, up-to-date product information, check with your local distributor or visit the JET website.

How State Law Applies

This warranty gives you specific legal rights, subject to applicable state law.

Limitations on This Warranty

JET LIMITS ALL IMPLIED WARRANTIES TO THE PERIOD OF THE LIMITED WARRANTY FOR EACH PRODUCT. EXCEPT AS STATED HEREIN, ANY IMPLIED WARRANTIES OF MERCHANTABILITY AND FITNESS FOR A PARTICULAR PURPOSE ARE EXCLUDED. SOME STATES DO NOT ALLOW LIMITATIONS ON HOW LONG AN IMPLIED WARRANTY LASTS, SO THE ABOVE LIMITATION MAY NOT APPLY TO YOU.

JET SHALL IN NO EVENT BE LIABLE FOR DEATH, INJURIES TO PERSONS OR PROPERTY, OR FOR INCIDENTAL, CONTINGENT, SPECIAL, OR CONSEQUENTIAL DAMAGES ARISING FROM THE USE OF OUR PRODUCTS. SOME STATES DO NOT ALLOW THE EXCLUSION OR LIMITATION OF INCIDENTAL OR CONSEQUENTIAL DAMAGES, SO THE ABOVE LIMITATION OR EXCLUSION MAY NOT APPLY TO YOU.

JET sells through distributors only. The specifications listed in JET printed materials and on official JET website are given as general information and are not binding. JET reserves the right to effect at any time, without prior notice, those alterations to parts, fittings, and accessory equipment which they may deem necessary for any reason whatsoever. JET® branded products are not sold in Canada by JPW Industries, Inc.

Product Listing with Warranty Period

90 Days – Parts; Consumable items
1 Year – Motors; Machine Accessories
2 Year – Metalworking Machinery; Electric Hoists; Electric Hoist Accessories; Woodworking Machinery used for industrial or commercial purposes
5 Year – Woodworking Machinery
Limited Lifetime – JET Parallel clamps; VOLT Series Electric Hoists; Manual Hoists; Manual Hoist Accessories; Shop Tools; Warehouse & Dock products; Hand Tools; Air Tools

NOTE: JET is a division of JPW Industries, Inc. References in this document to JET also apply to JPW Industries, Inc., or any of its successors in interest to the JET brand.

This page intentionally left blank.



427 New Sanford Road
LaVergne, Tennessee 37086
Phone: 800-274-6648
www.jettools.com