

OPERATING, MAINTENANCE & PARTS MANUAL

ELECTRIC CHAIN

COFFING® HOISTS JLC SERIES

Before installing hoist, fill in the information below.

Model Number. _____

Serial No. _____

Purchase Date _____

Please provide Serial Number when ordering parts.

MODEL NUMBERS:

**JLC0232, JLC0516, JLC0532, JLC1016,
JLC1032, JLC2016, JLC4008**

For JLCET models refer to this manual
and ETB680-1 for trolley information.

**Follow all instructions and warnings for inspecting,
maintaining and operating this hoist.**

The use of any hoist presents some risk of personal injury or property damage. That risk is greatly increased if proper instructions and warnings are not followed. Before using this hoist, each operator should become thoroughly familiar with all warnings, instructions and recommendations in this manual. **Retain this manual for future reference and use.**

Forward this manual to hoist operator. Failure to operate equipment as directed in the manual may cause injury.

Should you have any questions regarding this product, please call Coffing Hoists at **(800) 477-5003**.

Assembled in USA with Imported and Domestic Components



COFFING HOIST PARTS AND SERVICES ARE AVAILABLE IN THE UNITED STATES AND IN CANADA

As a COFFING Hoist and Trolley user you are assured of reliable repair and parts services through a network of Master Parts Depots and Service Centers that are strategically located in the United States and Canada. These facilities have been selected on the basis of their demonstrated ability to handle all parts and repair requirements promptly and efficiently. To quickly obtain the name of the Master Parts Depot or Service Center located nearest you, call (800) 888-0985, Fax: (716) 689-5644, visit www.cmworks.com.

LAS PIEZAS Y REPARACIONES DE LOS POLIPASTOS DE COFFING ESTÁN ASEGURADAS EN ESTADOS UNIDOS Y CANADÁ

Como usuario de un polipasto y carro de COFFING le aseguramos cualquier reparación o la disponibilidad de cualquier pieza de repuesto a través de una red de almacenes de piezas de repuesto y centros de servicio situados estratégicamente en Estados Unidos y Canadá. Estas instalaciones se han seleccionado en base a su capacidad demostrada en la reparación de equipos y suministro de piezas de repuesto de forma rápida y eficaz. Para obtener la dirección del almacén de piezas de repuesto o del centro de servicio más cercano, llame al teléfono (800) 888-0985. Fax: (716) 689-5644, visita www.cmworks.com (sólo en Estados Unidos y Canadá).

LE SERVICE DE RÉPARATION ET DE PIÈCES POUR PALANS COFFING EST DISPONIBLE AUX ÉTATS-UNIS ET AU CANADA

Soyez assurés qu'en temps d'utilisateur de palan et treuil COFFING, d'un service de réparation et de pièces fiable par l'entremise d'un réseau de Centres de service et de Dépôts de pièces maîtresses qui sont stratégiquement situés aux États-Unis et au Canada. Ces établissements ont été sélectionnés sur une base de leur habileté démontrée à s'occuper promptement et efficacement des besoins de réparation de pièces. Appelez le (800) 888-0985, Fax: (716) 689-5644, visite www.cmworks.com pour obtenir rapidement le nom du dépôt de pièces maîtresses ou du centre de service situé le plus près.

WARNING

Improper operation of a hoist can create a potentially hazardous situation which, if not avoided, could result in death, or serious injury. To avoid such a potentially hazardous situation, THE OPERATOR SHALL:

1. **NOT** operate a damaged, malfunctioning or unusually performing hoist.
2. **NOT** operate the hoist until you have thoroughly read and understood manufacturer's Operating and Maintenance Instructions or Manuals.
3. **NOT** operate a hoist which has been modified without the manufacturer's approval or without certification that it is in conformity with ANSI/ASME B30 volumes.
4. **NOT** lift more than rated load for the hoist.
5. **NOT** use hoist with twisted, kinked, damaged, or worn load chain.
6. **NOT** use the hoist to lift, support, or transport people.
7. **NOT** lift loads over people..
8. **NOT** operate a hoist unless all persons are and remain clear of the supported load.
9. **NOT** operate unless load is centered under hoist.
10. **NOT** attempt to lengthen the load chain or repair damaged load chain.
11. Protect the hoists load chain from weld splatter or other damaging contaminants.
12. **NOT** operate a hoist when it is restricted from forming a straight line from hook to hook in the direction of loading.
13. **NOT** use load chain as a sling or wrap load chain around load.
14. **NOT** apply the load to the tip of the hook or to the hook latch.
15. **NOT** apply load unless load chain is properly seated in the chain sprocket(s).
16. **NOT** apply load if bearing prevents equal loading on all load supporting chains.
17. **NOT** operate beyond the limits of the load chain travel.
18. **NOT** leave load supported by the hoist unattended unless specific precautions have been taken.
19. **NOT** allow the chain or hook to be used as an electrical or welding ground.
20. **NOT** allow the chain or hook to be touched by a live welding electrode.
21. **NOT** remove or obscure the warnings on the hoist.
22. **NOT** operate a hoist on which the safety placards or decals are missing or illegible.
23. **NOT** operate a hoist unless it has been securely attached to a suitable support.
24. **NOT** operate a hoist unless load slings or other approved single attachments are properly sized and seated in the hook saddle.
25. Take up slack carefully - make sure load is balanced and load holding action is secure before continuing.
26. Shut down a hoist that malfunctions or performs unusually and report such malfunction.
27. Make sure hoist limit switches function properly.
28. Warn personnel of an approaching load.

CAUTION

Improper operation of a hoist can create a potentially hazardous situation which, if not avoided, could result in minor or moderate injury. To avoid such a potentially hazardous situation, THE OPERATOR SHALL:

1. Maintain a firm footing or be otherwise secured when operating the hoist.
2. Check brake function by tensioning the hoist prior to each lift operation.
3. Use hook latches. Latches are to retain slings, chains, etc. under slack conditions only.
4. Make sure the hook latches are closed and not supporting any parts of the load.
5. Make sure the load is free to move and will clear all obstructions.
6. Avoid swinging the load or hook.
7. Make sure hook travel is in the same direction as shown on the controls.
8. Inspect the hoist regularly, replace damaged or worn parts, and keep appropriate records of maintenance
9. Use Coffing Hoists recommended parts when repairing the unit.
10. Lubricate load chain per hoist recommendations.
11. **NOT** use the hoist's overload limiting clutch to measure load.
12. **NOT** use limit switches as routine operating stops. They are emergency devices only..
13. **NOT** allow your attention to be diverted from operating the hoist.
14. **NOT** allow the hoist to be subjected to sharp contact with other hoists, structures, or objects through misuse.
15. **NOT** adjust or repair the hoist unless qualified to perform such adjustments or repairs.

SAFETY PRECAUTIONS

Each Coffing JLC Series Electric Chain Hoist is built in accordance with the specifications contained herein and at the time of manufacture complies with our interpretation of applicable sections of *American Society of Mechanical Engineers Code (ASME) B30.16 "Overhead Hoists," the National Electrical Code (ANSI/NFPA 70) and the Occupational Safety and Health Act (OSHA). Since OSHA states the National Electrical Code applies to all electric hoists, installers are required to provide current overload protection and grounding on the branch circuit section in keeping with the code. Check each installation for compliance with the application, operation and maintenance sections of these articles.

*Copies of this standard can be obtained from ASME Order Department, 22 Law Drive, PO Box 2300, Fairfield, NJ 07007- 2300, U.S.A., www.asme.org, 800-843-2763.

HOIST SAFETY IS UP TO YOU...

⚠ WARNING
DO NOT LIFT MORE THAN RATED LOAD.

CHOOSE THE RIGHT HOIST FOR THE JOB...

Choose a hoist with the capacity for the job. Know the capacities of your hoists and the weight of your loads. Then match them.

The application, the size and type of load, the attachments to be used and the period of use must also be taken into consideration in selecting the right hoist for the job.

Remember, the hoist was designed to ease our burden and carelessness not only endangers the operator, but in many cases, a valuable load.



⚠ WARNING
DO NOT OPERATE DAMAGED OR MALFUNCTIONING HOIST
DO NOT OPERATE WITH TWISTED, KINKED, OR DAMAGED CHAIN.

INSPECT

All hoists should be visually inspected before use, in addition to regular, periodic maintenance inspections.

Inspect hoists for operations warning notices and legibility.

Deficiencies should be noted and brought to the attention of supervisors. Be sure defective hoists are tagged and taken out of service until repairs are made.

Under no circumstances should you operate a malfunctioning hoist.

Check for gouged, twisted, distorted links and foreign material. Do not operate hoists with twisted, kinked, or damaged chain links.

Load chain should be properly lubricated.

Hooks that are bent, worn, or whose openings are enlarged beyond normal throat opening should not be used. If latch does not engage throat opening of hook, hoist should be taken out of service.

Chains should be checked for deposits of foreign material which may be carried into the hoist mechanism.

Check brake for evidence of slippage under load.

⚠ WARNING
Violations of any of the warnings listed may result in serious personal injury to the operator or nearby personnel by nature of released load or broken hoist components.

⚠ WARNING
DO NOT PULL AT AN ANGLE. BE SURE HOIST AND LOAD ARE IN A STRAIGHT LINE.
DO NOT USE LOAD CHAIN AS A SLING.

USE HOIST PROPERLY

Be sure hoist is solidly held in the uppermost part of the support hook arc.

Be sure hoist and load are in a straight line. Do not pull at an angle.

Be sure load is hooked securely. Do not tip load the hook. Do not load hook latch. Hook latch is to prevent detachment of load under slack chain conditions only.

Do not use load chain as a sling. Such usage damages the chain and lower hook.

Do not operate with hoist head resting against any object. Lift the load gently. Do not jerk it.



⚠ WARNING
DO NOT LIFT PEOPLE OR LOADS OVER PEOPLE

LIFT PROPERLY

Do not lift co-workers with a hoist.

Make sure everyone is clear of the load when you lift.

Do not remove or obscure operational warning notices.



MAINTAIN PROPERLY

CLEANING

Hoists should be kept clean and free of dust, dirt, moisture, etc., which will in any way affect the operation or safety of the equipment.

LUBRICATION

Chain should be properly lubricated.

AFTER REPAIRS

Carefully operate the hoist before returning it to full service.



FOREWARD

This manual contains important information to help you properly install, operate and maintain your hoist for maximum performance, economy and safety.

Please study its contents thoroughly before putting your hoist into operation. By practicing correct operating procedures and by carrying out the recommended preventive maintenance suggestions, you will experience long, dependable and safe service. After you have completely familiarized yourself with the contents of this manual, we recommend that you carefully file it for future reference. The information herein is directed to the proper use, care and maintenance of the hoist and does not comprise a handbook on the broad subject of rigging.

Rigging can be defined as the process of lifting and moving heavy loads using hoists and other mechanical equipment. Skill acquired through specialized experience and study is essential to safe rigging operations. For rigging information, we recommend consulting a standard textbook on the subject.

TABLE OF CONTENTS

SAFETY PRECAUTIONS	
Operating and Safety Procedures	2
Foreword	3
GENERAL INFORMATION	
Safety Standards.....	4
Basic Hoist Data.....	4
Application Information	4
Warranty	4
SPECIFICATIONS	5
INSTALLATION	
Chain Container.....	5
Installation of Standard Chain Container	6
OPERATION	
Overload Limiting Protection.....	7
MAINTENANCE	
Inspections.....	7
Lowering Without Power	7
Hooks	7
Chains	8
Limit Switch Adjustment	9
Brake	9
Hoist Controls.....	10
Wiring	10
Lubrication.....	10
Hoist Repairs.....	10
Power Cord Precautions with 1-Phase Hoists	12
TROUBLESHOOTING	13
WIRING	15
INSPECTION	17
REPAIR PARTS	
Ordering Information	20

LIST OF TABLES

TABLE	DESCRIPTION	PAGE
1	Hoist Specifications	5
2	Motor Amperage of 1-Speed Hoist Models	5
3	Motor Amperage of 2-Speed Hoist Models	5
4	Chain Containers	6
5	Recommended Conductor Sizes for 1-Phase Hoist	12
6	Troubleshooting	13-14

LIST OF ILLUSTRATIONS

FIG.	DESCRIPTION	PAGE
1	Installing Chain Container Assembly	6
2	Hook Inspection.....	7
3	Limit Switch Assembly.....	8
4	Chain Replacement Diagram.....	9
5	Brake Assembly	10
6	Electrical Panel Removed	10
7	Assembled Gearing	11
8a	Single Chain Lub Oriented.....	12
8b	Single Chain Hook Orientation	12
8c	Double Chain Hook Orientation.....	12
9a	Wiring Diagram for 115/230V 1 Phase Models.....	15
9b	Wiring Diagram for 1- Speed, 230/460V - 3 Phase Models	15
9c	Wiring Diagram for 1- Speed, 208V & 575V 3 Phase Models	16
9d	Wiring Diagram for 2-Speed, 3 Phase Models	16
10a	Recommended Inspection and Maintenance Checklist .	18
10b	Recommended Inspector's Report	19
11	Recommended Lubrication Schedule	19
12	Basic Hoist	21
13	Hoist Motor, 115/230V — 1 Phase	22
14	Hoist Motor — 3 Phase	23
15	Brake & Solenoid Parts	24
16	Electrical Parts — 1 Speed Models	25
17	Electrical Parts — 2 Speed Models	26
18	1 Speed Pushbutton Station	27
19	2 Speed Pushbutton Station	28
20	Coffing Rocket Universal Pendant Control	29-30
21	Limit Switch Assembly	31
22	Long Lift Limit Switch Parts	32
23	Transmission	33-34
24	Chaining Parts	35-36

SECTION I – INTRODUCTION

1-1 GENERAL INFORMATION

INSPECTION

This manual provides information for the safe operation and maintenance of Coffing® JLC Series Hoists. All persons operating or maintaining these hoists should be familiar with the information contained herein. Adherence to the precautions, procedures, and maintenance practices described should ensure long reliable operation. Suggestions for improvements to this manual are solicited.

CAUTION

To safeguard against the possibility of personal injury or property damage, follow the recommendations and instructions of this manual. This manual contains important information for the correct installation, operation, and maintenance of this equipment. All persons involved in the installation, operation, and maintenance of this equipment should be thoroughly familiar with the contents of this manual. Keep this manual for reference and further use.

WARNING

To avoid personal injury:

Do not use the equipment shown in this manual to lift, support, or otherwise transport people, or to suspend unattended loads over people.

1-2 SAFETY STANDARDS

All persons concerned with the installation, operation, inspection and maintenance of these hoists are urged to read ASME B30.16. That Standard contains valuable guidelines concerning practices designed to minimize hazards associated with the use of overhead hoisting equipment. ASME B30.16 also contains detailed procedures for establishing hoist inspection and maintenance programs and can be of significant assistance in maintaining compliance with OSHA regulations.

1. Follow all local electrical and safety codes, as well as the National Electrical Code (NEC) and the Occupational Safety and Health Act (OSHA) in the United States.
2. Hoist must be securely and adequately grounded. Hoist power cable is provided with an additional lead (green) for grounding purposes.

WARNING

Always disconnect power source before working on or near a hoist or its connected load. If the power disconnect point is out of sight, lock it in the open position and tag to prevent unexpected application of power.

3. Be careful when touching the exterior of an operating motor; it may be hot enough to be painful or cause injury. With modern motors this condition is normal if operated at rated load and voltage (modern motors are built to operate at higher temperatures).
4. Protect the power cable and control cable from coming in contact with sharp objects.
5. Do not kink power cable and control cable and never allow the cable to come in contact with oil, grease, hot surfaces, or chemicals.
6. Make certain that the power source conforms to the requirements of your equipment.
7. Inspect the unit daily before operating the hoist.
8. Cluttered areas and benches invite accidents.
9. The operator should not engage in any practice which will divert his attention while operating the hoist.

10. Before using the hoist, the operator should be certain that all personnel are clear.
11. Do not operate hoist with loads exceeding its rated capacity.
12. Supporting frames or beams used as a hoist hanger must have a greater load capacity than the hoist.
13. Do not attempt to operate the hoist beyond normal maximum lift range.
14. Align hoist for a straight line pull. Avoid side pull or end pull.
15. Do not operate hoist with twisted or damaged chain.
16. Do not operate a damaged or malfunctioning hoist until necessary adjustments or repairs have been made.
17. Do not use hoist to lift people or to carry loads over people.
18. Do not leave a load suspended in the air unattended.
19. Always remove load before making repairs.
20. Do not remove or obscure capacity or warning decals

1-3 BASIC HOIST DATA

The basic hoist models covered by this manual are listed in Table 1.

1-4 APPLICATION INFORMATION

This hoist is intended for general industrial use in the lifting and transporting of freely suspended material loads within its rated load. Prior to installation and operation, the user should review his application for abnormal environmental or handling conditions and to observe the applicable recommendations as follows:

- a. **Adverse Environmental Conditions.** Do not use the hoist in areas containing flammable vapors, liquids, gases or any combustible dusts or fibers. Refer to Article 500 of The National Electric Code. Do not use this hoist in highly corrosive, abrasive or wet environments. Do not use this hoist in applications involving extended exposure to ambient temperatures below -10°F or above 130°F.
- b. **Lifting of Hazardous Loads.** This hoist is not recommended for use in lifting or transporting hazardous loads or materials which could cause widespread damage if dropped. The lifting of loads which could explode or create chemical or radioactive contamination if dropped requires fail-safe redundant supporting devices which are not incorporated into this hoist.
- c. **Lifting of Guided Loads.** This hoist must not be used in the lifting of guided loads, including dumbwaiters, non-riding elevators and elevators. Such applications require additional protective devices which are not incorporated into this hoist. Refer to your state and local regulations governing and the American National Safety Code for elevators, dumbwaiters, escalators and moving walks (ASME A17.1).

1-5 WARRANTY

Every hoist is thoroughly inspected and tested prior to shipment from the factory. Should any problems develop, return the complete hoist prepaid to your nearest Coffing Authorized Warranty Repair Station. If inspection reveals that the problem is caused by defective workmanship or material, repairs will be made without charge and the hoist will be returned, transportation prepaid.

This warranty does not apply where: (1) deterioration is caused by normal wear, abuse, improper or inadequate power supply, eccentric or side loading, overloading, chemical or abrasive actions, improper maintenance or excessive heat; (2) problems resulted from repairs, modifications or alterations made by persons other than factory or Coffing Authorized Warranty Repair Station personnel; (3) the hoist has been abused or damaged as a result of an accident; (4) repair parts or accessories other than those supplied by Coffing are used on the hoist. Equipment and accessories not of the seller's manufacture are warranted only to the extent that they are warranted by the manufacturer. EXCEPT AS STATED HEREIN, COFFING MAKES NO OTHER WARRANTIES, EXPRESS OR IMPLIED, INCLUDING WARRANTIES OF MERCHANTABILITY AND FITNESS FOR A PARTICULAR PURPOSE.

SECTION II – SPECIFICATIONS

Coffing JLC series electric chain hoists are rugged, portable hoists that provide quick, precise lifting. The hoists are constructed of tough, but lightweight, die cast aluminum alloy housings. An oil bath transmission, equipped with heat-treated, alloy steel gears and an overload limiting clutch, provides smooth and reliable operation. With a pushbutton station that fits comfortably in one hand, the operator can safely control the hoist while the other hand is free to guide the load. The electrical controls use a low voltage circuit (24V standard, 115V optional). Terminal blocks allow for easy voltage conversions on dual-voltage models.

Other features that ensure the safe operation of Coffing electric chain hoists include a magnetic disc brake that delivers sure stopping and secure holding of the load. Adjustable upper and lower limit switches regulate the load travel. As a standard, hooks are supplied with safety latches. For additional safety, a chain stop is attached to the slack end of the load chain.

Coffing electric chain hoists are designed and tested in accordance with the American Society of Mechanical Engineers Code B30.16, "Safety Standard for Overhead Hoists." Hoists are built in compliance with CSA, file number LR 44484. Made in U.S.A.

Table 1 - Hoist Specifications

Model	Hoist Capacity (lbs)	Lifting Speed (rpm)	HP	Reeving
JLC0232	250	32	1/4 1/2	Single-Chain
JLC0516	500	16	1/2	Single-Chain
JLC0532	500	32	1/2	Single-Chain
JLC1016	1000	16	1/2	Single-Chain
JLC1032	1000	32	1	Single-Chain
JLC2016	2000	16	1	Single-Chain
JLC4008	4000	8	1	Double-Chain

*Note: JLCET models are equivalent to the corresponding JLC, but are supplied with a push-type trolley. Reference in this manual to JLC models also applies to JLCET models.

Table 2 - Motor Amperage of 1-Speed Hoist Models

Hoist HP	Full Load Amps			
	1-Phase 115/230V	3-Phase		
		208V	230/460V	575V
1/4	N/A	1.9	1.7/.85	.7
1/2	8.4/4.2	2.3	2.1/1.05	.7
1	14.8/7.4*	4.6	3.9/1.95	1.6

* The 1HP, 115/230V models (JLC1032-1, JLC2016-1, JLC4008-1) must have a dedicated power circuit rated for at least 20A, 125V when they are wired for 115V. It is not unusual for these models to draw up to 20 amps at 115V when lifting at rated capacity depending on the quality of the voltage source.

Table 3 - Motor Amperage of 2-Speed Hoist Models

Hoist HP (fast/slow)	Full Load Amps for 3 Phase Only (fast/slow)			
	208v	230V	460V	575V
0.25/0.083	2.0/1.9	2.2/2.2	0.9/0.9	0.64/0.71
0.5/0.17	3.8/3.2	3.7/3.0	1.35/1.25	1.15/1.05
1/0.33	4.6/5.8	5.0/3.5	2.25/1.55	2.1/1.4

NOTE: The above data is the nominal motor current at full load. At full load, it is not unusual for the hoist to draw in excess of the values listed when lifting. It is critical to ensure that the voltage at the reversing contactor does not drop more than 10% below the nominal voltage while lifting a load. Low voltage will result in higher amp draw, damage to the hoist, and potential fire hazards. Coffing Hoists is not responsible for any damages caused by an inadequate power source.

WARNING

Failure to comply with Safety precautions outlined throughout this manual can result in serious injuries or death. Before using this hoist, each operator should become thoroughly familiar with all warnings, instructions and recommendations in this manual.

SECTION III – INSTALLATION

- Before installing the hoist, check the following:
 - Make sure all supporting structures and attaching devices are strong enough to hold your intended loads. If in doubt, consult a qualified structural engineer.
 - Provide proper branch circuit protection for the hoist as recommended in the National Electrical Code.
 - The power supply should be plus or minus 10% of the voltage specified on the motor nameplate. It is critical to use adequate sized power cables, especially with 1-phase hoists (**See Table 5, page 11**). Be sure dual voltage hoists are connected or wired to correspond with your power supply (See WIRING, page 9).
 - Installation area must provide operating conditions for the operator including sufficient room for the operator and other personnel to stand clear of the load at all times.
 - For installations where the slack chain hanging from the unit may be objectionable or hazardous, the use of a chain container is recommended (See CHAIN CONTAINER, page 5).
- JLCET models come with a Coffing ETB push-type trolley and an adaptable suspension lug. ETB trolleys are made to run on American Standard I-Beams and Wide Flange Beams with flange widths up to 8". For assembly refer to the instructions provided with the trolley. The hoist lug must be centered with the sideplates (± 1 washer). Due to the lug thickness, the washer placement between each sideplate and the lug may differ by 1 less washer than the generic instructions specify. For installations where the trolley can not be slid onto the end of a beam, leave the load pin nuts loose enough to get the wheels around the beam flange. Check the flange width setting before tightening the nuts to **125 ft-lbs**. Be sure to have end stops on your beam.
- Before operating the hoist, be sure to observe the following:
 - ALWAYS DISCONNECT HOIST FROM POWER SUPPLY before removing electrical cover or when making any electrical connection in the hoist or pushbutton station.
 - The ground wire (green colored) of the power cable should always be connected to a suitable ground by means of a screw or clamp. An alligator clip does not make a safe ground connection.
 - When installing a three-phase hoist, make only temporary connections at the power source. Push the "UP" button and observe the direction of the load block. If it raises, the phasing is correct and permanent connections may be made at the power source. If the load block lowers when the "UP" button is pushed, release the button immediately since the limit switches will not operate to protect the hoist from over-travel. Reverse any two wires (except the green ground wire) at the power source to correct the load hook direction (phasing). Do not change connections in the hoist or pushbutton assembly.
 - Make sure load chain is not twisted as it travels into the hoist.
 - Operate hoist in a hanging position only. Hoist should be permitted to align itself for a straight line pull. Do not attempt to pull around corners.
 - Read ASME-B30.16 Safety Code for Hoists.
- Lubricate the chain as necessary, see LUBRICATION, page 9.
- Check the function of the limit switches. Before placing hoist in operation, check limit switch settings. Operate pushbutton until near stop point and inch into stop limit, both top and bottom. If either switch is not correct, adjust according to LIMIT SWITCH ADJUSTMENT, page 8.

CHAIN CONTAINER (OPTIONAL ACCESSORY)

Refer to Table 4.

For installations where the slack chain hanging from the hoist may be objectionable or hazardous, the use of a chain container is recommended.

Available chain containers include the standard containers designed for lifts of up to 50 ft on single-chained hoists and 25 ft on double-chained hoists. For longer lifts, the JLC927-4 container is available. For applications where a fabric bag is preferred, the JLC927-20F, JLC927-35F and the JLC927-50F are all options.

⚠ WARNING

Do not attempt to store more chain in chain container than that specified in the table below. Failing to do so may cause serious hoist damage and hazardous conditions that may result in injury or death.

Instructions are provided with each of these chain containers and must be adhered to closely to ensure a proper installation. To install the long lift chain container or a fabric chain container, you must follow instruction sheets provided with the chain container. The following instructions are for the standard JLC927-1 chain container only..

INSTALLATION OF STANDARD CHAIN CONTAINER (JLC927-1)

Refer to Figure 1.

1. Remove retaining clip and attachment pin and let the slack chain hang free.
2. Run load hook down to its lowest position. Place the slack end of chain in chain container. Do not remove the chain stop.
3. Place chain container flush against housing with chain stripper between top lugs. Insert long attachment pin and replace

retaining clip.

4. Feed the remainder of chain into container by operating hoist in the "UP" direction to the top limit. This will permit the chain to pile freely and prevent the chain from kinking, which may occur if the chain is placed in the container by hand.

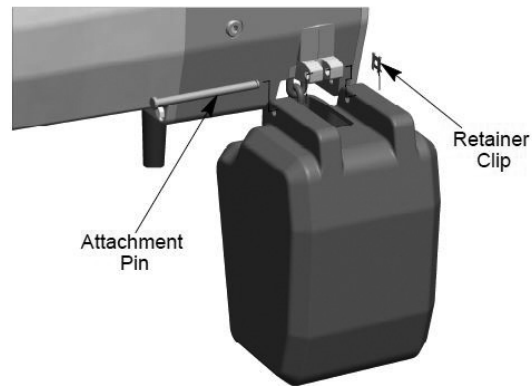

Figure 1 — Installing Chain Container Assembly

⚠ WARNING

Load chain that is kept clean and lubricated is essential to the safe operation of a hoist with a chain container. Failure to do so may cause serious hoist damage, spillage of chain from container, cross-linked chain resulting in dropped load and other hazardous conditions that may result in injury or death.

Table 4 - Chain Containers

Chain Container Model	Recommended for Use With:		Dimensions in Inches			
	Hoist Capacity	Maximum Lift	Container Material	Width	Length	Depth
JLC927-1*	1 Ton & Under 2 Ton	20 10	Molded Container	6 7/8"	6 1/2"	10 3/8"
JLC927-2**	1 Ton & Under 2 Ton	35 17	Molded Container	6 1/2"	6 1/2"	15 3/4"
JLC927-3**	1 Ton & Under 2 Ton	50 25	Molded Container	6 1/2"	6 1/2"	20 1/4"
JLC927-4**	1 Ton & Under 2 Ton	143 71	Steel or Molded Container	6 1/2"	6 1/2"	34 "
JLC927-20F**	1 Ton & Under 2 Ton	20 10	Open Weave Vinyl Coated Polyester	7 1/2"	7 1/2"	16"
JLC927-35F**	1 Ton & Under 2 Ton	35 17	Open Weave Vinyl Coated Polyester	7 1/2"	7 1/2"	22
JLC927-50F**	1 Ton & Under 2 Ton	50 25	Open Weave Vinyl Coated Polyester	7 1/2"	7 1/2"	26
JLC927-70F**	1 Ton & Under 2 Ton	70 35	Open Weave Vinyl Coated Polyester	7 1/2"	7 1/2"	31

*Standard container included with hoist with 20 ft max.,single line ot 10ft Max double line hoist only.

**All other chain containers sold separately.

SECTION IV — OPERATION

4-1 GENERAL

This hoist is designed for safe operation within the limits of its rated capacity. It is controlled by the “UP” and “DOWN” buttons of the pushbutton station. Two-speed models utilize 2-step buttons, the first step for operating the slow speed and the second for the fast speed. Although the Coffing JLC is built with many features to ensure safety, it is a requirement that a hoist operator understands safe lifting practices. The following points must be observed.

CAUTION

Do not allow load to come in contact with the chain container. If this situation exists reset the “UP” limit switch so that the hook block stops below the chain container (See LIMIT SWITCH ADJUSTMENT, page 8).

1. Do not overload the hoist.
2. Do not make extreme side pulls with the hoist.
3. Operate the hoist only in a hanging position with adequate support.
4. Do not “sling” the load hook and chain around the load. Use an approved sling.
5. Be sure there are no twists in the load chain as it travels into the hoist housing. This condition should be constantly checked on double chain hoists because it is possible for the load block to be “capsized” or turned over one or more times.
6. Before raising a load, always check to see that it is held securely in the hook or sling chains, etc. Raise the load only until the load chain is taut and then double check the rigging before continuing to raise the load.
7. Do not stand beneath a load! Do not move a load in such a manner as to endanger personnel.

WARNING

To avoid personal injury:

Do not use the equipment shown in this manual to lift, support, or otherwise transport people, or to suspend loads over people.

8. Don't lower into areas where visibility is obscured unless someone else is guiding the operation.
9. Use common sense at all times when operating a hoist.
10. Do not operate if direction of hook travel is not the same as indicated on button being pushed.
11. Do not operate unless hook travel limit devices function. Test without load each shift.
12. Do not operate when hoist is not centered over load.
13. Do not operate if chain is not seated properly in sprockets or sheave grooves.
14. Do not operate damaged or malfunctioning hoist.

4-2. OVERLOAD LIMITING PROTECTION

This hoist is equipped with a factory-calibrated overload limiting clutch that will permit the lifting of loads within its rated capacity, but will prevent the lifting of damaging overloads while the hoist is being operated. If the load being lifted exceeds the lifting capability of the overload clutch, the hoist motor will continue to run, causing overheating of both the clutch and hoist motor. This condition should be avoided by immediately releasing the “UP” button and reducing the load to within the rated capacity of the hoist. See GEARING, page 10, for additional instructions on this device.

CAUTION

The overload limiting clutch is an emergency protective device and should not be used to measure the maximum load to be lifted, or to sense the overload imposed by a constrained load. While the overload limiting clutch will protect the hoist from damaging overloads, it will not ensure that a load is within the rated capacity of the hoist.

SECTION V — MAINTENANCE

5-1. INSPECTIONS

A planned inspection routine should be established for this hoist based upon frequency of use, severity of use, and environmental conditions (Reference ASME Standard B30.16). Some inspections should be made frequently (daily to monthly) and others periodically (monthly to yearly). It is strongly recommended that an Inspection and Maintenance Check List and an Inspector's Report, similar to those shown in Figures 10A and 10B, be used and filed for reference. All inspections should be performed or overseen by a designated inspector. Special inspections should be made following any significant repairs or any operating occurrence leading one to suspect that the hoist's capability may have been impaired

5-2. LOWERING WITHOUT POWER

If the power fails with a load suspended, the hoist will automatically stop. In an emergency the load can be lowered without power as follows:

1. DISCONNECT HOIST FROM POWER SUPPLY AND REMOVE ELECTRICAL COVER.
2. Refer to Figure 5. Open disc brake manually by using two screwdriver blades, one on each side of the brake at a point close to the brake spring posts. Apply pressure to the underside of the armature plate (points “X”) to close the solenoid and release the brake.
3. Use several quick releases instead of holding brake open continuously. Do not exceed normal lowering speed.

WARNING

Do not allow screwdriver blades to touch rotating friction disc “C”.

CAUTION

Do not allow the load to descend rapidly. This causes the motor to race and serious damage may result.

5-3. HOOKS

Refer to Figure 2.

1. Inspect hooks once daily for cracking, extreme wear or spreading. Replace hooks showing any of these signs. If the throat openings are spread wider than the maximum permissible 15% increase listed here, the hooks have been overstressed and must be replaced. Any hook that is bent or twisted more than 10 degrees from the plane of an unbent hook must also be replaced.
2. The hook latches should be inspected to ensure that they close the hook throat opening in a secure manner when a load is applied. Inspect the hook shank and nut for any stripping of the threads or other damage. The hook nut should be fully restrained by the retaining pin.
3. In addition to above, load hooks should be inspected for cracks by the magnetic particle, dye penetrant or other suitable crack testing inspection method. This should be done at least once a year.

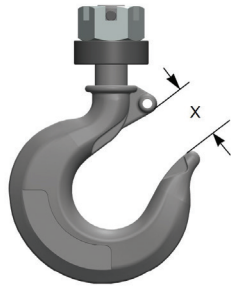

Figure 2 – Hook Inspection

Hoist Capacity	"X" Dimension	
	Top Hook	Bottom Hook
1 Ton & Under	1-11/32"	1-7/32"
2 Ton	1-11/32"	1-11/32"

(*) Maximum permissible throat opening of hook.

5-4. CHAIN

Chain inspection and lubrication are the most important aspects of hoist maintenance. Chain is to be kept clean and lubricated (See LUBRICATION, page 9) at all times. Visually check the chain every time the hoist is used. Hoist must not be operated when the chain is twisted or kinked. Chain inspection will not usually require removal of the chain from the hoist, but the chain should be run through the hoist enough so that every link is made visible for inspection.

CAUTION

Load chain that is kept clean and lubricated is essential to the safe operation of a hoist. Failure to do so may cause serious hoist damage, spillage of chain from chain container (when equipped), cross-linked chain resulting in dropped loads and other hazardous conditions that may result in injury or death. Chain contaminated with foreign substance must be removed from service, cleaned and lubricated before hoist use can continue.

- Check each link for gouges, nicks, weld splatter, corrosion, and distortion.
- Inspect each link for wear to the diameter of the link. The nominal link diameter is 0.281 inch. If the diameter of any link of 0.281 chain is worn to less than 0.225 inch, the entire chain must be replaced.

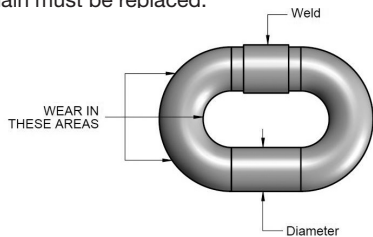

1. Check the chain for overall wear or stretch by selecting an unworn, unstretched length of chain (at the slack end, for example). Let the chain hang vertically with a light load (about 20 pounds) on the chain to pull it taut. Use a large caliper to measure the outside length of a convenient number of links (about 12 inches). Measure the same number of links in a used section of chain and calculate the percentage increase in length of the worn chain.
2. If the length of the worn chain is more than 1-1/2% longer than the unused chain (0.015 inch per inch of chain measured), then the chain should be replaced. If the chain is worn less than 1-1/2%, check it at several more places along its length. If any section is worn more than 1-1/2%, the chain should be replaced.
- The chain used in the hoist is accurately calibrated to operate over the load sprocket and is very carefully heat treated for maximum wear life and strength.

WARNING

Do not weld or join hoist load chain. Do not substitute another manufacturer's chain in this hoist. Damage or wear, beyond the stated limits, to any portion of the chain requires that the entire length of chain be replaced.

CHAIN REPLACEMENT WITH CHAIN IN HOIST

Refer to Figures 3 & 4.

- Run hook up to its top limit.
- DISCONNECT HOIST FROM POWER SUPPLY and remove the electrical cover.
- Using a screwdriver, pry the spring guide plate out of the slots in the limit switch nuts (See Figure 3). Turn the gold nut back to about the center of the threaded screw. Do not disconnect the wires from the limit switches.
- Remove the load block assembly from the old chain. On double-chained hoists detach the chain from the chain support and pull it through the load block assembly (See Figure 4).
- Make a "C" shaped chain link by grinding through the end link on the load end of the old chain.
- Using the "C" link, attach the new chain to the load end of the old chain. Be sure that the welds of the upstanding links of the new chain will face outward from the load sheave. The end links must be oriented for attachment to the dead-end attachment pin and the chain support (double-chained only) without any twist in the chain. (See Figure 23)
- With the electrical cover off, connect the hoist to the power supply. Be sure that the green ground wire is properly grounded (See INSTALLATION 3b, page 4).
- Carefully jog the "UP" button and run the joined pieces of chain into the hoist until about 15" of the new chain comes out the other side.
- DISCONNECT HOIST FROM POWER SUPPLY.
- Remove the "C" link and the old chain. Remove the chain stop by prying off its retaining ring with a flathead screwdriver. If attached, remove the old chain from the chain stripper by removing the retainer clip and attachment pin.
- Attach the chain stop to the slack end of the new chain by capturing the 12th link with the two stop halves positioned with their tapered ends pointing towards the hoist. Slide the sleeve over the halves and attach the retaining ring. If you are not using a chain container, attach the slack end of the new chain to the side of the hoist using the attachment pin and retainer clip. DO NOT allow twists in the chain.
- Adjust the lower limit switch (See ADJUSTING LOWER LIMIT, page 8).
- Attach the bottom block on single-chained hoists using a **new load block pin** (See Figure 23). On double-chained hoists, feed the chain through the load block (welds of the upstanding links will be in towards the sheave) and fasten the end of the chain to the chain support using a **new chain support pin** (See Figure 23). **Be sure there are no twists in the chain.**
- Adjust the upper limit switch (See ADJUSTING UPPER LIMIT, page 8).

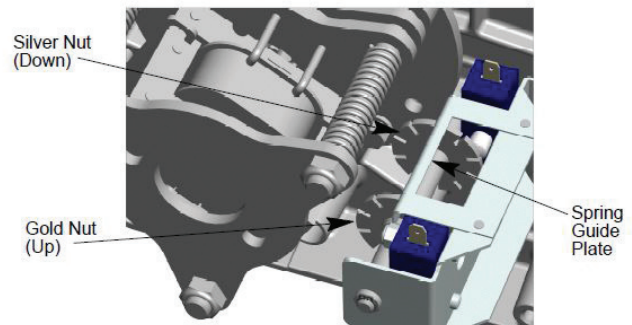

Figure 3 – Limit Switch Assembly

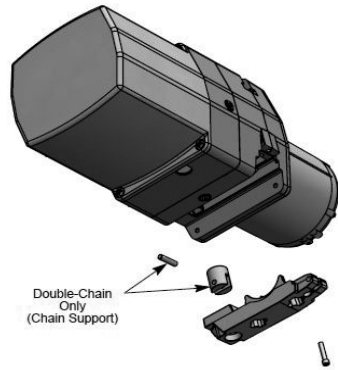

Figure 4 – Chain Replacement Diagram

CHAIN REPLACEMENT WITH NO CHAIN IN HOIST

Refer to Figure 4.

1. DISCONNECT HOIST FROM POWER SUPPLY and move hoist to a work table. Remove the electrical cover, electrical panel and the electric brake assembly.
2. Detach the chain stripper from the bottom of the hoist.
3. Insert the new chain between the load sheave and the chain guide. Feed the chain into the hoist by manually turning the brake hub adaptor. Allow about 15" of chain below the hoist on the slack end. Be sure the welds of the upstanding links are out away from the load sheave and that proper orientation is observed for attachment of the slack end. Also be sure the load hook assembly (if already attached to the chain) is toward the center of the hoist or to your right looking from the motor end.
4. Reinstall the chain stripper (with the chain support on double-chained hoists, See Figure 4) observing proper chain alignment and avoiding any twist in the chain.
5. Follow steps 11 through 14 in previous section, CHAIN REPLACEMENT WITH CHAIN IN HOIST, to complete the chain replacement procedure.

NOTE: Inspect chain guides and load sheave for wear, replace as needed.

5-5 LIMIT SWITCH ADJUSTMENT

IMPORTANT: Before placing hoist in operation, check the limit switch adjustment. Limit switches are provided to protect the hoist against damage resulting from overtravel or to allow setting the hook travel within the factory-set limits of travel. The standard limit switch is designed for lifts of 50 ft or less on single-chained hoists and 25 ft or less on the 2 ton, double-chained models. The long lift limit switch allows for the maximum amount of lift, which is 143 ft on the 1 ton and under models, and 71 ft on the 2 ton models.

The upper and lower limit switch adjusting nuts are color-coded gold and silver respectively. Each limit nut has 10 slots for fine adjustment, and the increment of adjustment is such that one slot is equivalent to approximately one link of chain travel with the standard limit switch. Movement of the limit switch nuts toward or away from each other decreases or increases the hook travel respectively.

ADJUSTING UPPER LIMIT (GOLD NUT)

Refer to Figure 3.

1. Suspend the hoist. For single chain models raise the load block until there is a minimum clearance of 2" from the hoist housing and the top of the block. Double chain models require a minimum clearance of 1" from the chain support to the top of the load block.
2. DISCONNECT HOIST FROM POWER SUPPLY and remove the electrical cover.
3. With a screwdriver, pry the spring guide plate out of the slots in the limit switch nuts.
4. Turn the slotted gold nut toward its limit switch until the switch

"clicks" then turn two slots farther. Release the spring guide plate and be sure it slips back into the slots in both limit switch nuts. Do not disturb the silver slotted nut if it has been set previously.

ADJUSTING LOWER LIMIT (SILVER NUT)

Refer to Figure 3.

1. Suspend the hoist. Carefully lower the load block to a point where the slack-end loop of the chain hangs down 6" or more from the hoist housing (or the limit desired in any particular application allowing the minimum 6"). There should be a minimum clearance of 1-1/2" between the chain stop and bottom of hoist.
2. DISCONNECT HOIST FROM POWER SUPPLY and remove the electrical cover.
3. With a screwdriver, pry the spring guide plate out of the slots in the limit switch nuts.
4. Turn the slotted silver nut toward its limit switch until the switch "clicks," then turn two slots farther. Release the spring guide plate and be sure it slips back in the slots in both limit switch nuts. Do not disturb the gold slotted nut if it has been set previously.

CHECK BOTH UPPER AND LOWER LIMITS

1. Connect the hoist to the power supply. Be sure the green ground wire is properly grounded (See Installation 3-b, page 5).
2. Check load hook direction (See Installation 3-c, page 5).
3. Carefully raise load block to upper limit and observe if it stops automatically at desired level. Do not allow load block to run into hoist housing — this will damage the hoist. Maintain a minimum clearance of 2" from the hoist housing and the top of the load block on single-chained models and 1" from the chain support to the top of the load block on double-chained models.
4. Carefully lower load block to lower limit and observe if it stops automatically at the desired level. Do not allow slack-end loop of chain to become taut against hoist housing. This will damage the hoist. There should be a minimum clearance of 1 1/2" between the chain stop and the bottom of the hoist.
5. If upper and lower limits operate satisfactorily, hoist is ready for use. If they are not as desired, repeat adjustment.

CAUTION

If the wires running to the limit switches are ever disconnected for any purpose, be sure to replace wires in accordance with the correct wiring diagram (See Figures 9A, 9B, 9C & 9D).

5-6 BRAKE

Properly adjusted, this brake will release promptly when energized. It is capable of both smoothly stopping and securely holding the rated capacity of the hoist. If the hoist develops either undesirable over-travel after the pushbutton is released (this condition is most noticeable in the lowering direction) or hesitates to lift the load promptly when the pushbutton is depressed (this condition is most noticeable in the hoisting direction), the brake should be adjusted.

BRAKE ADJUSTMENT

Refer to Figure 5.

1. DISCONNECT HOIST FROM POWER SUPPLY and remove the electrical cover.
2. With reference to Figure 5, the gap between the brake armature "A" and the field "B" should be checked. The correct gap is 0.015". Adjustment should not be necessary until gap reaches 0.040".
3. Adjust the gap using a 9/16" wrench on the 3 locknuts "F". Check with a feeler gauge to be sure the gap is the same on both ends of the solenoid.
4. Adjustment is now complete and the brake properly set. Replace the electrical cover, reconnect the power supply, and check hoist brake action.

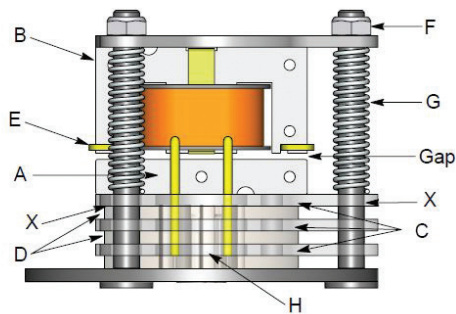

Figure 5 – Brake Assembly

CAUTION

Be sure the bottom of the armature "A" does not bear against the splined adapter "H". As adjustments are made, the built-in clearance will be reduced. When this clearance is gone REPLACE BRAKE DISCS. Minimum allowable disc thickness is .162".

5-7 HOIST CONTROLS

Both the pushbutton and the reversing contactor are mechanically interlocked to prevent shorting the circuit and causing serious damage. As part of maintenance, always check for proper closure of contact points as well as for burned contacts. If replacement is necessary, see Figures 16, 17, 18, and 19 for replacement parts.

5-8 WIRING

Refer to Figures 9A, 9B, 9C & 9D.

Single-phase units (115/230V) are shipped wired for 115V and the 1-speed, 230/460V-3 phase units are wired for 460V unless otherwise specified when ordered. Hoists wired for other voltages and 2-speed units are single voltage only. Conversion of dual-voltage hoists to either the higher or lower voltage can be done simply and quickly as follows:

1. DISCONNECT HOIST FROM POWER SUPPLY and remove the electrical cover.
 2. Each dual-voltage hoist has a terminal block assembly for the interconnection of the electrical components of the hoist. To convert the voltage, reconnect the leads to the terminal blocks according to the wiring diagram located inside the electrical cover or Figures 9A, 9B, 9C and 9D.
- DO NOT move any wires or make any changes to the electrical circuit except at the terminal block assembly. Tug on wires to ensure they are securely connected.**
3. After converting the voltage, recheck phasing and limit switch operation (See INSTALLATION 3-c & 5, page 5).

IMPORTANT: Always refer to the wiring diagram located on the inside of the electrical cover or Figures 9A, 9B, 9C and 9D when performing electrical repairs. Make sure all connections are secure and check for damaged insulation. It is also imperative that the power circuit has conductors of adequate size (See Table 5).

5-9 LUBRICATION

Refer to Figure 11.

Proper lubrication is necessary for a long and relatively trouble-free hoist operation. Refer to the following and the RECOMMENDED LUBRICATION SCHEDULE for lubrication points, type of lubricant, and frequency of lubrication.

LOAD CHAIN

Clean the load chain with acid-free solvent and coat with SAE 90 Wt. gear oil. Wipe excess oil to prevent dripping. Never apply grease to the chain.

GEARING

The gear case of this hoist is filled at assembly with approximately 2 pints of SAE 90 Wt. EP gear oil. Check oil level by removing the

oil level fill plug from the side of the hoist. With the hoist hanging level, gear oil should be even with the hole. Change oil periodically depending on the severity of the application and the environmental conditions (at least every 200 hours of run time).

BEARINGS

All bearings except hook and idler sheave bearings are lubricated at the factory and should not require additional lubrication. Noisy or worn bearings should be replaced.

LIMIT SWITCH SHAFT

Remove any dirt accumulation and spray with a general purpose lubricant.

HOOK BEARING

Apply a few drops of SAE 30 Wt. gear or motor oil around the edge of the bearing.

IDLER SHEAVE BEARING (BUSHING)

Disassemble load block and apply a light coat of NLGI #2 grease, or equivalent, inside of bearing.

5-10 HOIST REPAIRS

1. For major repairs or when the hoist is to be sectioned in the suspension area, it will be necessary to move the hoist to a workbench or table.
2. For repairs which can be done by removing the electrical cover only, the hoist need not be moved. Lowering the hoist to a convenient working level is desirable.

NOTE: If you do not have an experienced mechanic to do your repair work, we recommend that you send your hoist to an approved service station for repairs. Use authorized repair parts only.

WARNING

Remove load and disconnect hoist from power supply before starting to do any repairs or to take any sections apart.

The following repair instructions will help you in understanding repair procedures, when related to the Replacement Parts List starting on page 21. For clarity these are broken down into areas.

ELECTRICAL PARTS AND BRAKE

1. Refer to Figures 15, 16 and 17. Remove the cover to access the controls. Single-phase models also have a starting switch and capacitor mounted on the panel as shown in Figure 16. The terminal blocks and end clamps snap off of the rails on the panel plate using a small screwdriver. DO NOT SLIDE THE END CLAMPS. The reversing contactor can be slid off the rail, but it must be snapped on. Where the contactor fits the rail, one side has springs or pads that apply pressure against the edge of the rail. By pressing against that side at the base of the contactor, you can snap the part on or off using a rotating action. Note the numbers that label the terminals on the contactor and orient the part as shown in Figures 9A-9D. Single-phase contactors have a small jumper that is not present on the 3-phase (note the 3 and 5 terminals on the reversing contactor in Figure 9A).
2. Remove the electrical panel by removing the stand-off screws (See Figures 16 & 17). The limit switch and brake are now accessible as shown in Figure 6.

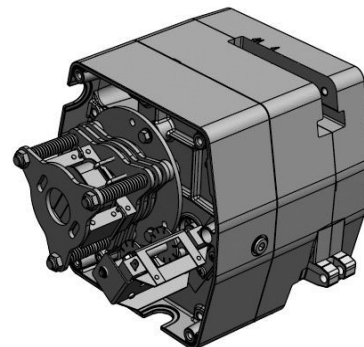

Figure 6 – Electrical Panel Removed

3. Remove the transformer bolted to the back of the panel plate if it requires replacement.
4. Refer to Figure 15 to disassemble the brake. See BRAKE ADJUSTMENT on page 9 to properly set the brake.
5. Refer to Figures 20 and 21 to disassemble the limit switch. See LIMIT SWITCH ADJUSTMENT on page 8 to properly set the upper and lower limits of travel.
6. Refer to Figures 18 and 19 for repairs on the pushbutton station. Also refer to the wiring diagram inside the electrical cover or Figures 9A, 9B, 9C and 9D for wiring instructions.

MOTOR

Refer to Figures 12, 13 and 14.

The hoist motor is located on the opposite end to from the electrical parts, but the two are tied together with electrical leads running through the housing.

1. If it is necessary to replace or repair the motor, DISCONNECT THE HOIST FROM THE POWER SUPPLY and remove the electrical cover.
2. Loosen the screw clamps on the terminal blocks and reversing contactor to disconnect the motor leads (See Figures 16 and 17).
3. Remove the four motor mounting bolts attaching the motor to the housing. It will come loose at the motor coupling.
4. Inspect the motor coupling, motor shaft and all the bearings. Replace as necessary.
5. Install new or repaired motor according to the wiring diagram located inside the electrical cover or Figures 9A, 9B, 9C and 9D.

GEARING

Refer to Figures 7, 12 and 22.

As disassembly is extensive for gearing, disconnect the hoist and move it to a workbench.

1. Remove the electrical cover.
2. Remove the electrical panel.
3. Remove the brake assembly and the limit switch assembly.
4. Remove the limit switch spring from output shaft bore.
5. Drain the oil from the transmission.
6. Remove the five screws that attach the transmission cover to the transmission housing and remove the transmission cover.

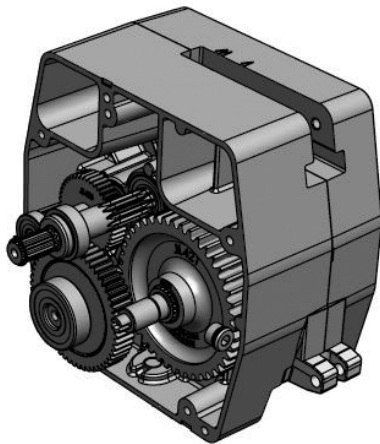

Figure 7 — Assembled Gearing

CAUTION

There are wires running through the hoist. Carefully ease the hoist sections apart. Do not jerk them apart.

7. Inspect gears for broken or severely worn teeth and inspect all bearings. Replace as necessary. The overload slip clutch is factory calibrated and must not be disassembled or readjusted.

CAUTION

Do not disassemble or readjust the clutch, or replace it with a clutch assembly from another hoist. Doing so will void the warranty and may create an unsafe condition. If replacement is needed due to wear or loss of adjustment, always use a new clutch assembly.

8. Reassemble in reverse order of disassembly, making sure that the gasket is in place and in good condition. Coat gasket with Permatex® or other gasket cement. Extreme care should be taken to avoid damage to oil seals.
9. Check all wire terminals to be sure that they are properly seated and in accordance with the correct wiring diagram. Before placing the hoist back into service, check the brake adjustment and limit switch settings.

CHAIN GUIDE AND LOAD SHEAVE

(Refer to Figures 12, 22 & 23)

The hoist sections must be separated at the top hook line in order to inspect the Load Sheave and Chain Guide.

1. Disconnect the Hoist and remove to a workbench.
2. Remove the Socket Head Cap Screw and Attachment Pin that hold in the Chain Stripper.
3. Remove the Chain Stripper.
4. Remove the 4 bolts that hold on the Motor.
5. Remove the Motor.
6. Remove the Spring Washer and Motor Coupling.
7. Remove the Hook Retaining Screw.
8. Remove the Hook Retainer.
9. Remove the Top Hook (Note the orientation of the hook for reassembly).
10. Remove the remaining 3 Screws that hold on the Trim Cover.
11. Remove the Trim Cover.
12. Remove the 5 Socket Head Cap Screws that hold the Sheave Housing to the Transmission Housing.
13. Gently pry apart the two housings using the slots provided, taking care not to damage the Gasket between the two housings.

While these housings are apart, check the following:

- Chain Stripper
- Chain Guide
- Chain
- Load Sheave
- Load Sheave Shaft
- Bearings
- Chain Support (on 2 ton models)

Replace worn or damaged parts as necessary including screws, lock washers, pins, etc. Care must be taken during reassembly to have the hook in the proper orientation (See SUSPENSION, page 11).

SUSPENSION

Periodic inspections of the top suspensions can be made without disassembly. For more extensive inspections the lug or top hook

may be removed as follows:

1. Disconnect the Hoist and remove it to a workbench.
2. Remove the Hook Retaining Screw.
3. Remove the Hook Retainer.
4. Remove the Hook (Note the orientation of the hook for reassembly).

Care must be taken during reassembly to have the hook in proper orientation. Refer to figures 8A, 8B & 8C for proper orientation

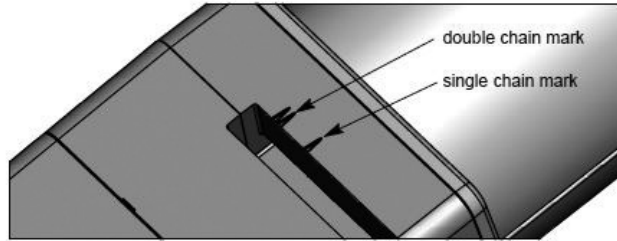

Figure 8A – Hook Orientation Marks

For Single Chain Hoist Installation, orient the centerline of the top hook with the single mark on the top of the sheave housing (Figure 8A). Hook installation should be as shown in Figure 8B.



Figure 8B - Single Chain Hook Orientation

For Double Chain Hoist Installations, orient the centerline of the top hook with the double marks on the top of the sheave housing (Figure 8A). Hook installation should be as shown in Figure 8C.



Figure 8C - Double Chain Hook Orientation

When reassembled, recheck the limit switch settings (See LIMIT SWITCH ADJUSTMENT, page 8).

5-11 POWER CORD PRECAUTIONS WITH 1-PHASE HOISTS

Electric hoists require a sufficient power supply. It is especially important with single-phase voltage to ensure that the conductors running to the hoist from the power source are adequate in size to handle the power requirements of the hoist. **Inadequate power cables and branch circuits will cause low voltage, high amperage, damage to the hoist, and potential fire hazards.**

Such problems can be minimized by using 230V power on 115/230V hoists. The following are recommendations for the conductor gage size depending on the length, horsepower, and voltage.

Table 5 - Recommended Conductor Sizes for 1-Phase Hoist

Hoist HP (fast/slow)	Voltage (1-Phase)	Maximum Length of Power Cord in Feet			
		14 AWG	12 AWG	10 AWG	8 AWG
1/4	115V	75	120	190	300
	230V	350	560	900	–
1/2	115V	40	60	100	150
	230V	200	330	250	810
1	115V	0	30	50	75
	230V	120	190	310	490

VI – TROUBLESHOOTING

Always disconnect unit from the power supply system before removing hoist covers or the back cover of control station

WARNING

Failure to follow proper lockout/tagout procedures may present the danger of electrical shock.

TO AVOID INJURY:
Disconnect power and lockout/tagout disconnecting means before removing cover or servicing this equipment

Problem	Probable Cause	Remedy
Hook fails to stop at end of travel	1. Limit switch not operating.	1. Check adjustment (See LIMIT SWITCH ADJUSTMENT, page 8). Check connections against wiring diagram. Tighten loose connections or replace.
	2. Brass limit switch nuts not moving on shaft.	2. Check for stripped threads or bent nut guide.
	3. Hoist reversing contactor malfunctioning.	3. Remove electrical cover and check reversing contactor.
Hoist does not respond to pushbutton	1. Power failure in supply lines.	1. Check circuit breakers, switches and connections in power supply lines.
	2. Wrong voltage or frequency.	2. Check voltage and frequency of power supply against the rating on the nameplate of the motor.
	3. Improper connections in hoist or pushbutton station.	3. Check all connections at line connectors and on terminal block. Check terminal block on dual voltage hoists for proper voltage connections.
	4. Brake does not release.	4. Check connections to the solenoid coil. Check for open or short circuit. Check for proper adjustment (See BRAKE ADJUSTMENT, page 9).
	5. Faulty hoist reversing contactor	5. Check coils for open or short circuit. Check all connections in control circuit. Check for burned contacts. Replace as needed.
Hook does not stop promptly	1. Hoist overloaded.	1. Reduce load to within rated capacity of hoist.
	2. Brake not holding.	2. Check brake adjustment (See BRAKE ADJUSTMENT, page 9). It may be necessary to replace discs.
Hook moves in wrong direction	1. Three phase reversal.	1. Reverse any two wires (except the green ground wire) at the power source (See INSTALLATION 3c, page 5).
	2. Improper connections.	2. Check all connections against wiring diagram.
Hoist hesitates to lift when energized	1. Hoist overloaded.	1. Reduce load within rated capacity of hoist.
	2. Motor brake requires adjustment.	2. Check motor brake adjustment (See BRAKE ADJUSTMENT, page 9)
	3. Worn overload limiting clutch.	3. Replace clutch.
	4. Low voltage.	4. Determine cause of low voltage and bring up to within plus or minus 10% of the voltage specified on the motor. Measure voltage at the hoist reversing contactor while lifting a load.
	5. Faulty SINPAC® starting switch or start capacitor (single phase hoist only).	5. Replace faulty component
Hook raises but will not lower	1. "DOWN" circuit open.	1. Check circuit for loose connections. Check "DOWN" limit switch for malfunction.
	2. Broken conductor in pushbutton cable.	2. Check each conductor in the cable. If one is broken, replace entire cable.
	3. Faulty hoist reversing contactor.	3. Check coils for open or short circuit. Check all connections in control circuit. Check for burned contacts. Replace as needed.
	4. Loose screw clamps.	4. Ensure that screw clamps are tightened on the terminal blocks and reversing contactor.
Hook lowers but will not raise	1. Hoist overloaded.	1. Reduce load to within rated capacity of hoist.
	2. Low voltage.	2. Determine cause of low voltage and bring up to within plus or minus 10% of the voltage specified on the motor. Measure voltage at the hoist reversing contactor while lifting a load.
	3. "UP" circuit open.	3. Check circuit for loose connections. Check "UP" limit switch for malfunction.
	4. Broken conductor in pushbutton cable.	4. Check each conductor in the cable. If one is broken, replace entire cable.
	5. Faulty hoist reversing contactor.	5. Check coils for open or short circuit, check all connections in control circuit. Check for burned contacts. Replace as needed.
	6. Faulty capacitor (single phase hoist only).	6. Check starting capacitor on motor. Replace if necessary.
	7. Worn overload limiting clutch.	7. Replace overload clutch assembly.
	8. Loose screw clamps.	8. Ensure that screw clamps are tightened on the terminal blocks and reversing contactor.

SECTION VI – TROUBLESHOOTING CONTINUED

Problem	Probable Cause	Remedy
Motor overheats	1. Excessive load.	1. Reduce load to within rated capacity of hoist.
	2. Low voltage.	2. Determine cause of low voltage and bring up to within plus or minus 10% of the voltage specified on the motor. Measure voltage at the hoist reversing contactor while lifting a load.
	3. Extreme external heating.	3. As the ambient temperature rises towards the 130°F limitation of the unit, frequency of the hoist operation must be limited to avoid overheating of the motor. See ADVERSE ENVIRONMENTAL CONDITIONS, page 4.
	4. Frequent starting or reversing.	4. Excessive inching, jogging or reversing should be avoided since this type of operation will drastically shorten the life of motor, contactor and brake.
	5. Brake dragging.	5. Check brake adjustment (See BRAKE ADJUSTMENT, page 9)
Lack of proper lifting speeds	1. Hoist overloaded.	1. Reduce load to within rated capacity of hoist.
	2. Brake dragging.	2. Check for proper brake adjustment or other defects.
	3. Low voltage.	3. Ensure that the voltage at the reversing contactor is within $\pm 10\%$ of the nominal voltage while lifting a load.
	4. Overload limiting clutch intermittently slipping.	4. Replace overload clutch assembly.
Motor brake noise or chatter (while starting hoist)	1. Brake needs adjustment.	1. See BRAKE ADJUSTMENT, page 9.
	2. Low voltage	2. Ensure that the voltage at the reversing contactor is within $\pm 10\%$ of the nominal voltage while lifting a load.
Motor brake “buzz” (anytime hoist is running)	1. Brake needs adjustment.	1. See BRAKE ADJUSTMENT, page 9.
	2. Broken shading coil on brake frame.	2. Replace shading coil or complete brake frame assembly.

SECTION VII – WIRING

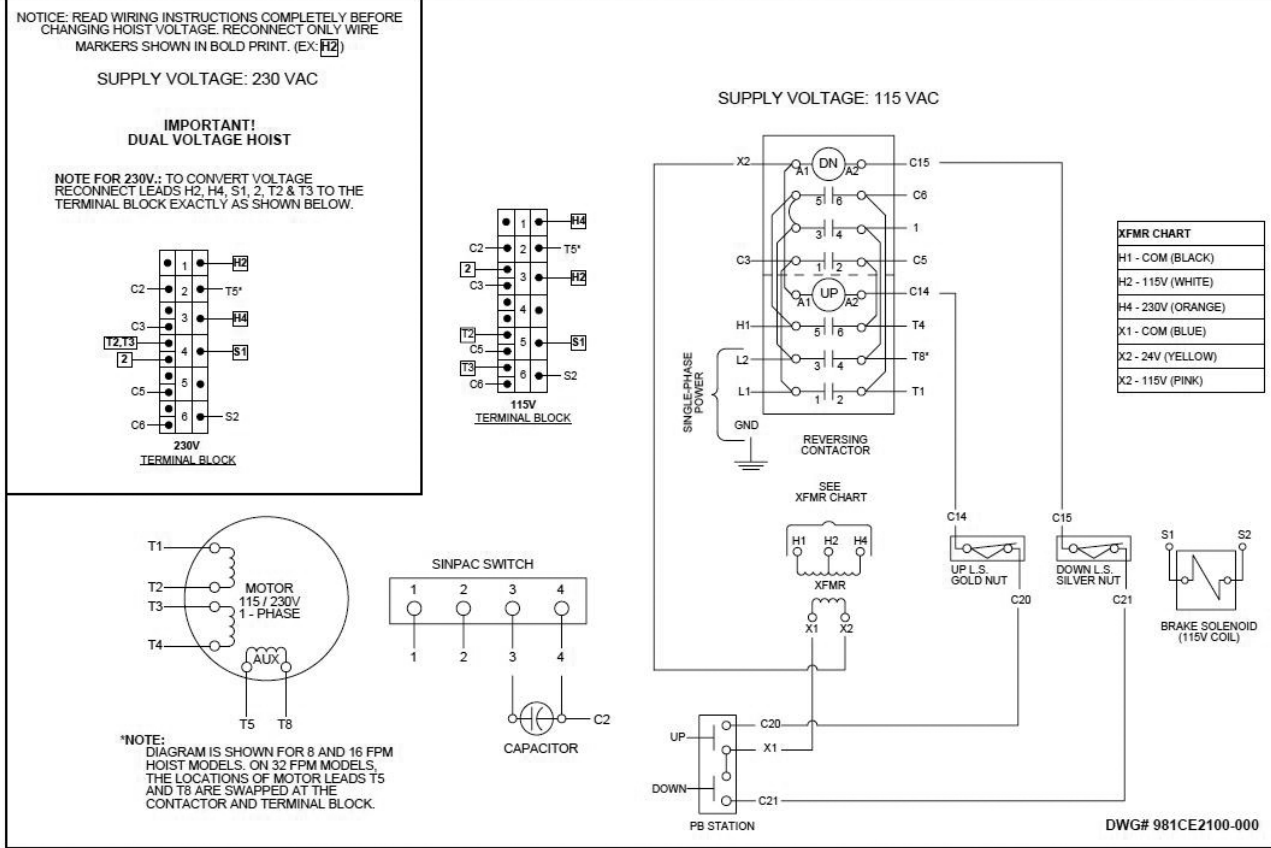

Figure 9A – Wiring Diagram for 115/230V - 1 Phase Models

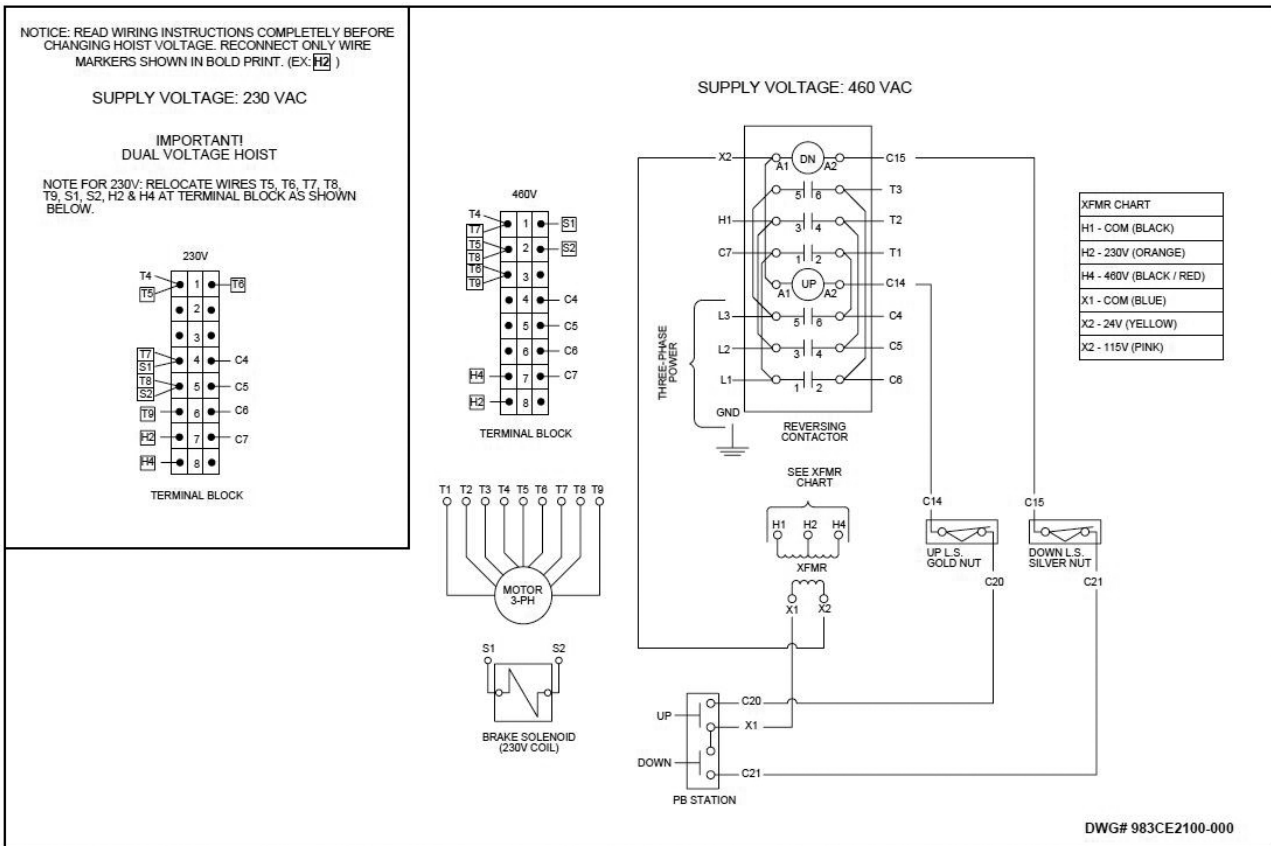

Figure 9B – Wiring Diagram for 1-Speed, 230/460V - 3 Phase Models

SECTION VII – WIRING CONTINUED

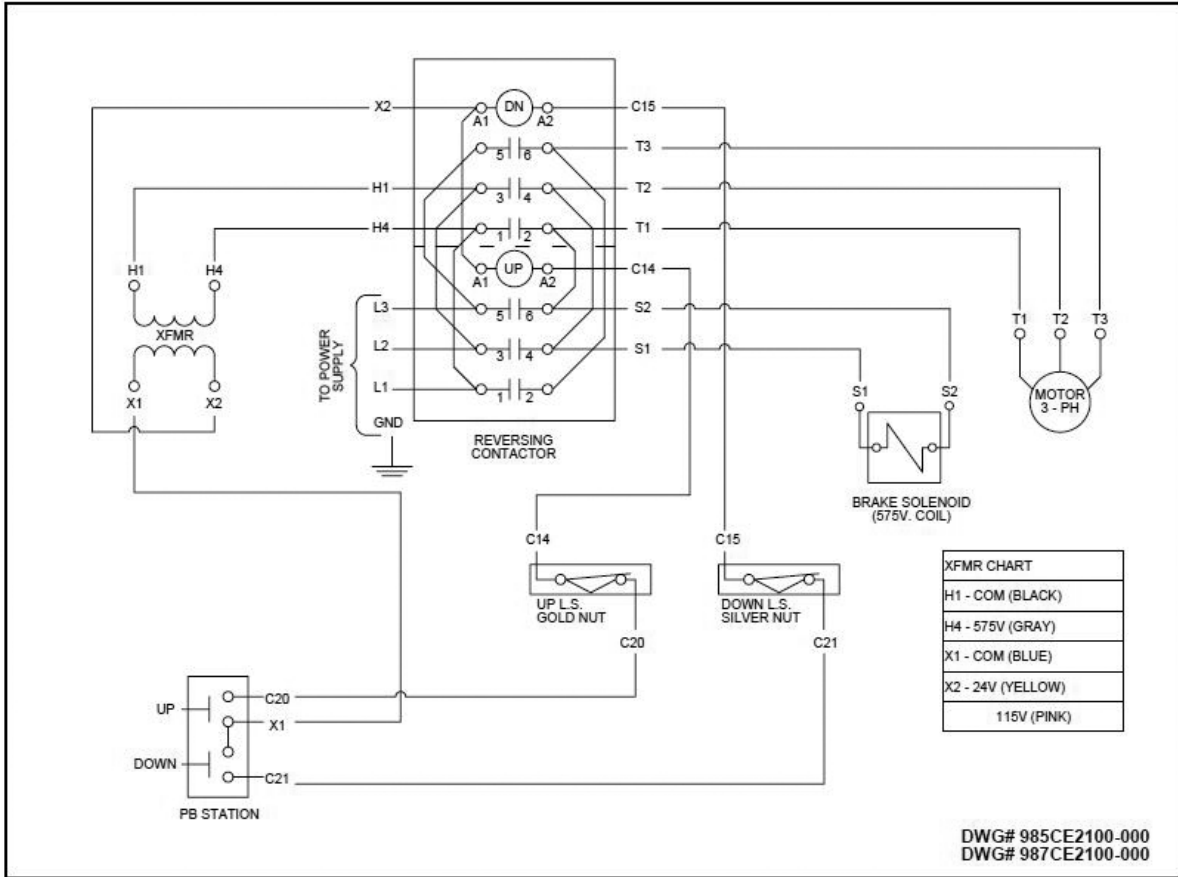

Figure 9C – Wiring Diagram for 1-Speed, 208V and 575V - 3 Phase Models

* Factory supplied diagrams will be numbered beginning with 985 for 575V and 987 for 208V.

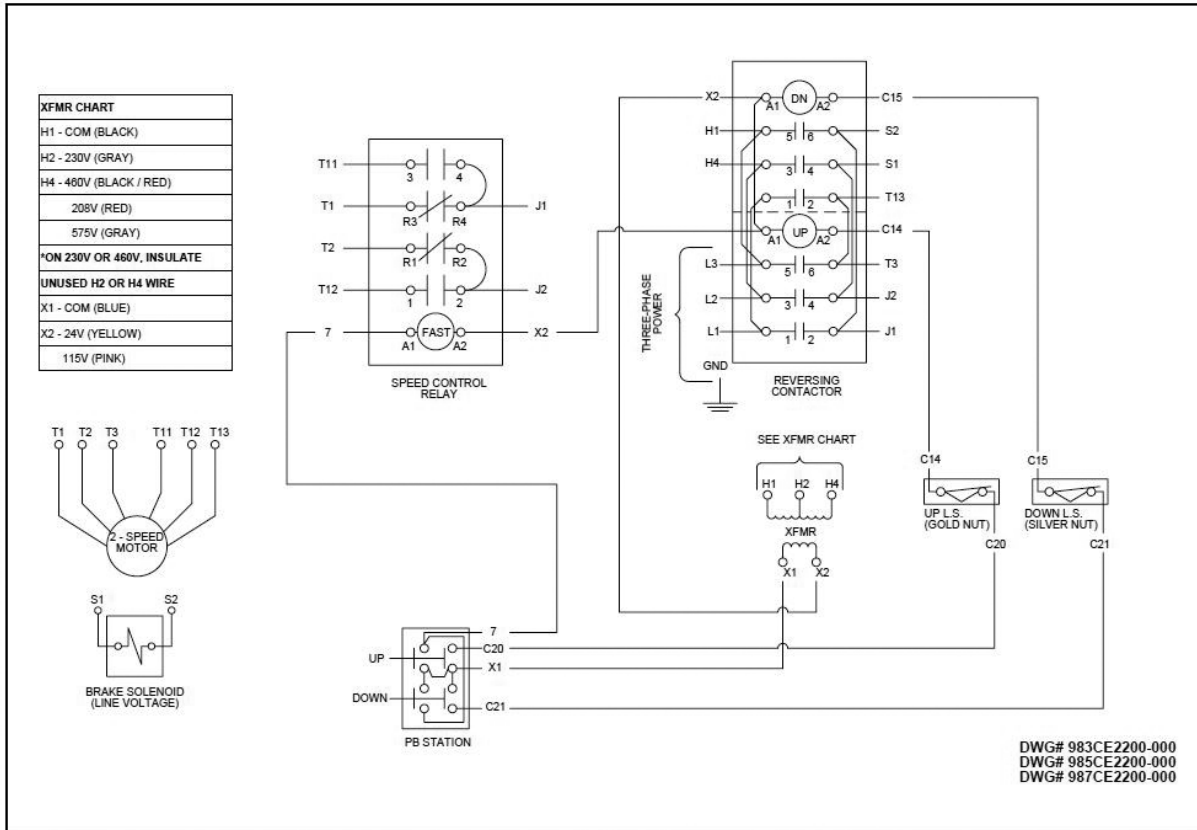

Figure 9D – Wiring Diagram for 2-Speed, 3 Phase Models

* Factory supplied diagrams will be numbered beginning with 983 for 230 or 460V, 985 for 575V and 987 for 208V.

SECTION VIII – INSPECTION

INSPECTION

To maintain continuous and satisfactory operation, a regular inspection procedure must be initiated to replace worn or damaged parts before they become unsafe. Inspection intervals must be determined by the individual application and are based on the type of service to which the hoist will be subjected. The type of service to which the hoist is subjected can be classified as “Normal”, “Heavy”, or “Severe”. Normal Service: Involves operation with randomly distributed loads within the rated load limit, or uniform loads less than 65 percent of rated load for not more than 25 percent of the time.

HEAVY SERVICE:

Involves operating the hoist within the rated load limit which exceeds normal service.

SEVERE SERVICE:

Normal or heavy service with abnormal operating conditions or constant exposure to the elements of nature. Two classes of inspection - frequent and periodic - must be performed.

FREQUENT INSPECTIONS:

These inspections are visual examinations by the operator or other designated personnel. Records of such inspections are not required. The frequent inspections are to be performed monthly for normal service, weekly to monthly for heavy service, and daily to weekly for severe service, and they should include those items listed in Table 7.

PERIODIC INSPECTIONS:

These inspections are visual inspections of external conditions by an appointed person. Records of periodic inspections are to be kept for continuing evaluation of the condition of the hoist. Periodic inspections are to be performed yearly for normal service, semi-annually for heavy service and quarterly for severe service, and they are to include those items listed in Table 8.

CAUTION: Any deficiencies found during inspections are to be corrected before the hoist is returned to service. Also, the external conditions may show the need for disassembly to permit a more detailed inspection, which, in turn, may require the use of nondestructive type testing

PREVENTATIVE MAINTENANCE

In addition to the above inspection procedure, a preventive maintenance program should be established to prolong the useful life of the hoist and maintain its reliability and continued safe use. The program should include the periodic and frequent inspections with particular attention being paid to the lubrication of the various components using the recommended lubricants (see Figure 11).

SECTION VII – INSPECTION CONTINUED

INSPECTION AND MAINTENANCE CHECK LIST ELECTRIC POWERED OVERHEAD CHAIN HOIST

Type of Hoist _____ Capacity (Tons) _____
 Location _____ Original Installation Date _____
 Manufacturer _____ Manufacturer's Serial No. _____

Item	Frequency of Inspection			Possible Deficiencies	Ok	Action Required
	Frequent		Periodic			
	Daily	Monthly	Every 3 Months to Annually as defined per ASME B30.16			
Operating Controls	*	*	*	Any deficiency causing improper operation		
Limit Switches	*	*	*	Any deficiency causing improper operation Pitting or deterioration		
Brake Mechanism	*	*	*	1. Slippage or excessive drift 2. Glazing, contamination or excessive wear		
Hooks	*	*	*	Excessive throat opening 15% bent or twisted more than 10 degrees, damaged hook latch, wear, chemical damage, worn hook bearing. Cracks (use dye penetrant, magnetic or other suitable detection method)		
Suspension Lug (if used)*	*	*	*	Cracks, excessive wear or other damage which may impair the strength of the lug. Cracks (use dye penetrant, magnetic particle or other suitable detection method)		
Chain	*	*	*	Inadequate lubrication, excessive wear or stretch, cracked, damaged or twisted links, corrosion or foreign substance		
Hook and Suspension Lug Connections			*	Cracks, bending, stripped threads		
Pins, Bearings, Bushings Shafts, Couplings			*	Excessive wear, corrosion, cracks, distortion		
Nuts, Bolts, Rivets			*	Looseness, stripped and damaged threads, corrosion		
Sheaves			*	Distortion, cracks, and excessive wear. Build-up of foreign substances		
Housings, Load Block			*	Cracks, distortion. Excessive wear, internal build-up of foreign substances		
Wiring and Terminals			*	Fraying, defective insulation		
Hoist Reversing Contactor, other Electrical Apparatus			*	Loose connections, burned or pitted contacts		
Supporting Structure and Trolley (if used)			*	Damage or wear which restricts ability to support imposed loads		
Nameplates, Decals, Warning Labels			*	Missing, damaged or illegible		
Transmission Lubricant			*	Low level requires changing		
NOTE: Refer to Maintenance and Inspection Sections of this manual for further details.						

Figure 10A – Recommended Inspection and Maintenance Check List

NOTE: This inspection and maintenance check list is in accordance with our interpretation of the requirements of the Safety Standard for Overhead Hoists ASME B30.16. It is, however, the ultimate responsibility of the employer/user to interpret and adhere to the applicable requirements of this safety standard.

SECTION VII – INSPECTION CONTINUED

INSPECTOR'S REPORT			
ITEM	REMARKS (LIST DEFICIENCIES AND RECOMMENDED ACTION)		
Inspector's Signature	Date Inspected	Approved By	Date

Figure 10B - Recommended Inspector's Report

RECOMMENDED LUBRICATION SCHEDULE* COFFING ELECTRIC POWERED CHAIN HOIST					
Page and Reference No	Component	Type of Lubricant	Type of Service and Frequency of Lubrication.		
			HEAVY	NORMAL	INFREQUENT
Pages 30 & 31 Ref. No. 9	Load Chain	SAE 90 gear oil	Daily	Weekly	Monthly
Pages 28 & 29	Gearing	SAE 90 WT extreme pressure (EP) gear oil	At periodic inspection (see Figure 10A)		
Pages 26 & 27 Ref. Nos. 9 & 7	Limit Switch Shaft	Multi-purpose oil or general purpose spray	Monthly	Yearly	Yearly
Pages 30 & 31 Ref. No. 19 & 31	Load Hook Bearing	SAE 30 gear oil or motor oil	Weekly	Monthly	Yearly
Pages 30 & 3 Ref. No. 28	Idler Sheave Bearing (Bushing) Assembly	Multi-purpose lithium base bearing grease - NLGI #2	At periodic inspection (see Figure 10A)		

NOTE: All bearings except hook and idler sheave bearings are prelubricated and sealed.

* This lubrication schedule is based on a hoist operating in normal environment conditions. Hoists operating in adverse atmospheres containing excessive heat, corrosive fumes or vapors, abrasive dust, etc., should be lubricated more frequently.

Figure 11 — Recommended Lubrication Schedule

SECTION IX – REPAIR PARTS LIST

WARNING

Using “Commercial” or other manufacturer’s parts to repair the Coffing Hoists may cause load loss.

TO AVOID INJURY:

Use only Coffing supplied replacement parts. Parts may look alike but Coffing parts are made of specific materials or processed to achieve specific properties



ORDERING INSTRUCTIONS

The following information must accompany all correspondence orders for replacement parts:

1. Hoist Model Number from identification plate.
2. Serial number of the hoist stamped below identification plate.
3. Voltage, phase, hertz from the identification plate
4. Length of lift.
5. Part number of part from parts list.
6. Number of parts required.
7. Part name from parts list.

NOTE: When ordering replacement parts, it is recommended that consideration be given to the need for also ordering such items as gaskets, fasteners, insulators, etc. These items may be damaged or lost during disassembly or just unfit for future use because of deterioration from age or service.

FIGURE 12 – BASIC HOIST

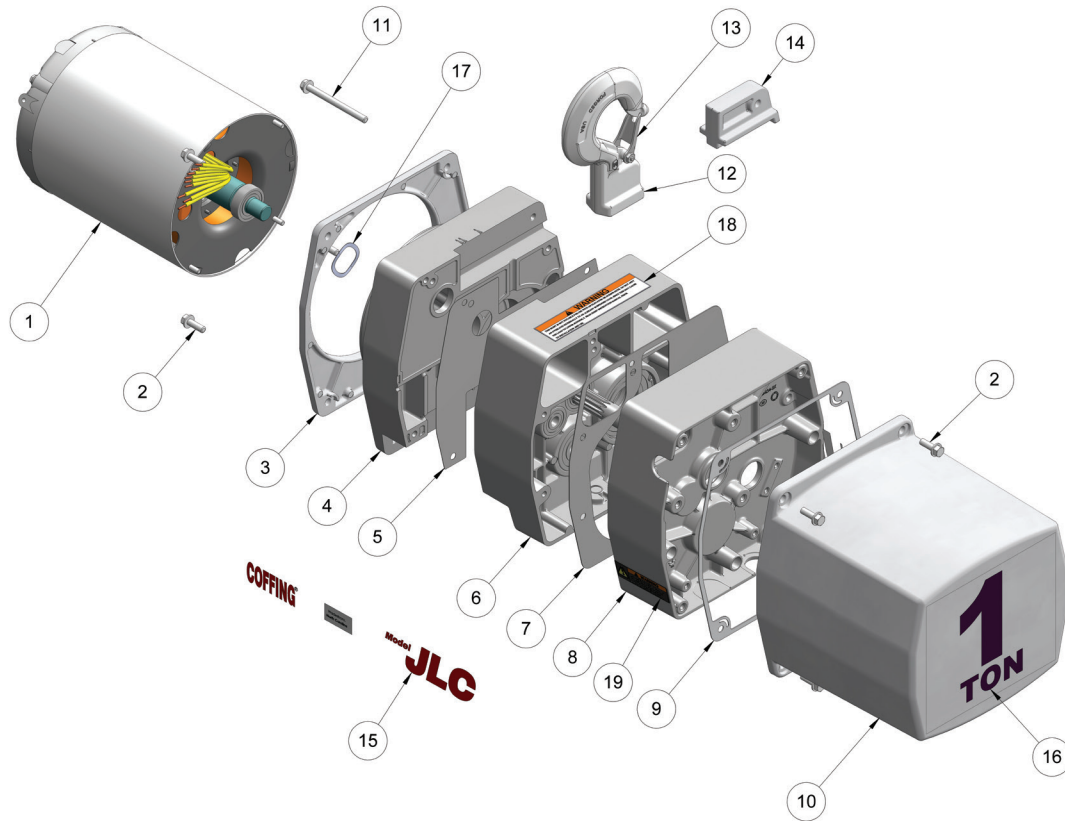

Ref. no	Description	Part No.	Qty
1	Motor (See Figures 13 & 14)	-	1
2	Cover Screw	H2976P	1
3	Trim Cover	JM37	1
4	Sheave Housing	JM33-1	
5	Sheave Housing Gasket	JM560-3	1
6	Transmission Housing	JM35-1	1
7	Transmission Housing Gasket	JM560-2	1
8	Transmission Cover	JM34-2	1
9	Electrical Cover Gasket	JM563	1
10	Electrical Cover	JM36	1
11	Hook Retainer Screw	H2709P	1
12	Top Hook Assembly with Latch Rigid Hook (Std)	3M405A01S	1
12	Top Hook Assembly with Latch Swivel Hook (optional)	51JM1	1
13	Latch Kit Assembly	4X1305	2
14	Hook Retainer	JM285	1

Ref. no	Description	Part No.	Qty
15	JLC & Coffing Decal (Left Hand)	JLC677-2L	1
15	JLC & Coffing Decal (Right Hand)	JLC677-2R	1
16	Capacity Decal 1/8 ton	JM675K01	1
16	Capacity Decal 1/4 ton	JM675K02	1
16	Capacity Decal 1/2 ton	JM675K05	1
16	Capacity Decal 1 ton	JM675K10	1
16	Capacity Decal 2 ton	JM675K20	1
17	Spring Washer	360J1	1
Not Shown	*JLCET Trolley (Lug Mounted) - 1 Ton & Under	09295	1
Not Shown	*JLCET Trolley (Lug Mounted) 2 Ton	09296	1
Not Shown	Suspension Lug Cross Mounted	JM50C	1
Not Shown	Suspension Lug Parallel Mounted	50JM1	1
18	Elevator Warning Label	JL687	2
19	Electrical Warning Label	24842	1

(*)Suspension lug is an option for JLC Models and standard for JLCET Models.

FIGURE 13 – HOIST MOTOR, 115/230V – 1 PHASE

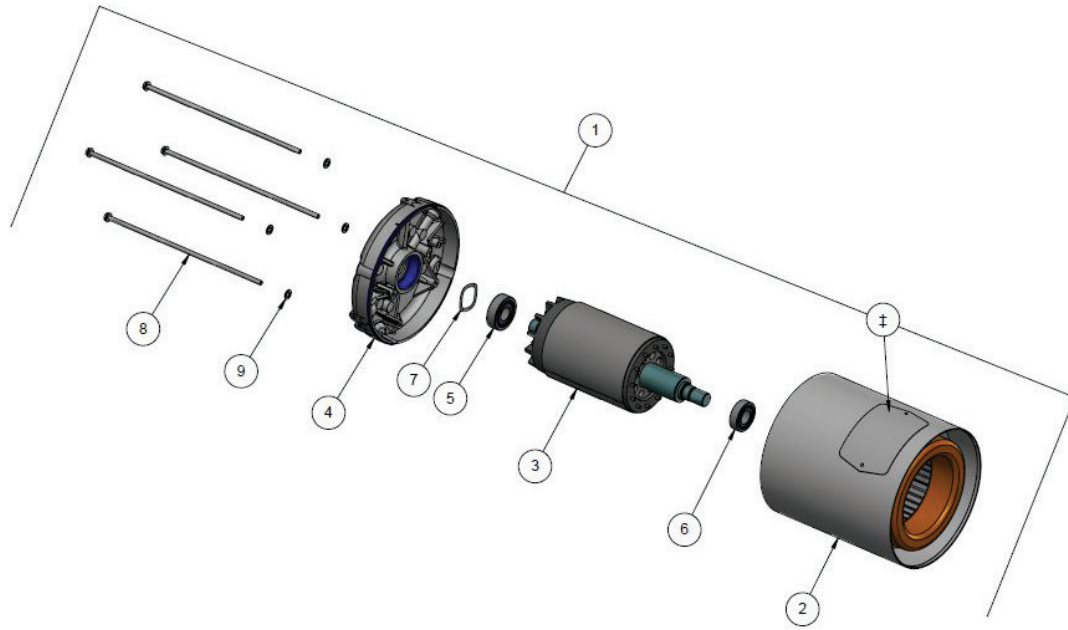

(‡) Refer to the motor nameplate for part number, voltage, full load amperage, horsepower, and other motor information.

Parts List for Hoist Motor, 115/230V - 1 phase

Ref. no	Description	Part No.	Qty
1	Hoist Motor - 1/2 hp, 115/230V-1Ph	861JR12	1
1	Hoist Motor - 1 hp, 115/230V-1Ph	861JR14	1
2	Stator Assembly	*	1
3	Rotor Assembly	*	1
4	End Shield	*	1
5	Rear Bearing	500K3	1
6	Front Bearing	*	1
7	Shim Washer	JL4301-01	1
8	Thru Bolt	HA3100A56	4
9	#10 Spring Lockwasher	H4082P	4

*Not available as an individual part.

FIGURE 14 – HOIST MOTOR – 3 PHASE

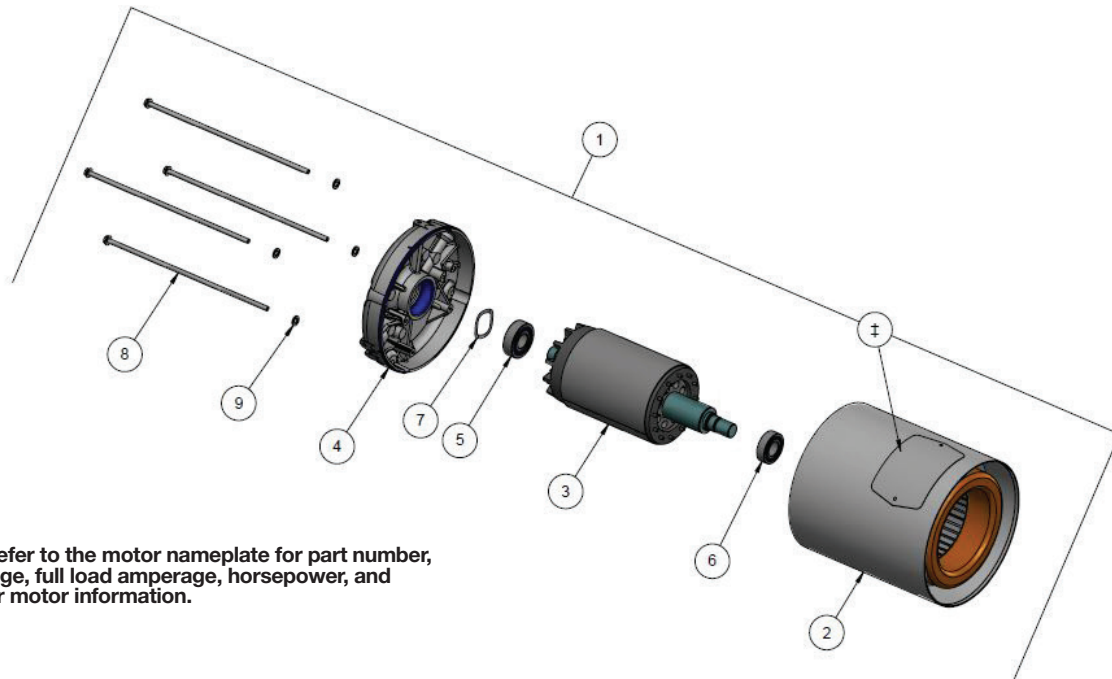

(‡) Refer to the motor nameplate for part number, voltage, full load amperage, horsepower, and other motor information.

Parts List for Hoist Motor, 3 Phase

Ref. no	Description	Part No.	Qty
1	Hoist Motor (1-Speed)	-	
	1/4 hp, 230/460V-3Ph-60Hz	863JR1	1
	1/2 hp, 230/460V-3Ph-60Hz	863JR2	1
	1 hp, 230/460V-3Ph-60Hz	863JR4	1
	1/4 hp, 575V-3Ph-60Hz	863JR5	1
	1/2 hp, 575V-3Ph-60Hz	863JR6	1
	1 hp, 575V-3Ph-60Hz	863JR8	1
	1/4 hp, 208V-3Ph-60Hz	863JR9	1
	1/2 hp, 208V-3Ph-60Hz	863JR10	1
	1 hp, 208V-3Ph-60Hz	863JR12	1
	Hoist Motor (2-Speed)		
	1/4 hp, 230V-3Ph-60Hz	873JR1	1
	1/2 hp, 230V-3Ph-60Hz	873JR2	1
	1 hp, 230V-3Ph-60Hz	873JR4	1
	1/4 hp, 460V-3Ph-60Hz	873JR5	1

Ref. no	Description	Part No.	Qty
	1/2 hp, 460V-3Ph-60Hz	873JR6	1
	1 hp, 460V-3Ph-60Hz	873JR8	1
	1/4 hp, 575V-3Ph-60Hz	873JR9	1
	1/2 hp, 575V-3Ph-60Hz	873JR10	1
	1 hp, 575V-3Ph-60Hz	873JR12	1
	1/4 hp, 208V-3Ph-60Hz	873JR13	1
	1/2 hp, 208V-3Ph-60Hz	873JR14	1
	1 hp, 208V-3Ph-60Hz	873JR16	1
2	Stator Assembly	*	1
3	Rotor Assembly	*	1
4	End Shield	*	1
5	Rear Bearing	500K3	1
6	Front Bearing	*	1
7	Shim Washer	JL4301-01	1
8	Thru Bolt (1-Speed)	HA3100A56	4
	Thru Bolt (2-Speed)	HA3100A71	4
9	#10 Spring Lockwasher	H4082P	4

* Not available as an individual part.

FIGURE 15 — BRAKE & SOLENOID PARTS

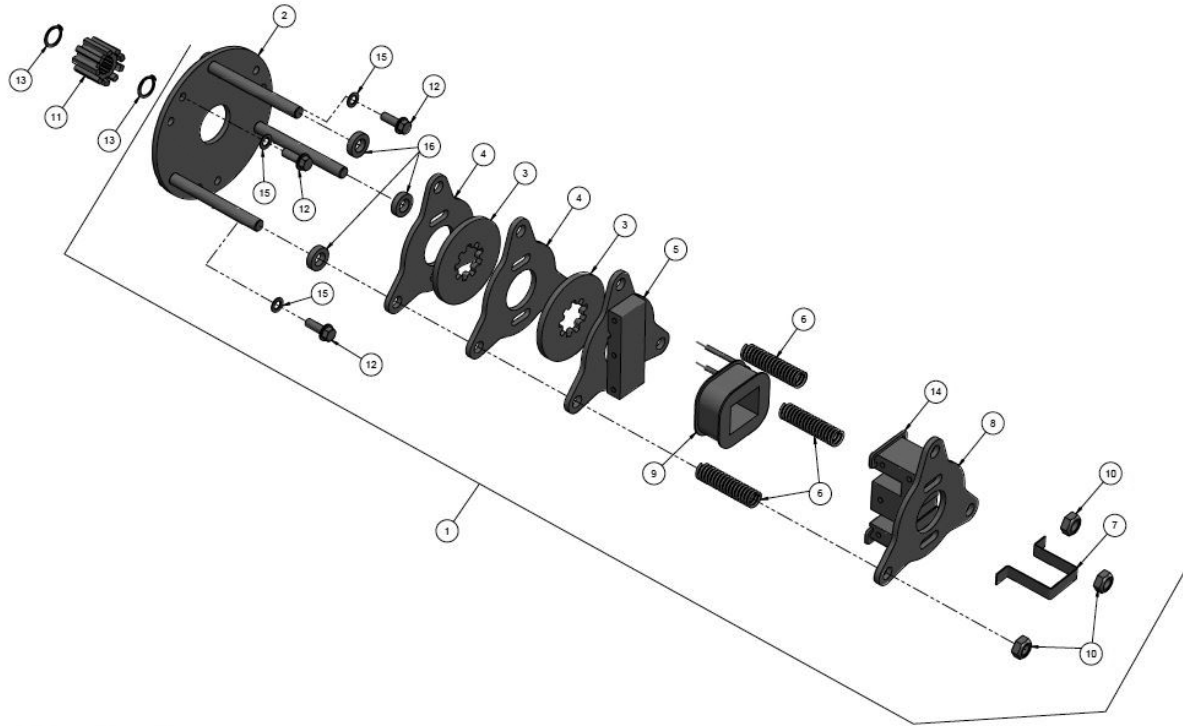

NOTE: Refer to wiring diagram inside electrical cover of hoist or Figures 9A, 9B, 9C or 9D, when connecting any wires.

Parts List for Brake & Solenoid Parts

Ref. no	Description	Part No.	Qty
1	Disc Brake Assembly*	—	
	1 hp, 115 Volt	854JM1	1
	1/4 & 1/2 hp, 115 Volt	854JM12	1
	1 hp, 230 Volt	854JM2	1
	1/4 & 1/2 hp, 230 Volt	854JM22	1
	1 hp, 460 Volt	854JM3	1
	1/4 & 1/2 hp, 460 Volt	854JM32	1
	1 hp, 575 Volt	854JM4	1
	1/4 & 1/2 hp, 575 Volt	854JM42	1
	1 hp, 208 Volt	854JM5	1
	1/4 & 1/2 hp, 208 Volt	854JM52	1
2	Plate & Stud Assembly	859JG1	1
3	Brake Disc		
	1/4 & 1/2 hp	581J1A	2
	1 hp	581J1A	3
4	Brake Plate	JF291	2
5	Plate & Armature Assembly	JF858	1
6	Spring	344J6	3

Ref. no	Description	Part No.	Qty
7	Retainer	JF710	1
8	Plate & Frame Assembly	JF857	1
9	Brake Coil*		
	115V	853JL1	1
	230V	853JL2	1
	460V	853JL3	1
	575V	853JL4	1
	208V	853JL5	1
10	Locknut	H3978	3
11	Brake Hub Adapter	JM142	1
12	Screw	H2976P	3
13	Retaining Ring	H5501	2
14	Shading Coil	860J1	2
NOT SHOWN	Shading Coil Adhesive	H7812	1
15	Lockwasher	H4134	3
16	Spacer for 1/4 & 1/2 hp	141J2	3
NOT SHOWN	Warning Decal	676J1	1

* Dual Voltage 115/230V hoist models use 115V Brake Assembly and Coil.

* Dual Voltage 230/460V hoist models use 230V Brake Assembly and Coil.

FIGURE 16 — ELECTRICAL PARTS — 1-SPEED MODELS

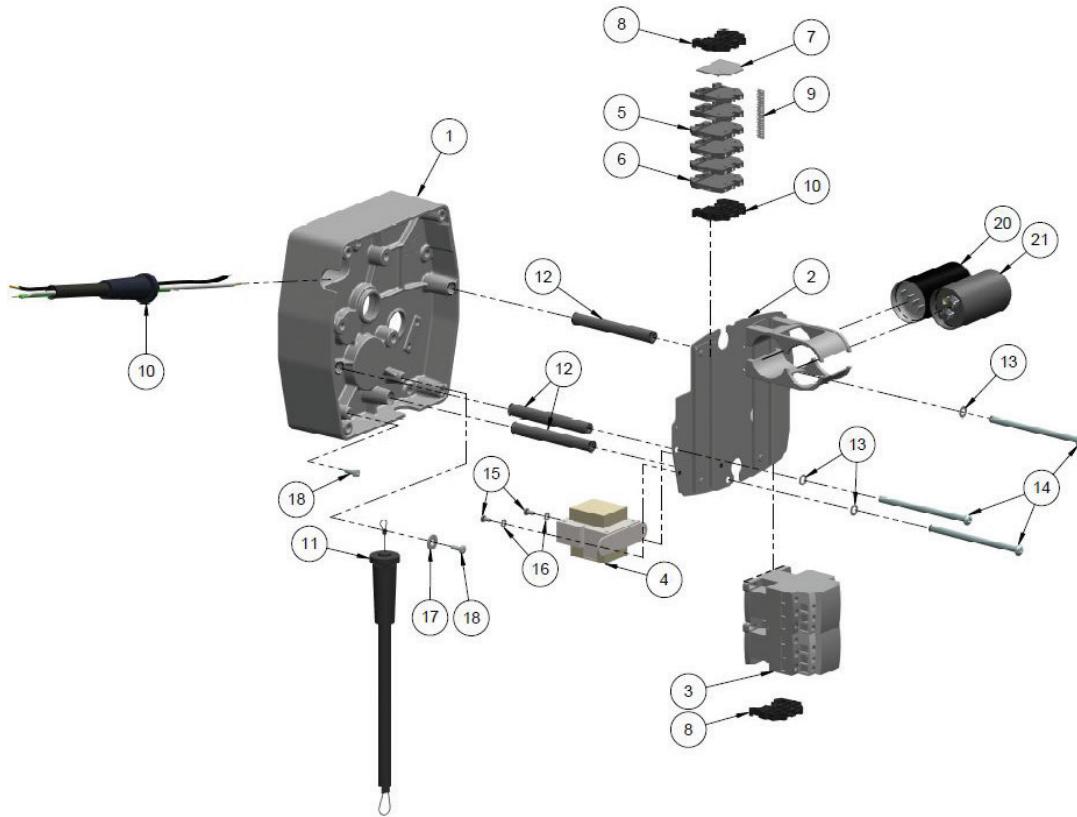

Parts List for Electrical Parts, 1-Speed Models

Ref. no	Description	Part No.	Qty
1	Transmission Cover	JM34-2	1
2	Panel Plate	257JM200	1
3	Reversing Contactor*		
	1/2 hp & under:		
	24V Coil	28860	1
	115V Coil	24799	1
	1 hp, 1-Phase:		
	24V Coil	24791	1
	115V Coil	28905	1
	1 hp, 3-Phase:		
	24V Coil	25943	1
	115V Coil	24729	1
4	Transformer*		
	Pri.: 115/230V, Sec.: 24V	821J412	1
	Pri.: 115/230V, Sec.: 115V	821J411	1
	Pri.: 230/460V, Sec.: 24V	821J432	1
	Pri.: 230/460V, Sec.: 115V	821J431	1
	Pri.: 575V, Sec.: 24V	821J452	1
	Pri.: 575V, Sec.: 115V	821J451	1
	Pri.: 208V, Sec.: 24V	821J472	1
	Pri.: 208V, Sec.: 115V	821J471	1
5	Terminal Block		
	115/230V	909J10	2

Ref. no	Description	Part No.	Qty
	230/460V	909J10	8
6	Terminal Block 115/230V	909J14	4
7	End Plate		
	115/230V	909J15	1
	230/460V	909J12	1
8	End Clamp		
	115/230V & 230/460V	909J13	3
	Single Voltage Models	909J13	1
9	Marking Strip	909J11	1
10	15 ft Power Cord Assembly		
	115/230V, 1/2 hp (3 cond.)	951JL1	1
	115/230V, 1 hp (3 cond.)	952JL1	1
	3-Phase (4 cond.)	953JL1	1
11	PB & Cable Assy (See Figures 18 & 19)	—	1
12	Panel Standoff Spacer	200J4	3
13	1/4" Internal-tooth Lockwasher	H4134	3
14	1/4-20UNC X 4" Screw	H1027P	3
15	8-32UNC X 5/16" Screw	H2751	2
16	#8 External-tooth Lockwasher	H4158	2
17	1/4" Flatwasher	H4002P	1
18	10-24UNC X 1/2" Screw	H2970	2
19†	Can Mounting Bracket	JM811	2
20†	SINPAC® Starting Switch	839J3	1
21†	Capacitor	JL810-4	1

*Coil voltage of the contactor and the secondary voltage of the transformer are the same. This is referred to as the control voltage. Standard units are supplied with 24V Control.
 (†) Single phase units only.

FIGURE 17 — ELECTRICAL PARTS — 2-SPEED MODELS

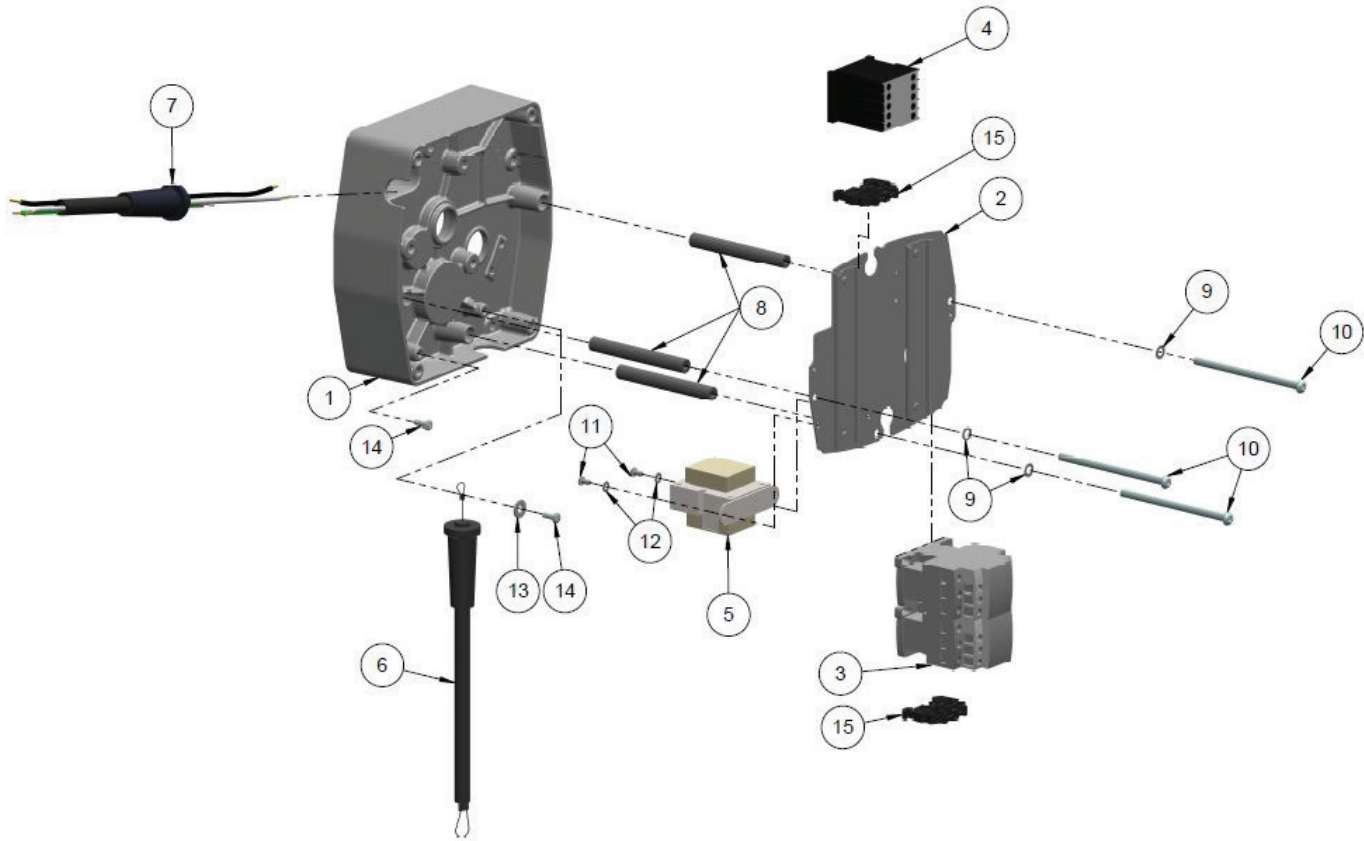

Parts List for Electrical Parts, 2-Speed Models

Ref. no	Description	Part No.	Qty
1	Transmission Cover	JM34-2	1
2	Panel Plate	257JM200	1
3	Reversing Contactor*		
	1/2 hp & under:		
	24V Coil	28860	1
	115V Coil	24799	1
	1 hp, 3-Phase:		
	24V Coil	25943	1
	115V Coil	24729	1
4	Speed Control Relay*		
	1/2 hp, 24V Coil	28878	1
	1/2 hp, 115V Coil	28870	1
	1 hp, 24V Coil	28885	1
	1 hp, 115V Coil	28879	1
5	Transformer*		
	Pri.: 230/460V, Sec.: 24V	821J432	1

Ref. no	Description	Part No.	Qty
	Pri.: 230/460V, Sec.: 115V	821J431	1
	Pri.: 575V, Sec.: 24V	821J452	1
	Pri.: 575V, Sec.: 115V	821J451	1
	Pri.: 208V, Sec.: 24V	821J472	1
	Pri.: 208V, Sec.: 115V	821J471	1
6	15 ft Power Cord Assembly	953JL1	1
7	PB & Cable Assy (See Figures 18 & 19)	—	1
8	Panel Standoff Spacer	200J4	3
9	1/4" Internal-tooth Lockwasher	H4134	3
10	1/4-20UNC X 4" Screw	H1027P	3
11	8-32UNC X 5/16" Screw	H2751	2
12	#8 External-tooth Lockwasher	H4158	2
13	1/4" Flatwasher	H4002P	1
14	10-24UNC X 1/2" Screw	H2970	2
15	End Clamp	909J13	2

*The coil voltage of the contactors and secondary voltage of the transformer are the same. This is referred to as the control voltage. Standard units are supplied with 24V Control..

FIGURE 18 — 1-SPEED PUSHBUTTON STATION

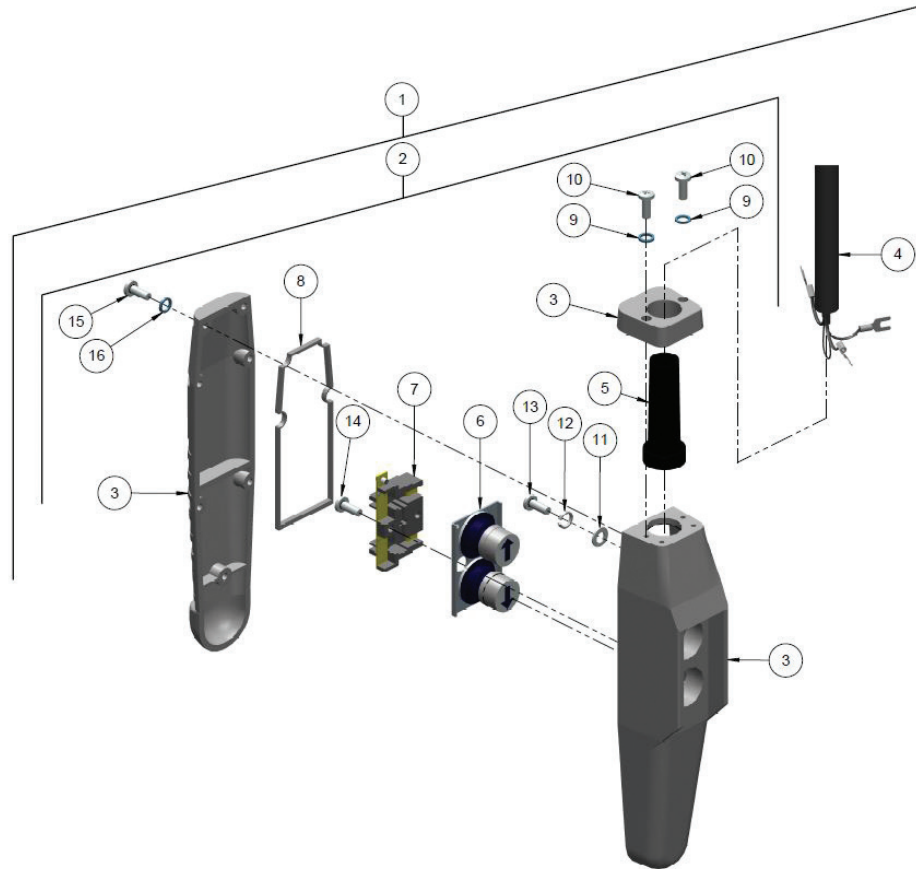

Parts List for Pushbutton, 1-Speed

Ref. no	Description	Part No.	Qty
1	Pushbutton Station and Control Cable Assembly		
	6 ft Cable Length	PB2100-6	1
	11 ft Cable Length	PB2100-11	1
	16 ft Cable Length	PB2100-16	1
2	Pushbutton Station Assembly (2-Button, 1-Speed)	36900R	1
3	Enclosure	36998R	1
4	Control Cable Assembly		
	6 ft Cable Length	PBC2100-6	1
	11 ft Cable Length	PBC2100-11	1
	16 ft Cable Length	PBC2100-16	1
	Special Drop	PBC2100-#	1
5	Grommet	36989	1
6	Button Assembly	-	-
7	Contact Assembly (includes items 6 & 7)	36987	1
8	Gasket	36986	1
*	Hardware Kit (includes items 9 thru 16)	36939	1
Not shown	Warning Tag	687K3W	1

(#) Length of Cable in Feet (pushbutton drop).

FIGURE 19 — 2-SPEED PUSHBUTTON STATION

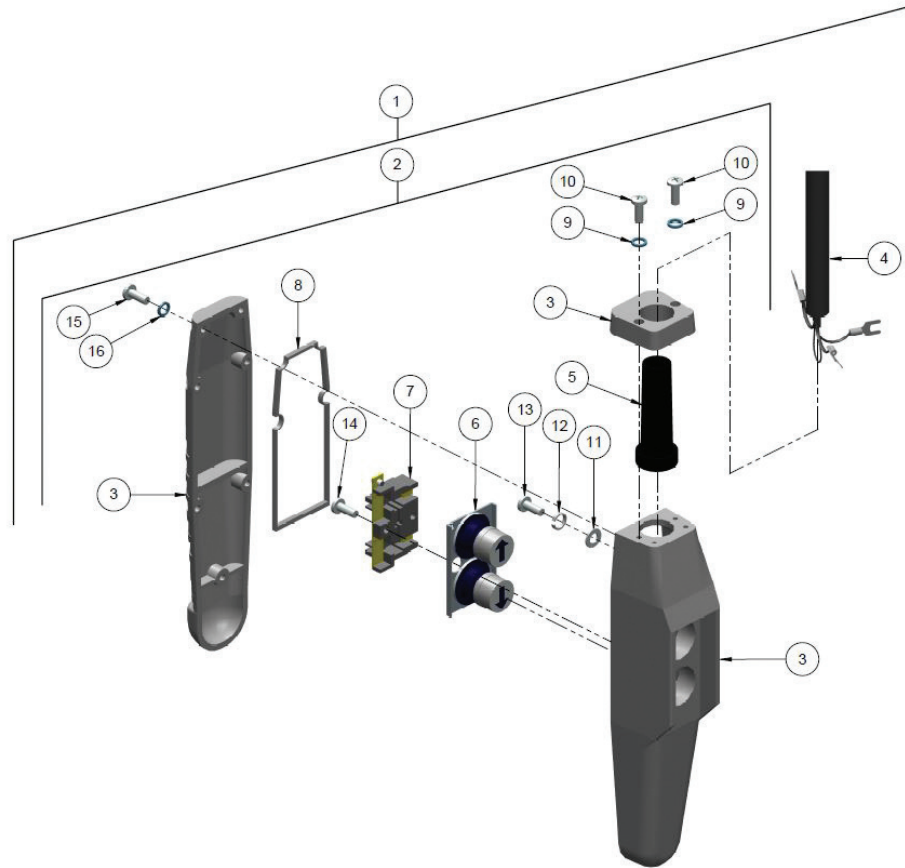

Parts List for Pushbutton, 2-Speed

Ref. no	Description	Part No.	Qty
1	Pushbutton Station and Control Cable Assembly		
	6 ft Cable Length	PB2200-6	1
	11 ft Cable Length	PB2200-11	1
	16 ft Cable Length	PB2200-16	1
2	Pushbutton Station Assembly (2-Button, 2-Speed)	36800R	1
3	Enclosure	36998R	1
4	Control Cable Assembly		
	6 ft Cable Length	PBC2200-6	1
	11 ft Cable Length	PBC2200-11	1
	16 ft Cable Length	PBC2200-16	1
	Special Drop	PBC2200-#	1
5	Grommet	36866	1
6	Button Assembly	-	-
7	Contact Assembly (includes items 6 & 7)	70964	1
8	Gasket	36986	1
*	Hardware Kit (includes items 9 thru 16) Warning Tag	36939	1
Not shown	Warning Tag	687K3W	1

(#) Length of Cable in Feet (pushbutton drop).

FIGURE 20 - COFFING ROCKET UNIVERSAL PENDANT CONTROL

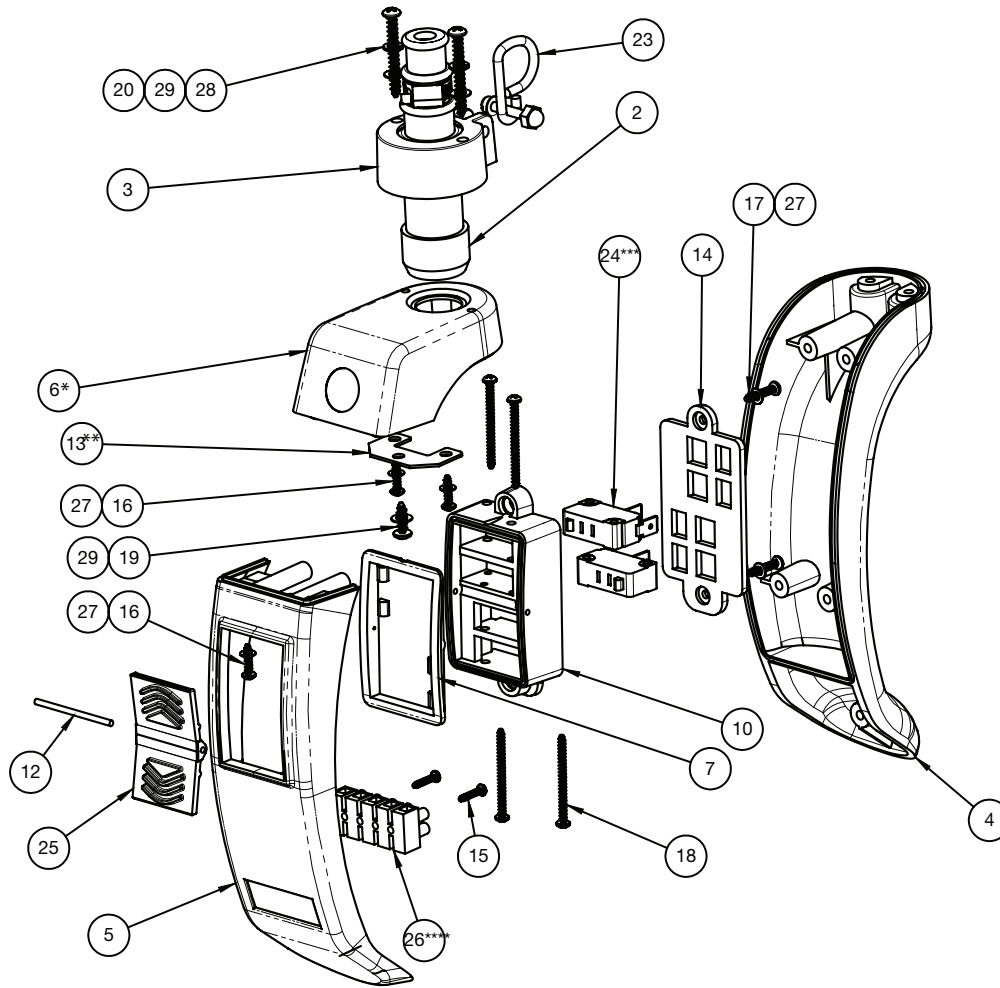

Part No.	Description
ECUR-1S	Rocket Pendant Control - Single-Speed, No E-stop
ECUR-2S	Rocket Pendant Control - 2-Speed, No E-stop
ECUR-1S-25P	25 PACK: Rocket Pendant Control - Single-Speed, No E-stop
ECUR-2S-25P	25 PACK: Rocket Pendant Control - 2-Speed, No E-stop

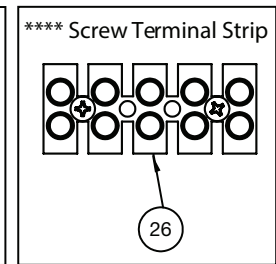
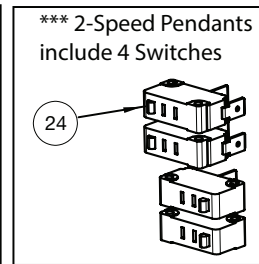
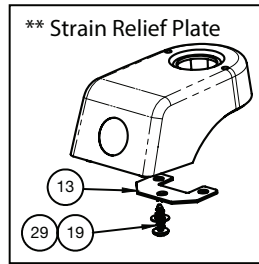

Part No.	Ref No.	Description	Qty.
Ecur-0001		Strain Relief Kit	1
	23	Strain Relief	1
	3	Strain Relief Collar	1
	20	Screw M4 X 1.79 x 33.5 Thd Roll Plstc	2
	29	Washer M4 Lk Stt	2
	28	Washer M4 x 8mm Od Sst	2
Ecur-0010	-	Instruction Sheet	1
		Switch Repair Kit, 2 Speed, 4 Switch	1
	7	Switch Gasket	1
	10	Switch Housing	1
	12	Pin Hinge	1
	14	Retainer Plate	1
	17	Screw M3 X 1.34 x 16mm Lg Thd Roll Plstc	2

Part No.	Ref No.	Description	Qty.
	18	Screw M3 x 1.34 x 35mm Lg Thd Roll Plstc	4
	24	Pendant Switch	4
	25	Rocker Plate	1
	27	Washer M3 x 6mm OD Sst	2
	-	Instruction Sheet	1
ECUR-0011		Switch Repair Kit, 1 Speed, 2 Switch	1
	7	Switch Gasket	1
	10	Switch Housing	1
	12	Pin Hinge	1
	14	Retainer Plate	1
	17	Screw M3 X 1.34 X 16Mm Lg Thd Roll Plstc	2
	18	Screw M3 X 1.34 X 35Mm Lg Thd Roll Plstc	4
	24	Pendant Switch	2
	25	Rocker Plate	1
	27	Washer M3 X 6mm Od Sst	2
	-	Instruction Sheet	1
ECUR-0020		Enclosure Repair Kit, No E-Stop	1
	3	Strain Relief Collar	1
	4	Pendant Enclosure Back	1
	5	Pendant Enclosure Front	1
	6	Pendant Enclosure Top, No E-Stop	1
	N/S	Cord Gasket	1
		Enclosure Hardware Kit	1
	13	Strain Relief Plate	1
	16	Screw M3 x 1.34 x 12mm Lg Thd Roll Plstc	4
	19	Screw M4 x 1.79 x 12mm Lg Thd Roll Plstc	1
	18	Screw M4 x 1.79 X 33.5mm Lg Thd Roll Plstc	2
	23	Strain Relief	1
	27	Washer M3 x 6mm Od Sst	4
	29	Washer M4 Lk Sst	2
	28	Washer M4 x 8mm Od Sst	3
	-	Instruction Sheet	1
ECUR-0021		Enclosure Repair Kit, With E-Stop	1
	3	Coller Strain Relief Ergo Pendant	1
	4	Enclosure Pendant Ergo Back	1
	5	Enclosure Pendnat Ergo Front	1
	6	Enclosure Pendnat Ergo Top	1
		Gasket Silicone Cord Ergo Pendant	1
		Hardware Kit Enclosure Ergo Pndnt	1
	13	Plate Strain Relief Ergo	1
	16	Screw M3 x 1.34 x 12mm Lg Thd Roll Plstc	4
	19	Screw M4 x 1.79 x 12mm Lg Thd Roll Plstc	1
	18	Screw M4 x 1.79 x 33.5mm Lg Thd Roll Plstc	2
	23	Strain Relief	1
	27	Washer M3 x 6Mm Od Sst	4
	29	Washer M4 Lk Sst	2
	28	Washer M4 x 8mm Od Sst	3
	-	Instruction Sheet	1
ECUR-0030		Pendant Label Kit	1
	N/S	Instruction Sheet	1
	N/S	Logo Sticker Sheet	1
62809	N/S	Cord Warning Tag	1
23608124	24	Emergency Stop Push Button	1
23608110	2	Cable Bushing	1

FIGURE 21 – LIMIT SWITCH ASSEMBLY

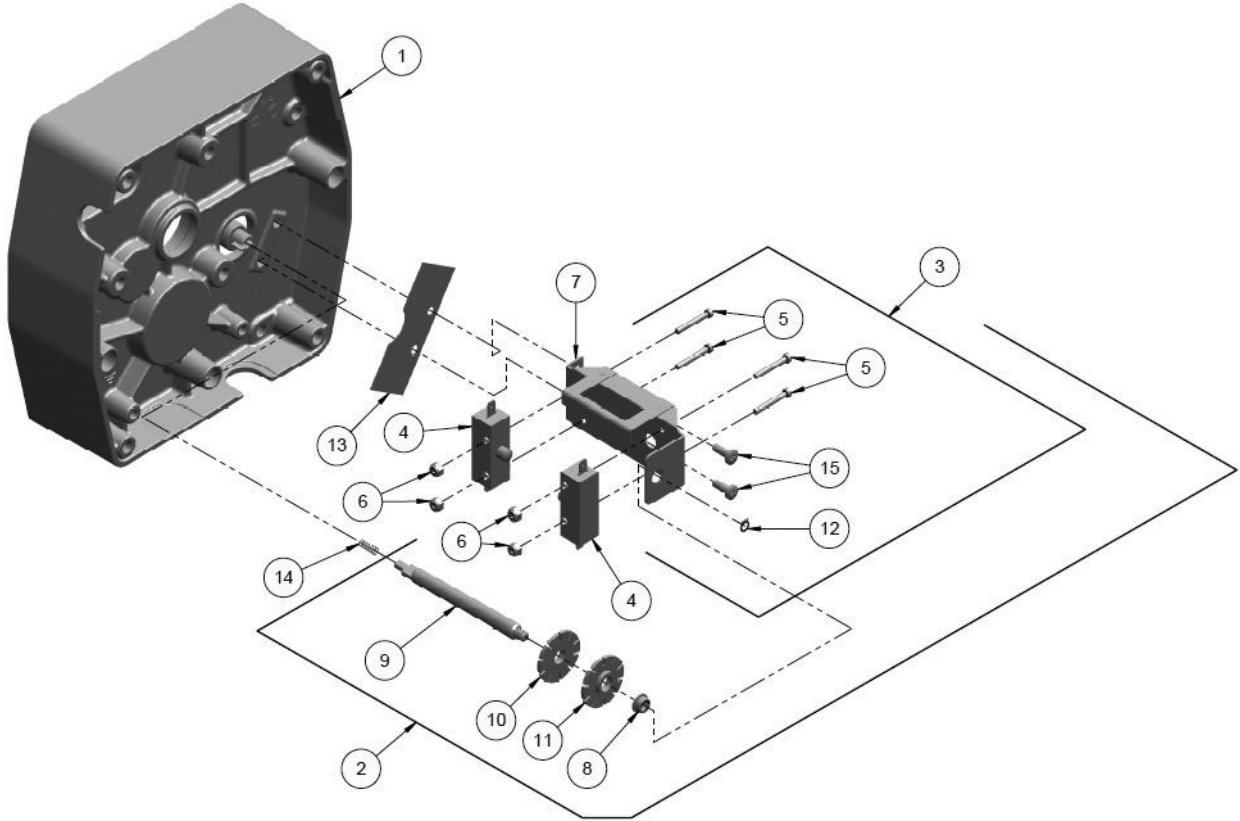

Parts List for Limit Switch Assembly

Ref. no	Description	Part No.	Qty
1	Transmission Cover	JM34-2	1
2	Limit Switch Assembly (Includes items 4-12)	918JG4	1
3	Limit Switch Bracket Assembly (Includes items 4-8)	918JG3	1
4	Switch	815J1	2
5	6-32UNC X 1" Screw	H1402P	4
6	6-32UNC Elastic Locknut	H3944	4
7	Limit Switch Bracket & Guide Assembly (Includes Item 8)	JF900-3	1

Ref. no	Description	Part No.	Qty
8	Bushing	JF531-4	1
9	Limit Switch Shaft	JF117-3S	1
10	Limit Switch Nut (silver)	SK6000-63Z	1
11	Limit Switch Nut (gold)	SK6000-63W	1
12	Retaining Ring	H5520	1
13	Insulator	JF754	1
14	Spring	JF343-3	1
15	10-24UNC x 1/2" Screw	H2970	2

FIGURE 22 – LONG LIFT LIMIT SWITCH PARTS

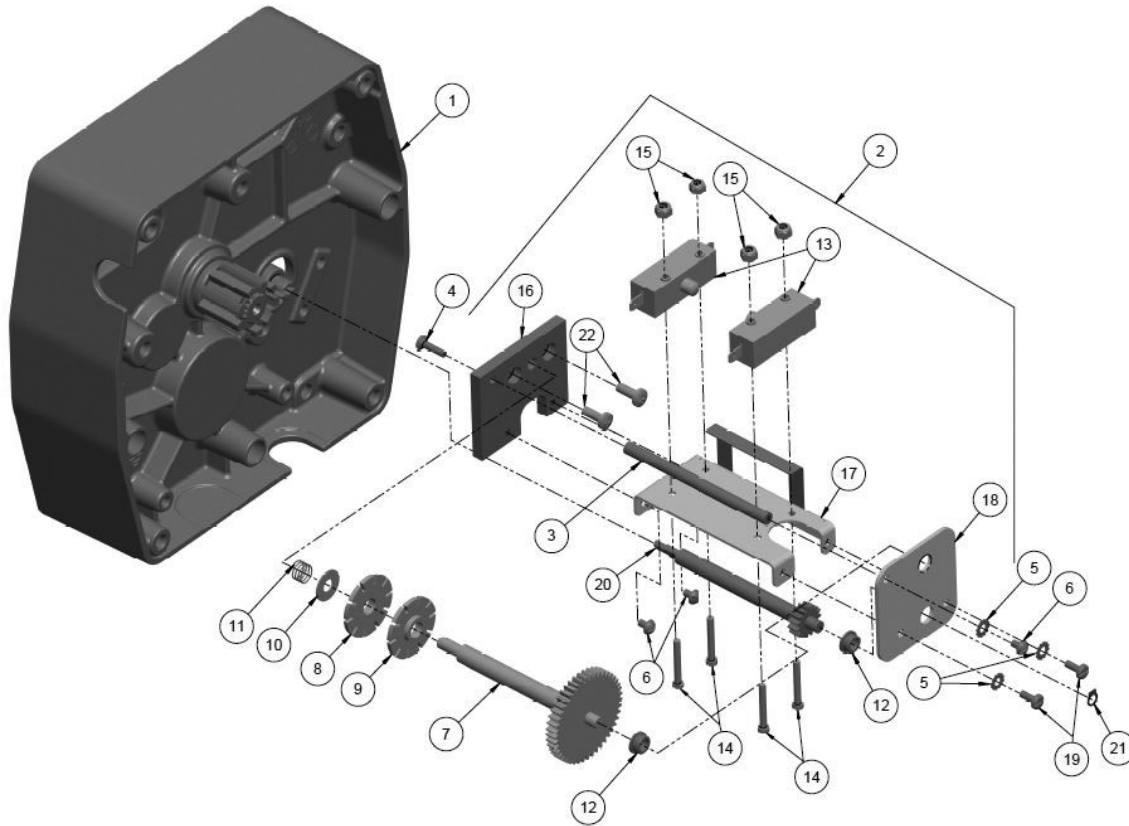

Parts List for Long Lift Limit Switch Parts

Ref. no	Description	Part No.	Qty
1	Transmission Cover	JM34-2	1
2	Limit Switch Assembly (Includes items 3-21)	944JG6	1
3	Post	110J14	1
4	8-32UNC X 1/2" Screw	H1210	1
5	#8 External-tooth Lockwasher	H4158	3
6	8-32UNC X 1/4" Screw	854823	3
7	Limit Switch Shaft & Gear	117JG2	1
8	Limit Switch Nut (gold)	SK6000-63W	1
9	Limit Switch Nut (silver)	SK6000-63Z	1
10	Thrust Washer	255K16	1
11	Spring	PB287	1
12	Bushing	JF531-4	2

Ref. no	Description	Part No.	Qty
13	Switch	815J1	2
14	6-32UNC X 1" Screw	H1402P	4
15	6-32UNC Elastic Locknut	H3944	4
16	Mounting Plate	129J1	1
17	Frame and Guide Assembly	258JG7	1
18	End Plate	258J8	1
19	8-32UNC X 3/8" Screw	H2741P	2
20	Drive Pinion	427J1	1
21	Retaining Ring	H5520	1
22	10-24UNC X 3/8" Screw	H2981P	2

FIGURE 23 – TRANSMISSION

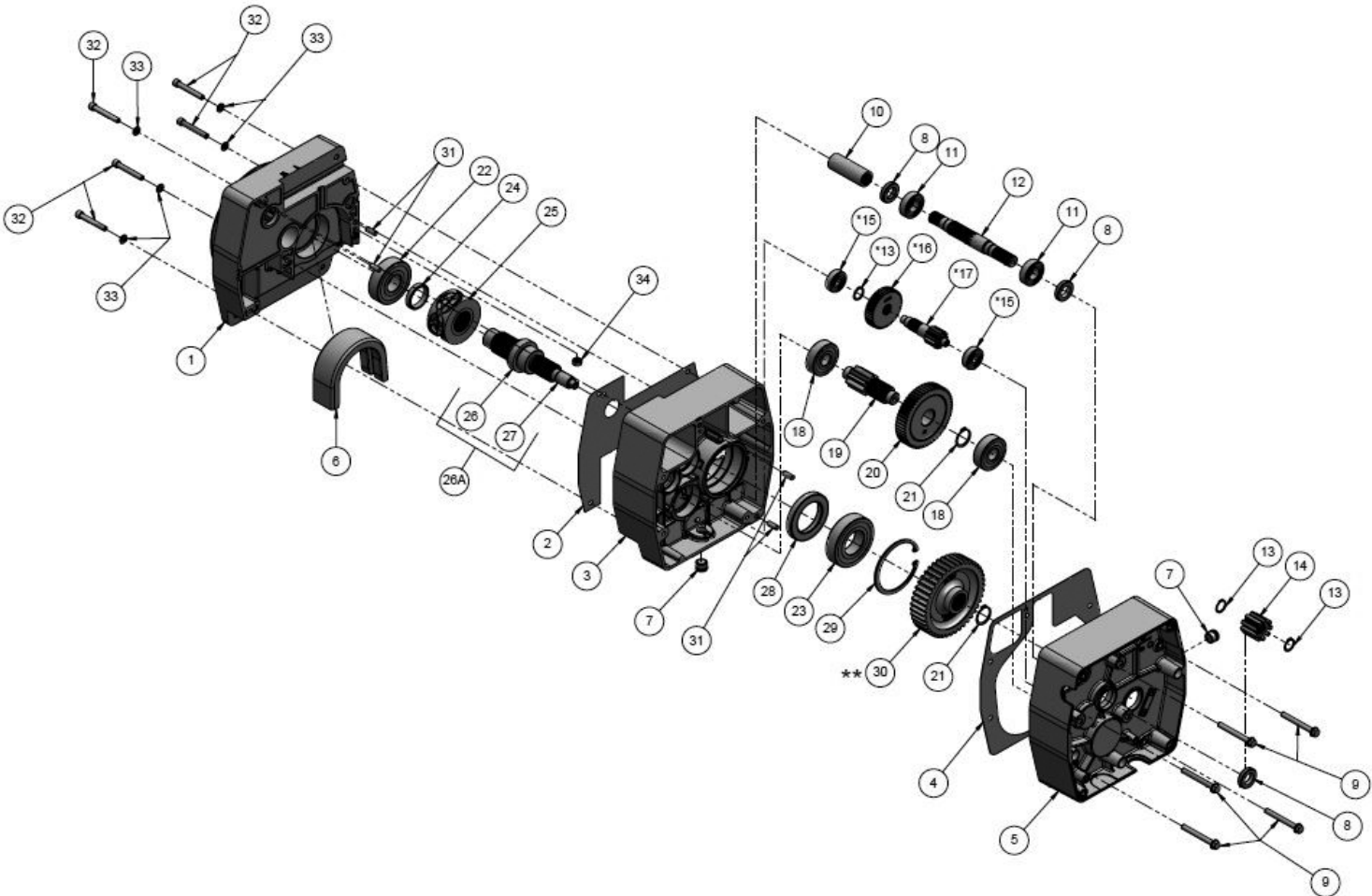

FIGURE 23 – TRANSMISSION CONTINUED

Parts List for Transmission

Ref. no	Description	Part No.	Qty
1	Sheave Housing	JM33-1	1
2	Sheave Housing Gasket	JM560-3	1
3	Transmission Housing	JM35-1	1
4	Transmission Housing Gasket	JM560-2	1
5	Transmission Cover	JM34-2	1
6	Chain Guide	JM273	1
7	Oil Plug - Drain/Fill	H6297	2
8	Oil Seal	561K2	3
9	Screw Hex Washer Head Self-threading	H2693P	5
10	Motor Coupling	JM107	1
11	Bearing	500K33	2
12	Input Pinion 8 & 16 fpm	JL400C	1
12	Input Pinion 32 fpm	JL400-1A	1
13	Retaining Ring	H5501	3
14	Brake Hub Adapter	JL142	1
15	Bearing for 8 & 16 fpm	500K34	2
16	High Speed Gear for 8 & 16 fpm	JL426A	1
17	Intermediate Pinion 1/4 & 1/2 ton, 16 fpm	JL402B	1
17	Intermediate Pinion 1 & 2 ton	JL403B	1
18	Bearing	500K39	2
19	Output Pinion	JL401A	1
20	Overload Clutch Assembly 1/8 ton, 32 fpm	591JG22A	1
20	Overload Clutch Assembly 1/4 ton, 16 fpm	591JG25A	1
20	Overload Clutch Assembly 1/4 ton, 32 fpm	591JG22A	1
20	Overload Clutch Assembly 1/2 ton, 16 fpm	591JG16A	1
20	Overload Clutch Assembly 1/2 ton, 32 fpm	591JG21A	1
20	Overload Clutch Assembly 1 & 2 ton	591JG17A	1
21	Retaining Ring	H5503	1
22	Bearing	500K28	1
23	Bearing	500K40	1
24	Spacer-Load Sheave	JM127	1
25	Load Sheave - 9/32" Dia Chain	JF16-3	1
26A	Load Sheave Shaft Assembly (Item 26 & 27)	132JM1	1
26	Load Sheave Shaft	JM132	1
27	Stub Shaft - Limit Switch Drive	JM140	1
28	Oil Seal	011612800	1
29	Retaining Ring	H5598	1
30	Output Gear	JL421A	1
31	Dowel Pin	H5382	4
32	Socket Head Cap Screw 1/4" Dia.	S49-10	5
33	Lock Washer, Medium 1/4" Dia.	H4084P	5
34	1/4 - 20 UNC Lock Nut (Flexlock Nut Brand Only)	H3942P	1
*	Oil		1 qt.

FIGURE 24 – CHAINING PARTS

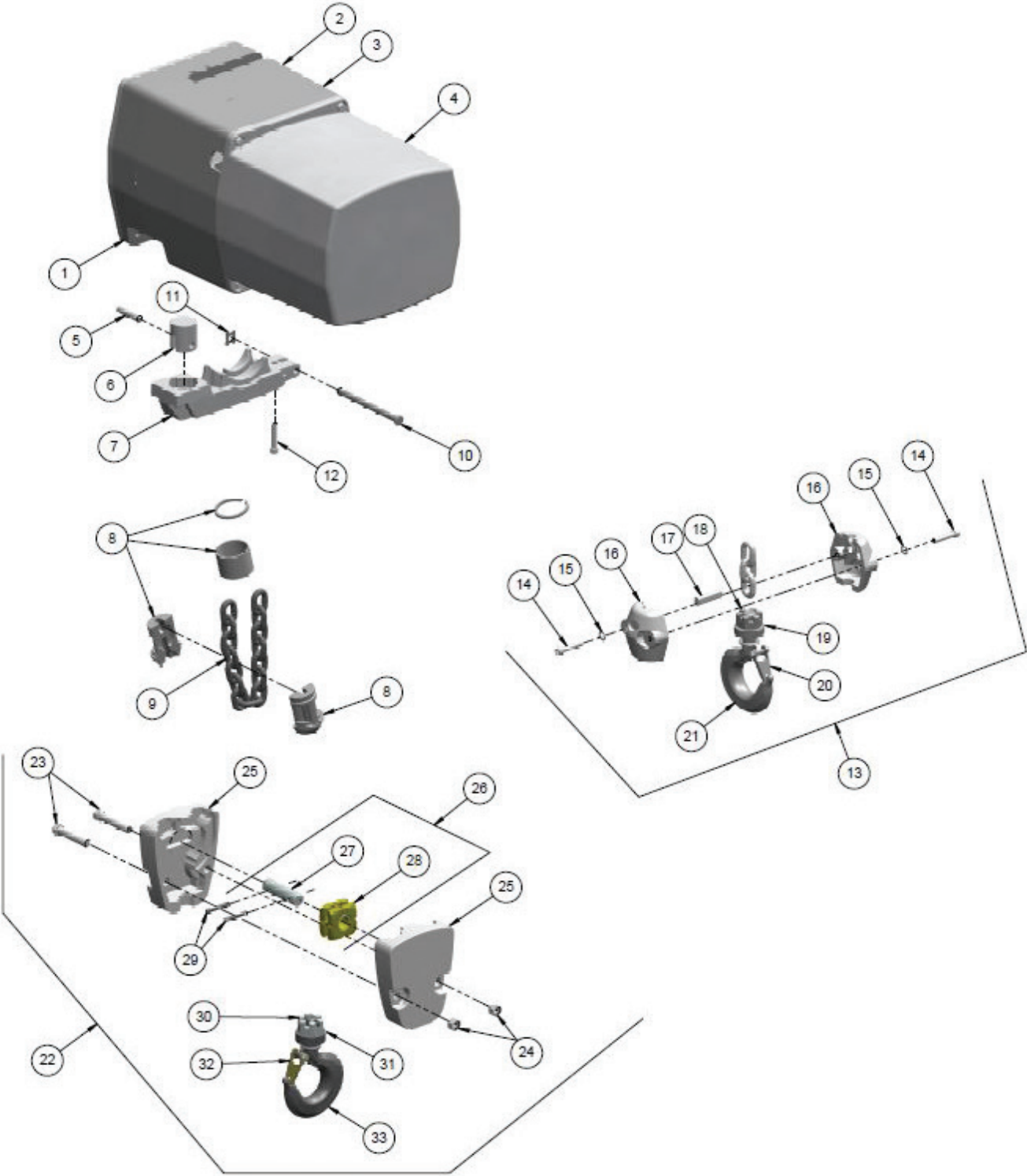

FIGURE 24 — CHAINING PARTS CONTINUED

Parts List for Chaining Parts

Ref. no	Description	Part No.	Qty
1	Sheave Housing	JM33-1	1
2	Transmission Housing	JM35-1	1
3	Transmission Cover	JM34-2	1
4	Electrical Cover	JM36	1
5	Chain Support Pin (2 ton only)	JM111	1
6	Chain Support (2 ton only)	JM109	1
7	Chain Stripper	JM254	1
8	Chain Stop Kit (Kits include halves, sleeve and retaining ring)	75JG6K	1
9	Load Chain	JL19-1	*
10	Attachment Pin	JM18-3	1
11	Retaining Clip	H5597	1
12	1/4-20UNC x 1 1/4" Socket Head Cap Screw	S49-77	1
13	Bottom Block Assembly 1 ton & Under	913JG3AS	1
14	1/4-20UNC x 1 1/4" Socket Head Cap Screw	S49-77	2
15	1/4" Internal-tooth Lockwasher	H4134	2
16	Load Block Frame	30J14	2
17	Load Block Pin	18J8	1
18	Slotted Hex Nut	H3986P	1
19	Bearing	JF510	1
20	Latch Kit	4X1304	1
21	Bottom Hook Assembly with Latch for 1 Ton & Under	3JG20S	1
22	Bottom Block Assembly for 2 Ton	JF914-6	1
23	3/8-24 Hex Locknut	H3964P	2
24	Load Block Screw	H2403P	2
25	Load Block Frame	JF30-1	2
26	Sheave Shaft Assembly	JF917-1	1
27	Sheave Shaft	JF122-1	1
28	Idler Sheave & Bearing Assembly	JF916	1
29	Roll Pin	H5234	2
30	3/8-24 Hex Locknut	H3991P	1
31	Bearing	JF511	1
32	Latch Kit	4X1305	1
33	Bottom Hook Assembly with Latch for 2 Ton	3KG1W	1

* Replacement chain is sold by the foot. For single-chained models, add 2 ft to the lift for the total amount of feet. For double-chained models, double the lift and add 3 ft.

NOTES

Lined area for notes, consisting of multiple horizontal lines.

WARRANTY

LIMITATION OF WARRANTIES, REMEDIES AND DAMAGES

INDEMNIFICATION AND SAFE OPERATION

Buyer shall comply with and require its employees to comply with directions set forth in instructions and manuals furnished by Seller and shall use and require its employees to follow such instructions and manuals and to use reasonable care in the use and maintenance of the Goods and any Replacement Parts. Buyer shall not remove or permit anyone to remove any warning or instruction signs on the Goods or Replacement Parts. In the event of personal injury or damage to property or business arising from the use of the Goods or Replacement Parts, Buyer shall within 48 hours thereafter give Seller written notice of such injury or damage. Buyer shall cooperate with Seller in investigating any such injury or damage and in the defense of any claims arising therefrom.

If Buyer fails to comply with this section or if any injury or damage is caused, in whole or in part, by Buyer's failure to comply with applicable federal or state laws, rules or regulations safety requirements, Buyer shall indemnify and hold Seller harmless against any claims, loss or expense for injury or damage arising from the use of the Goods and/or Replacement Parts.

CMCO Warranty (HOISTS)

A. Columbus McKinnon Corporation ("Seller") warrants to the original end user ("Buyer") that: (a) for a period of one (1) year from the date of Seller's delivery of the goods (collectively, the "Goods") to the carrier, the electrical components of the Goods will be free from defects in workmanship and materials; and (b) for the life of the Goods, the mechanical components of the Goods will be free from defects in workmanship and materials. In addition, Seller warrants to Buyer that, for a period of one (1) year from the date of their delivery by Seller to the carrier, any aftermarket or replacement parts, accessories or components purchased by Buyer with respect to any Goods (collectively, "Replacement Parts") will be free from defects in workmanship and materials.

B. IN THE EVENT OF ANY BREACH OF ANY SUCH WARRANTY, SELLER'S SOLE OBLIGATION SHALL BE EXCLUSIVELY LIMITED TO, AT THE OPTION OF SELLER, REPAIR OR REPLACEMENT, F.O.B. SELLER'S POINT OF SHIPMENT, OF ANY GOODS OR REPLACEMENT PARTS THAT SELLER DETERMINES TO HAVE BEEN DEFECTIVE OR, IF SELLER DETERMINES THAT SUCH REPAIR OR REPLACEMENT IS NOT FEASIBLE, TO A REFUND OF THE PURCHASE PRICE UPON RETURN OF THE GOODS OR REPLACEMENT PARTS TO SELLER. NO CLAIM AGAINST SELLER FOR ANY BREACH OF (i) SUCH WARRANTY WITH RESPECT TO THE ELECTRICAL COMPONENTS OF ANY GOOD, OR ANY REPLACEMENT PART, SHALL BE VALID OR ENFORCEABLE UNLESS BUYER'S WRITTEN NOTICE THEREOF IS RECEIVED BY SELLER WITHIN ONE (1) YEAR FROM THE DATE OF SELLER'S DELIVERY TO THE CARRIER AND (ii) SUCH WARRANTY WITH RESPECT TO THE MECHANICAL COMPONENTS OF ANY GOOD SHALL BE VALID OR ENFORCEABLE UNLESS BUYER'S WRITTEN NOTICE THEREOF IS RECEIVED BY SELLER WITHIN ONE (1) YEAR FROM THE DATE THE DATE ANY ALLEGED CLAIM ACCRUES. EXCEPT FOR THE WARRANTIES SET FORTH ABOVE, SELLER MAKES NO OTHER WARRANTIES WITH RESPECT TO THE GOODS OR ANY REPLACEMENT PART, WHETHER EXPRESSED OR IMPLIED, INCLUDING ANY WARRANTIES OF MERCHANTABILITY, FITNESS FOR A PARTICULAR PURPOSE, QUALITY AND/OR THOSE ARISING BY STATUTE OR OTHERWISE BY LAW OR FROM ANY COURSE OF DEALING OR USE OF TRADE, ALL OF WHICH ARE HEREBY EXPRESSLY DISCLAIMED.

C. IN NO EVENT SHALL SELLER BE LIABLE TO BUYER OR ANY THIRD PARTY WITH RESPECT TO ANY GOOD OR REPLACEMENT PART, WHETHER IN CONTRACT, TORT OR OTHER THEORY OF LAW, FOR LOSS OF PROFITS OR LOSS OF USE, OR FOR ANY INCIDENTAL, CONSEQUENTIAL, SPECIAL, DIRECT OR INDIRECT DAMAGES, HOWSOEVER CAUSED. SELLER'S MAXIMUM LIABILITY TO BUYER WITH RESPECT TO THE GOODS OR ANY REPLACEMENT PART SHALL IN NO EVENT EXCEED THE PRICE PAID BY BUYER FOR THE GOODS OR REPLACEMENT PART THAT ARE THE SUBJECT OF THE APPLICABLE CLAIM.

D. Seller shall not be liable for any damage, injury or loss arising out of the use of the Goods or any Replacement Part if, prior to such damage, injury or loss, such Goods or Replacement Parts are: (1) damaged or misused following Seller's delivery to the carrier; (2) not maintained, inspected, or used in compliance with applicable law and Seller's written instructions and recommendations; or (3) installed, repaired, altered or modified (a) with any part or accessory other than those supplied by Seller or (b) without compliance with such laws, instructions or recommendations.

E. This warranty is limited and provided only to the original end user. **Each Good and Replacement Part must be registered within sixty (60) days of receipt of each product to establish eligibility.** Please register at www.cmworks.com/hoist-warranty-registration or submit registration card via US mail.

F. Any action against Seller for breach of warranty, negligence or otherwise in connection with the electrical components of any Good must be commenced by Buyer within one (1) year after: (a) the date any alleged claim accrues; or (b) the date of delivery of the Goods to Buyer, whichever is earlier. Any action against Seller for breach of warranty, negligence or otherwise in connection with the mechanical components of any Good must be commenced by Buyer within one (1) year after the date any alleged claim accrues. Any action against Seller for breach of warranty, negligence or otherwise in connection with any Replacement Part must be commenced by Buyer within one (1) year after: (y) the date any alleged claim accrues; or (z) the date of delivery of the Replacement Part to Buyer, whichever is earlier.

G. This warranty is contingent upon Buyer's proper maintenance and care of the Goods and/or Replacement Parts, and does not extend to normal wear and tear. Seller reserves the right, at its option, to void this warranty in the event of Buyer's use with the Goods and/or Replacement Parts of parts or accessories other than those supplied by Seller

WARNING

Alterations or modifications of equipment and use of non-Seller replacement parts can lead to dangerous operation and injury.

TO AVOID INJURY:

- Do not alter or modify equipment.
- Do use only factory replacement parts manufactured by Seller.



COLUMBUS MCKINNON
CORPORATION

FAMILY OF BRANDS



USA: Ph: (800) 888.0985 • (716) 689.5400 • Fax: (716) 689.5644 • www.cmworks.com

CANADA: Ph: (877) 264.6478 • Fax: (877) 264.6477 • www.cmworks.com